

# FILTERS

---

## CATALOG







● **First class facilities**  
high level of automation  
with in-line process control

● **Know-how**  
from the design to the production  
of the finished product

● **Full product range**  
standard, customized, ex-proof,  
stainless steel, safety certified

● **Advanced technology**  
thanks to long lasting  
investments in R&D

● **Quality first**  
according to ISO 9001, including  
automotive sector methods

● **Sales & service**  
worldwide network of experienced  
engineers, oriented to customer care

● **Professional team**  
to quickly meet every  
customer need





# INDEX

## FILTERS

		Table	Pag			
<b>GENERAL INFORMATION</b>						
Fluid contamination		LF010	5			
Filtration guidelines		LF020	9			
<b>IN LINE FILTERS</b>						
		Qmax [l/min]	Pmax [bar]	ports size		
FPS	BSPP or SAE J1926-1 threaded ports	440	420	1/2" ÷ 1 1/2"	LF032	15
FPH	SAE 6000 flanged ports	400	420	3/4" ÷ 1 1/2"	LF040	27
<b>RETURN LINE FILTERS</b>						
FRS	tank-top, BSPP or SAE J1926-1 threaded ports	600	8	1/2" ÷ 2"	LF050	37
<b>SUCTION FILTERS</b>						
FSS	BSPP threaded ports	450		1/2" ÷ 3"	LF060	49



# Fluid contamination

**Fluid contamination** defines the presence of foreign particles and substances into the hydraulic fluid, classified in 3 families (solid, water and air contamination), which produce different effects on hydraulic components. This aspect is a main issue for all hydraulic systems, being responsible for failures and increased machine downtime with consequent heavy costs for end users.

**The purpose of this document is to provide general information about type, sources and effects of fluid contamination on hydraulic components.**

**In particular it is focused on the solid contamination, most commonly present in hydraulic systems, with a description of international methods for its measurement and classification.**

## 1 SOLID CONTAMINATION

It is responsible for wearing and damages of hydraulic components causing approximately 80% of hydraulic systems failures.

Solid contaminants can enter into the hydraulic system from the external environment or they can be generated during the system operation. A detailed analysis about the potential causes of fluid contamination is described in section 4

**Effects:** solid contamination causes accelerated wear and sticking phenomena, with consequent increased internal leakages and inaccurate regulation of hydraulic components. In the worst cases it may lead to the components breakage.

A detailed analysis of the effects of solid contamination on hydraulic components is described in section 5

**Removal methods:** the solid contamination cannot be completely removed but it can be consistently reduced at acceptable levels by means of **hydraulic filters (in line and return line type)**.

Contamination coming from external environment can be also prevented using specific air filters and pressurized tanks.

**An extensive description of filter types, contamination classes and suggested filtration circuits is described in the technical table LF020**

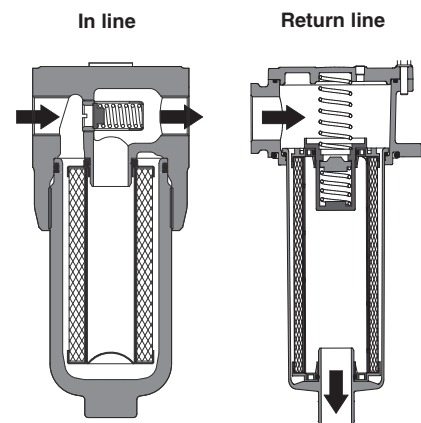

## 2 WATER CONTAMINATION

Water can be present into the hydraulic fluid as dissolved water (emulsion) or free water, depending to its concentration and fluid temperature.

Water can enter into the hydraulic system during oil filling operations, through the tank cover or by the air moisture present in the ambient.

**Effects:** water contamination causes oxidation and corrosion of metal parts, plus alteration of chemical proprieties of the hydraulic fluid.

**Removal methods:** sealed tanks are normally used in case of system out-doors installation to prevent water dropping.

Centrifugal separators are a valid solution to remove the water emulsion from the hydraulic fluid.

Breather filters are normally used to remove the humidity form the air entering the oil tank.

**Note:** consult Atos Technical Office for detailed information about water contamination removal

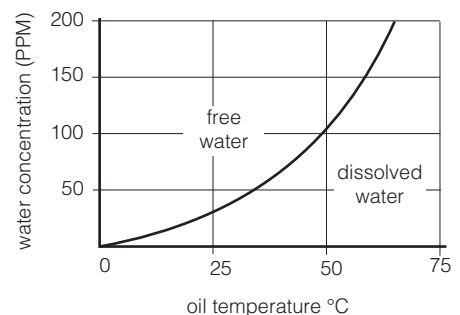

## 3 AIR CONTAMINATION

Air is always present into the hydraulic system before its commissioning, or it can be introduced during maintenance.

**Effects:** the presence of air may cause pumps damage due to cavitation, inaccurate valve regulation and vibrations.

**Removal methods:** air bleeding points are normally present in the upper side of the hydraulic system and in hydraulic components. The complete air bleeding procedure must be performed at the system commissioning of after maintenance operations.

**Note:** consult Atos Technical Office for detailed information about air bleeding procedures. See also [www.atos.com](http://www.atos.com), tech. table P002 for system commissioning

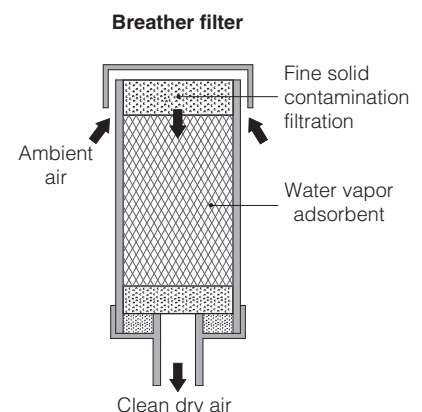

#### 4 SOURCES OF SOLID CONTAMINATION

The solid contamination has two main sources:

- **Fluid original contamination**, caused by poor quality hydraulic fluids, or fluids stored in dirty tanks
- **System progressive contamination**, generated during the system working and caused by wearing of metal parts and rubber pipes

In a more detailed analysis, following causes of contamination can be identified:

##### 4.1 First fluid filling

Oil coming from shipping containers usually has a contamination level higher than the standards acceptable for most hydraulic systems: oil cannot be assumed to be clean unless it has been carefully filtered.

##### 4.2 Built-in contamination

Different contaminants can be found in new systems and they can be directly related to manufacturing and assembling operations.

##### 4.3 Self-generated contamination

The major source of contamination directly comes from the normal hydraulic system operation. Most of contaminant are due to rubber released from the inner walls of flexible hoses, some from with moving parts of hydraulic components, like pumps and valves

##### 4.4 External contamination

Contaminants coming from the surrounding environment can enter the hydraulic fluid through reservoir breather caps and worn cylinder rod seals.

##### 4.5 Maintenance-induced contamination

Contaminants coming from the surrounding environment can enter the system during maintenance operations. Inaccurate cleaning of the pipes after the replacement of failed components can be the source of further contamination.

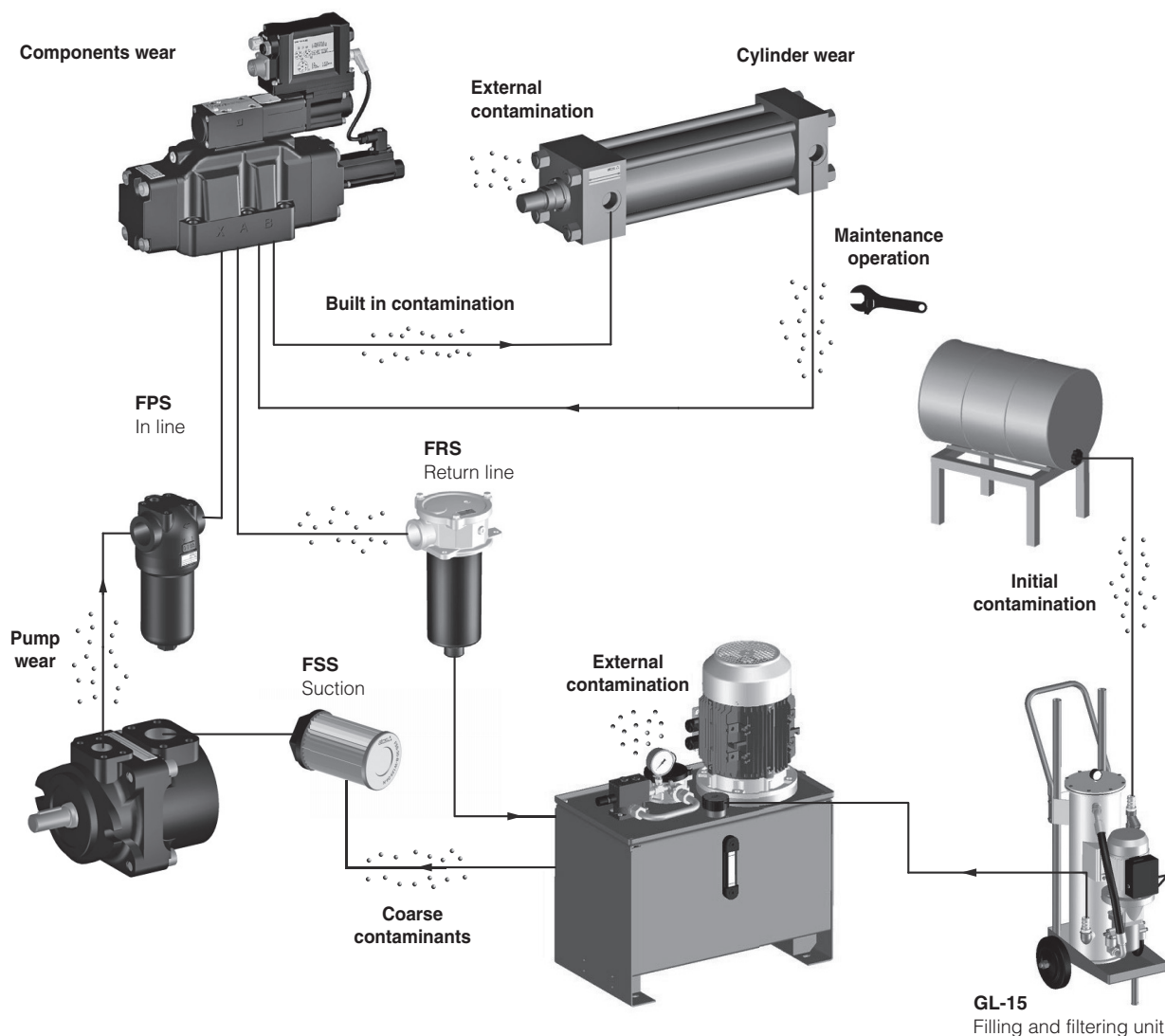



## 5 EFFECTS OF SOLID CONTAMINATION

The presence of solid contaminants into the hydraulic fluid have harmful effects on the correct operation and service life of hydraulic components as pumps, valves and actuators.

They mainly cause abrasion, erosion and fatigue effects on components surface with following main consequences:

- increased internal leakages
- sticking effects
- permanent wear of moving parts

Typical failures produced by solid contamination can be classified as:

- **Transitory failures**, when particles enter components causing its temporarily malfunction. The components returns to correctly operate as soon the particles are removed by the oil flow.
- **Progressive deterioration**, when particles cause micro-erosion and abrasion of the component surfaces. This failure causes a progressive degradation of performances until the functionality of the component is definitively compromised.
- **Irreparable failure**, when particles enter the gap between mobile parts causing the sudden sticking. This failure could be solved by cleaning the internal parts of the component, in the worst cases the whole components must be replaced

### Typical failures in spool valve

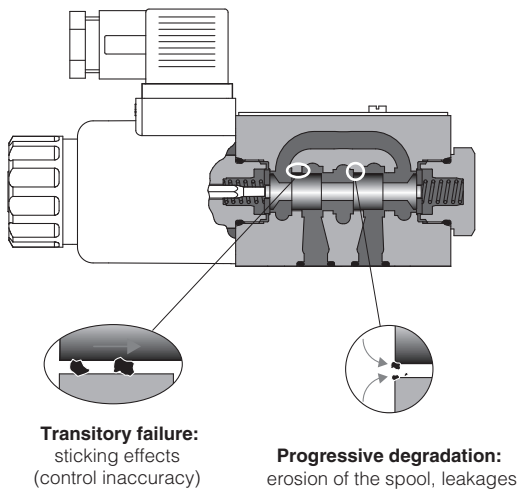

### Typical failures in poppet cartridges

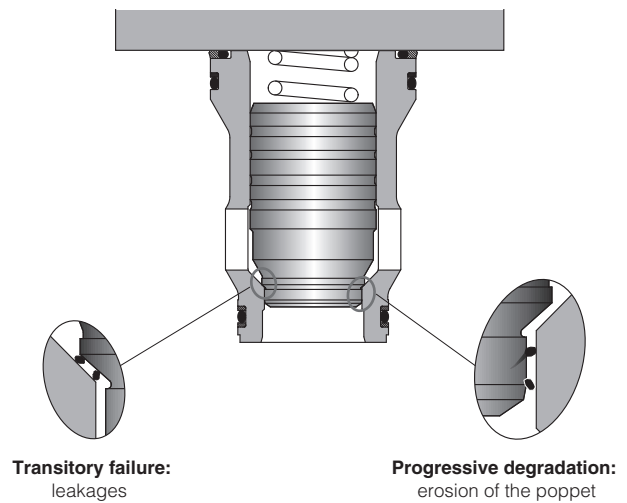

### Typical failures in cylinders

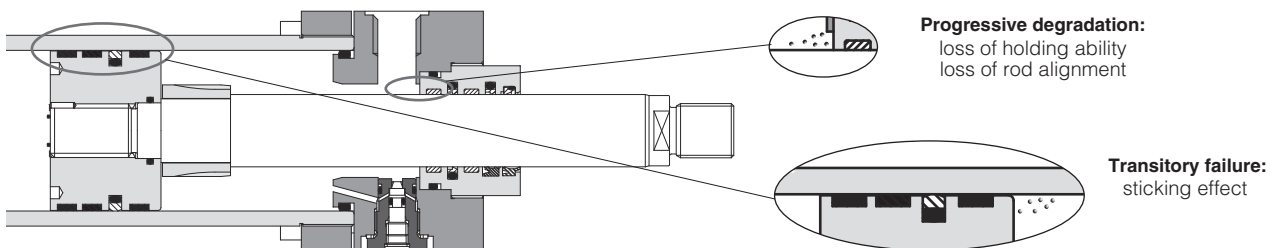

## 6 MEASUREMENT OF SOLID CONTAMINATION

One of the most common methods used by the industry for solid contamination analysis is the Automatic Particles Counter (APC). It is based on the principle of a light beam projected through the sample of fluid to be analyzed.

As a solid particle passes through the light beam, it results in a measurable energy drop that is proportional to the size of the particle.

This method permits to measure the quantity and dimensions of solid particles present in the fluid and it is used for the classification of the fluid contamination level, as described in section 5

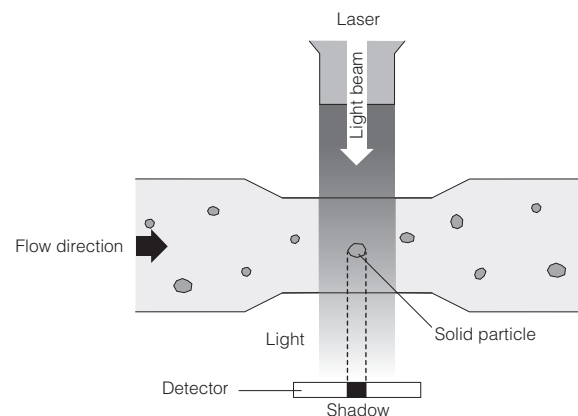

## 7 CLASSIFICATION OF CONTAMINATION LEVEL

The contamination level identifies the quantity and dimensions of solid particles present into the hydraulic fluid. It is classified according to the European standard ISO 4406/1999, while for North America it is classified by SAE AS 4059 or NAS 1638 standards.

### 7.1 ISO 4406 classification

ISO 4406 is the European standard being used extensively within the industrial hydraulics to measure and classify the fluid contamination. The contamination level is measured by counting the number of particles of a certain dimension present into a 100 ml of fluid. It is expressed by a combination of 3 codes, i.e: **20 / 18 / 15**, respectively identifying the quantity of contaminants with dimension  $> 4 \mu\text{m}_{(c)}$ ,  $> 6 \mu\text{m}_{(c)}$  and  $> 14 \mu\text{m}_{(c)}$ , as per following table

ISO CODE (to ISO 4406)	Particle quantity / 100 ml	
	from	to
5	16	32
6	32	64
7	64	130
8	130	250
9	250	500
10	500	1.000
11	1.000	2.000
12	2.000	4.000
13	4.000	8.000
14	8.000	16.000
15	16.000	32.000
16	32.000	64.000
17	64.000	130.000
18	130.000	260.000
19	260.000	500.000
20	500.000	1.000.000
21	1.000.000	2.000.000
22	2.000.000	4.000.000
23	4.000.000	8.000.000
24	8.000.000	16.000.000
25	16.000.000	32.000.000
26	32.000.000	64.000.000
27	64.000.000	130.000.000
28	130.000.000	250.000.000

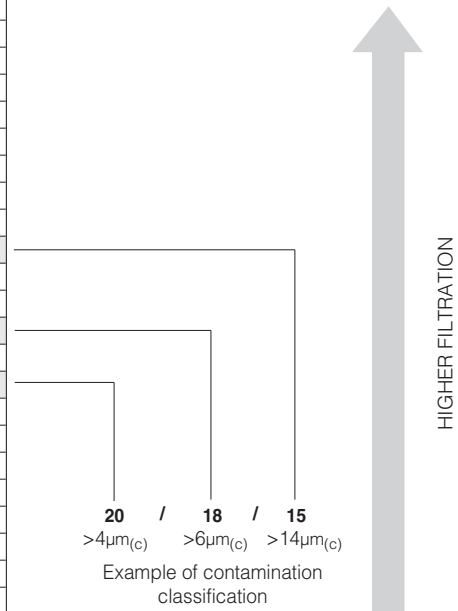

### 7.2 SAE AS 4059 classification

This classification is normally adopted in North America, particularly in aerospace industry. The contamination level is classified by a combination of 3 codes, i.e. **7B/6C/5D** identifying the quantity of contaminants of a certain dimension present into 100 ml of fluid

Dimensions code		A	B	C	D	E	F
Particle dimensions		$> 4 \mu\text{m}_{(c)}$	$> 6 \mu\text{m}_{(c)}$	$> 14 \mu\text{m}_{(c)}$	$> 21 \mu\text{m}_{(c)}$	$> 38 \mu\text{m}_{(c)}$	$> 70 \mu\text{m}_{(c)}$
		Particle quantity /100 ml					
Contamination classes	000	195	76	14	3	1	0
	00	390	152	27	5	1	0
	0	780	304	54	10	2	0
	1	1.560	609	109	20	4	1
	2	3.120	1.220	217	39	7	1
	3	6.250	2.430	432	76	13	2
	4	12.500	4.860	864	152	26	4
	5	25.000	9.730	1.730	306	53	8
	6	50.000	19.500	3.460	612	106	16
	7	100.000	38.900	6.920	1.220	212	32
	8	200.000	77.900	13.900	2.450	424	64
	9	400.000	156.000	27.700	4.900	848	128
	10	800.000	311.000	55.400	9.800	1.700	256
11	1.600.000	623.000	111.000	19.600	3.390	1.020	
12	3.200.000	1.250.000	222.000	39.200	6.780		

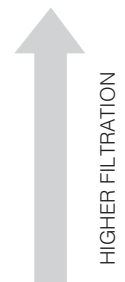

### 7.3 NAS 1638 classification

NAS 1638 (National Aerospace Standard) is a type of classification used in North America.

It divides the dimensional distribution of the particles into intervals (5-15  $\mu\text{m}$ , 15-25  $\mu\text{m}$ , etc.) and assigns a code to each interval, according to the following table in which is reported also a comparison with ISO 4406 and SAE AS 4059 standards.

ISO 4406	SAE AS 4059	NAS 1638
14/12/09	4A/3B/3C	3
15/13/10	5A/4B/4C	4
16/14/11	6A/5B/5C	5
17/15/12	7A/6B/6C	6
18/16/13	8A/7B/7C	7
19/17/14	9A/8B/8C	8
20/18/15	10A/9B/9C	9
21/19/16	11A/10B/10C	10
22/20/17	12A/11B/11C	11
23/21/18	13A/12B/12C	12



## Filtration guidelines

**Cleanliness of hydraulic fluid is a priority aspect in the design of all hydraulic systems as approximately 80% of failures are caused by the presence of solid contamination.**

The solid contamination cannot be completely removed, but it can be consistently reduced and controlled by means of hydraulic filters (in line and return line type, see section 2) so that the quantity and dimensions of particles present into the fluid (contamination class) are acceptable for the specific type of system.

**The purpose of this document is to provide information on the different types of filters and suggestions for their correct use. Through an optimized filtration system it is possible to obtain appropriate fluid cleanliness and thus reduce the damages caused by contamination, extending the life of the machines and preventing production downtime.**

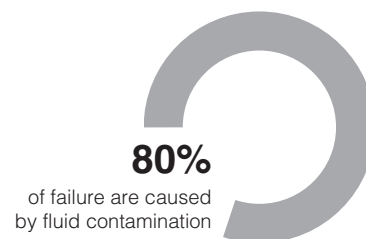

### 1 RECOMMENDED CONTAMINATION CLASSES

The **recommended fluid contamination class** is the max level of contamination acceptable for a certain hydraulic system and it depends to the filtration system architecture.

The fluid contamination class must be evaluated taking into account several parameters as:

- type of hydraulic components installed in the system: the required cleanliness level has to be determined according to the most sensitive component, i.e. presence of servoproportional valves
- type of application and surrounding environment: particular dusty environments , i.e. ceramic presses, require specific filtration circuits and methods to prevent that the solid contamination enters the system tank (pressurized tank)
- duty cycle: heavy duties and high pressure values require better contamination classes
- expected system lifetime
- typical operation and start-up temperatures

The fluid contamination level of a specific hydraulic system corresponds to the contaminant level measured in the tank.

The following table provides the suggested contamination classes, depending on the hydraulic components and their expected operating life. The contamination class has to be selected according to the most sensitive component installed in the system.

Standard	Typical contamination classes						
	15/13/10	16/14/11	17/15/12	18/16/13	19/17/14	20/18/15	21/19/16
ISO 4406	15/13/10	16/14/11	17/15/12	18/16/13	19/17/14	20/18/15	21/19/16
NAS 1638	4	5	6	7	8	9	10
SAE 5049	5A/4B/4C	6A/5B/5C	7A/6B/6C	8A/7B/7C	9A/8B/8C	10A/9B/9C	11A/10B/10C
Recommended filter element	F03	F03 F06	F06	F06 F10	F10 F20	F20 F25	
Component							
Proportional valves		longer life		normal operation			
Solenoid & conventional valves					longer life	normal operation	
Variable displacement pumps				longer life		normal operation	
Fixed displacement pumps					longer life		normal operation
Cylinders					longer life	normal operation	

## 2 HYDRAULIC FILTERS TYPE

The architecture of a filtration system involves the use of different type of hydraulic filters with specific characteristics; typically they are "in line" and "return line" filters.

The type of fluid used in the hydraulic system influences the choice of filter.

It is always recommended to verify the compatibility of the fluid characteristics with the selected filter.

### 2.1 In line filters

In line filters are normally installed in the system main line, immediately after the pump or before valve's manifold, in order to protect all downstream components from contamination.

They have to be sized in accordance with the maximum system pressure and flow rate.

Atos in line filters **FPS** (threaded ports) and **FPH** (SAE 6000 flanged ports) are suitable for max operating pressure up to 420 bar.

In line filters are provided with or without by-pass valve:

- filters with by-pass valve are used to permit the flow passage in case of clogged filtering element. This is an extreme condition to be always avoided by a correct maintenance
- filters without by-pass valves are used to protect critical components like servoproportional valves; in this execution the filter element can withstand a higher differential pressure (collapse pressure)

In line filters can be provided with a clogging indicator, notifying the status of the filter element and allowing its replacement before the filter by-pass opening (if present), see section 6.



FPS



FPH



FRS



FSS

### 2.2 Return line filters

They perform the **filtration of the fluid returning back to the tank from the hydraulic circuit**, ensuring that all the contaminants generated by components wear do not enter the tank and will not be recirculated into the system.

They have to be sized considering the maximum flow on return line during the whole machine cycle; particularly, in case of differential cylinders the return flow could be greater than the pump flow.

Return line filters can be installed in line or on the top of the hydraulic tank and have to be selected considering return line pressure.

Atos return line filters type **FRS** are designed for tank top mounting and to withstand max operating pressure up to 8 bar.

Return line filters are provided with a by-pass valve to prevent dangerous excessive back-pressure in the return line caused by the clogged filter element.

The filter outlet must be always located below the fluid level, in all operating conditions, to prevent possible foaming of the fluid in the tank.

### 2.3 Suction filters

These filters are used to **protect the pump from ingestion of coarse contamination**. Atos suction filters type **FSS** are designed to be directly fit on the pumps suction line.

To avoid the risk of pump cavitation, suction filters are generously sized, with high filtration ratings and low differential pressures.

Suction filters have to be sized also considering cold start-up operations, because low oil temperatures could boost up cavitation phenomenon.

Due to cavitation reasons they are normally avoided for variable displacement piston pumps.

## 3 FILTER EFFICIENCY AND BETA RATIO

The filter efficiency is the capability of the filter to block a certain quantity of particles equal or greater than a defined dimension.

The most commonly used rating in the industry is the **Beta ratio  $\beta_x(c)$** , defined as the number of particles of a given size upstream the filter, divided by the number of particles of the same size counted downstream the filter. The higher the Beta Ratio, the higher is the filter efficiency.

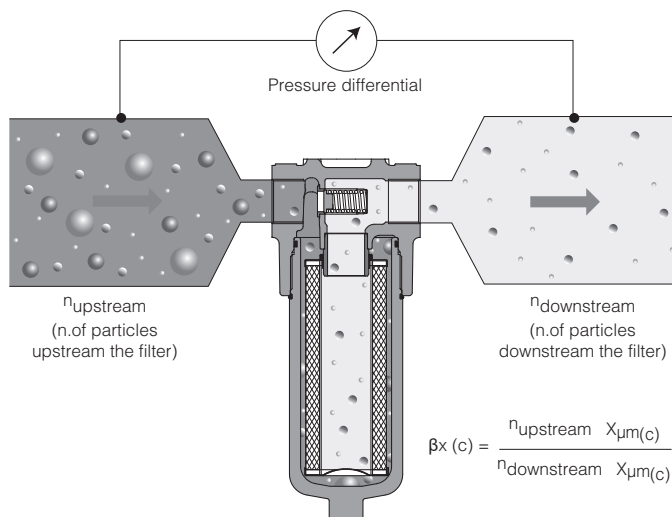

### 3.1 Standards for Beta ratio determination

Since 1999 the **ISO16889** has been introduced as international standard to regulate the execution of Multi-Pass Tests to assess the Beta value of a filter element, replacing old ISO 4578.

ISO16889 considers the filter efficiency = 99,9% ( $\beta$  ratio > 1000), while for old ISO4572 the efficiency was lower = 99,5% ( $\beta$ ratio > 200),

To avoid misunderstandings, particles measured to ISO16889 are identified as  $\mu\text{m}_{(c)}$

The table below reports the Beta values of Atos filter elements, according to the considered standard.

Microfibre filter element	$\beta_{x(c)} > 1000$ (ISO16889)	$\beta_x > 200$ (ISO4572)
F03	4.5 $\mu\text{m}_{(c)}$	3 $\mu\text{m}$
F06	7 $\mu\text{m}_{(c)}$	6 $\mu\text{m}$
F10	12 $\mu\text{m}_{(c)}$	10 $\mu\text{m}$
F20	22 $\mu\text{m}_{(c)}$	20 $\mu\text{m}$
F25	27 $\mu\text{m}_{(c)}$	25 $\mu\text{m}$

Cellulose filter element	$\beta_{x(c)} > 2$ (ISO16889)	$\beta_x > 2$ (ISO4572)
C10	10 $\mu\text{m}_{(c)}$	10 $\mu\text{m}$
C25	25 $\mu\text{m}_{(c)}$	25 $\mu\text{m}$

**Contamination classes and pressure drop values remain unchanged between ISO4572 and ISO16889**

#### 4 DIRT-HOLDING CAPACITY

The Beta ratio does not give any indication about the total amount of contaminant that can be trapped by the filter during its life.

This parameter is defined **DIRT-HOLDING CAPACITY (DHC)** and it defines the quantity of contaminant that the filter element can trap and hold before the maximum allowable back pressure or delta P level is reached.

Generally, a filter element with a larger effective filtration surface has a greater dirty holding capacity and therefore a longer service life.

#### 5 FILTRATION CIRCUIT

The solid contamination caused by normal component's wear is the main source of fluid contamination.

To avoid malfunctioning and progressive deterioration of the components installed in the hydraulic system, a proper filtration circuit has to be designed.

The following recommendations support the user in designing of an optimized filtration circuit.

The table below suggests the selection of a filtration circuit according to the targeted contamination class, see section 1 for recommended contamination classes.

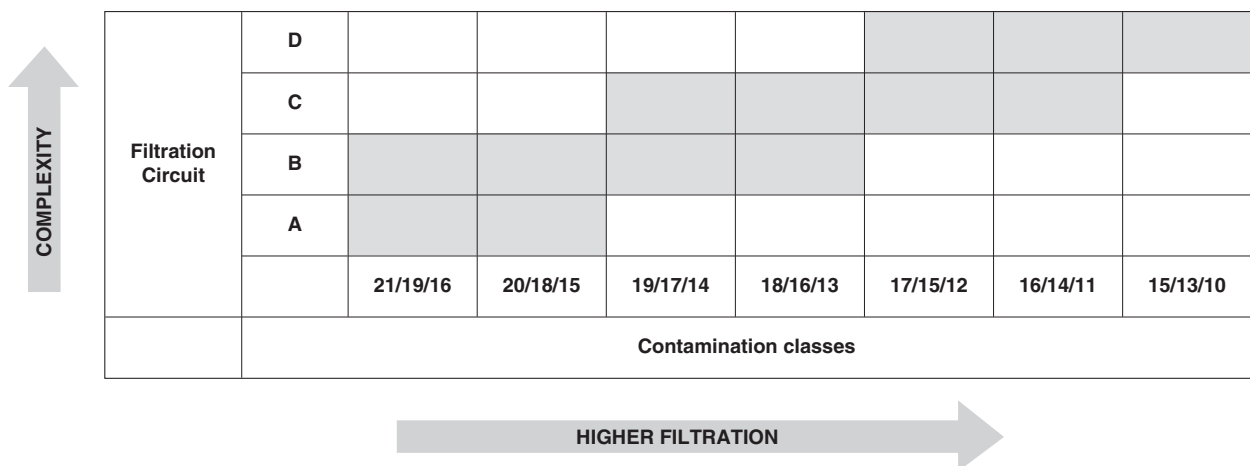

General rules to be followed to ensure optimal operating conditions for the hydraulic systems:

- the hydraulic tank has to be properly designed to limit the ingress of external contamination
- maintenance operations must be performed to avoid the ingress of contamination.

Consult Atos technical office for additional support for proper design of filtration circuits.

### CIRCUIT A

**Return line filter** ensures that all the contaminants generated during system operations are correctly filtered before entering the tank. It is a cost effective solution mainly used in systems with on-off valves.

This configuration can't ensure protection of hydraulic components from wear generated by the pump.

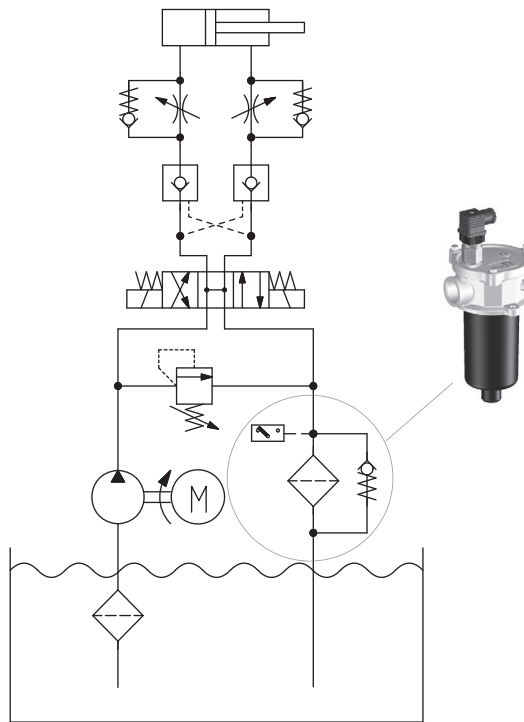

### CIRCUIT B

**In line filter** is normally installed immediately after the pump, to guarantee a correct filtration of the fluid before it reaches the hydraulic components.

It is a solution particularly used to protect proportional and servoproportional valves.

This configuration can't ensure protection of hydraulic components from contaminants generated further downstream and of the pump from dirt returned to the tank.

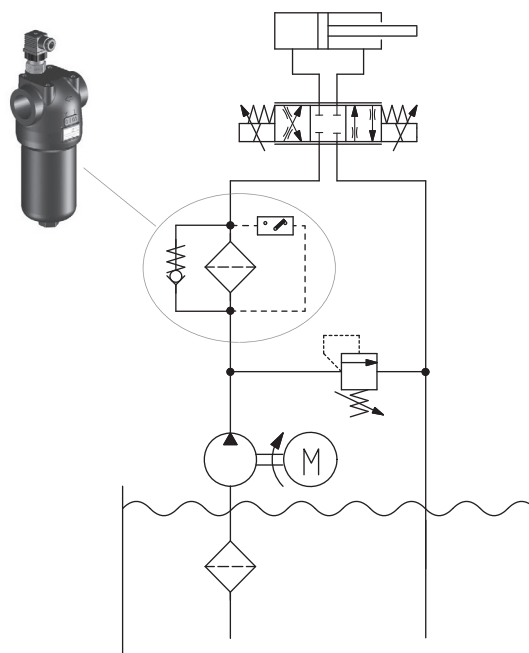

### CIRCUIT C

This example shows a circuit with **both in line and return line filters**.  
It is an ideal solution to enhance the whole system efficiency.

This system configuration will ensure:

- correct protection of components from wear generated by the pump
- correct filtration of the fluid flowing back to the tank, removing all the contamination entered in the system as consequence of components wear.

An efficient contamination control is guaranteed if the whole pump flow is passing through the filters.

As consequence, this system configuration is not indicated for circuits with variable displacement pumps operating for long time in null flow.

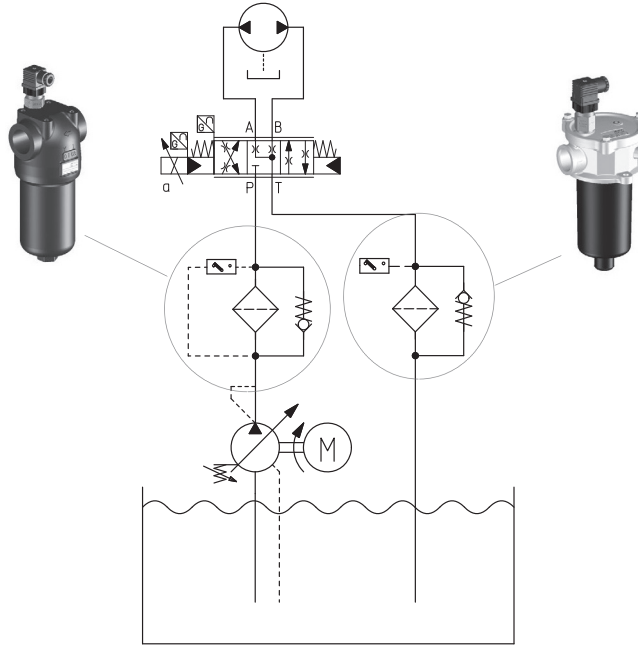

### CIRCUIT D

This example is similar to circuit C but implemented with an **additional off-line filtration system**.

It is an ideal solution when wide change in system flow rates are expected or for systems equipped with variable displacement pumps operating for long time in null flow.

The additional off-line filtration system allows to maintain a constant filtration of the fluid in the tank, avoiding the accumulation of contamination particles

This system configuration will ensure:

- excellent cleanliness level, independently of the operating cycles of the main circuit
- higher dirt-holding capacity along with higher filtration efficiency
- easier maintenance operations thanks to the possibility of replacing the filter element without stopping the machine.

To protect critical components like servoproportional valves, in line filter without by-pass valves is suggested.

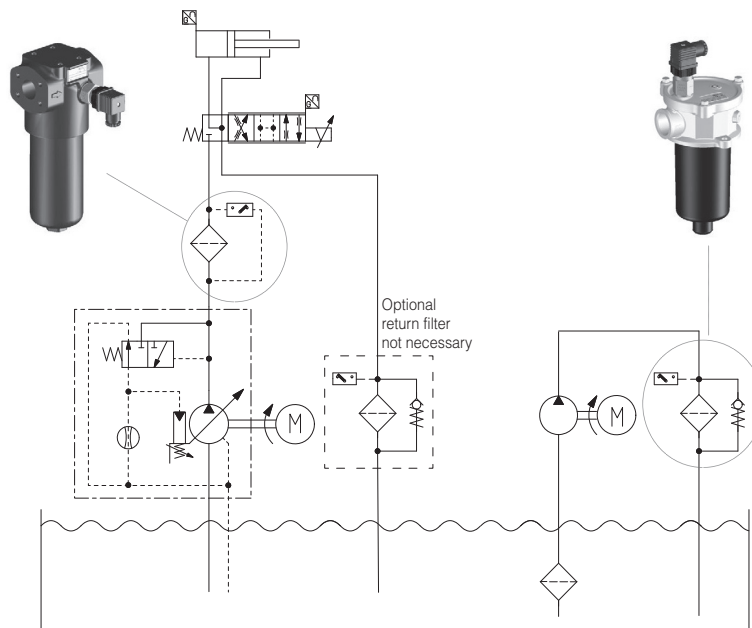

## 6 CLOGGING INDICATORS

They notify to the operator when the filter element is near to be clogged and then it must be replaced. Their use is recommended for in line and return line filters to avoid that the high pressure caused by the clogged filter element causes the filter by-pass opening and the consequent release of contaminants into the hydraulic circuit.

Depending on the type of hydraulic filter, different clogging indicators are used:

- **Visual indicator**, Atos type **CIA-V**, normally used with **return line filters**

It is a pressure gauge which measures the pressure before the filter element and indicates the clogged condition by means of coloured sectors:

**Green** (range 0 to 3 bar) = filter element in good condition;

**Red** (> 3 ) = filter element to be immediately replaced

It requires a constant visual inspection by the operator to verify the filter condition



CIA-V

- **Electrical indicator**, Atos type **CIA-E**, normally used with **return line filters**

It is a pressure switch which measures the pressure before the filter element and it indicates the clogged condition by means of switching contact (NO or NC)

The switching pressure if factory set at 2 bar corresponding to 70% of the by-pass valve cracking pressure

The electric contact is normally interfaced with the machine CNC for the automatic monitoring of the filter condition



CIA-E

- **Visual differential indicator**, Atos type **CID-V**, normally used with **in line filters**

It is a pressure switch which measures the  $\Delta p$  across the filter element and it indicates the clogged condition by means of coloured bands:

**Green** = filter element in good condition;

**Red** = filter element to be immediately replaced

The switching pressure if factory set at 5 bar corresponding to 80% of the by-pass valve cracking pressure

For filters without by-pass valve the switching pressure if factory set at 8 bar

It requires a constant visual inspection by the operator to verify the filter condition



CID-V

- **Electrical differential indicator**, Atos type **CID-M**, normally used with **in line filters**

It is a pressure switch which measures the  $\Delta p$  across the filter element and it indicates the clogged condition by means of switching contact (NO or NC)

The switching pressure if factory set at 5 bar corresponding to 80% of the by-pass valve cracking pressure

For filters without by-pass valve the switching pressure if factory set at 8 bar

The electric contact is normally interfaced with the machine CNC for the automatic monitoring of the filter condition

Optional version, Atos code **CID-L**, is provided with additional LED to indicate the filter clogged condition



CID-E

### Notes about Electrical differential indicator function

The electrical differential clogging indicator switches at pressure P1, signalling the necessity to replace the filter element, before the by-pass valve cracking pressure P2.

To protect the system from contamination, the set value P1 of the clogging indicator is always lower than the cracking pressure P2 of the by-pass valve.

For in line filters without by-pass valve, the continued operation at higher  $\Delta p$  can cause the degradation of the filtration performances (point A in the diagram). In the worst case the filter element may collapse, losing its integrity (point B in the below diagram).

For this reason, in line filters without by-pass valves are usually provided with filter element having high collapse pressure value.

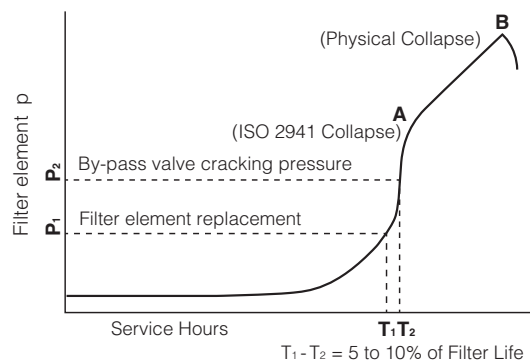

## 7 ISO STANDARDS

The following lists is intended to provide a documentation of the actual ISO norms relevant to hydraulic filtration

**ISO 2941** Hydraulic fluid power – Filter element – verification of collapse/burst pressure rating

**ISO 2942** Hydraulic fluid power – Filter element – verification of fabrication integrity and determination of the first bubble point

**ISO 2943** Hydraulic fluid power – Filter element – verification of material compatibility with fluids

**ISO 3723** Hydraulic fluid power – Filter element – method for end load test

**ISO 3724** Hydraulic fluid power – Filter element – determination of resistance to flow fatigue using particulate contaminant

**ISO 3968** Hydraulic fluid power – Filters – evaluation of differential pressure versus flow characteristics

**ISO 4406** Hydraulic fluid power – Fluids – method for coding the level of contamination by solid

**ISO 16889** Hydraulic fluid power – Filters – multi-pass method for evaluating filtration performance of a filter element

**ISO 23181** Hydraulic fluid power – Filter element – determination of resistance to flow fatigue using high viscosity fluid

**ISO 11170** Hydraulic fluid power – sequence of tests for verifying performance characteristics of filter elements

**ISO 10771-1** Hydraulic fluid power – fatigue pressure testing of metal pressure-containing envelopes – test method



# In line filters, high pressure type FPS

Threaded ports

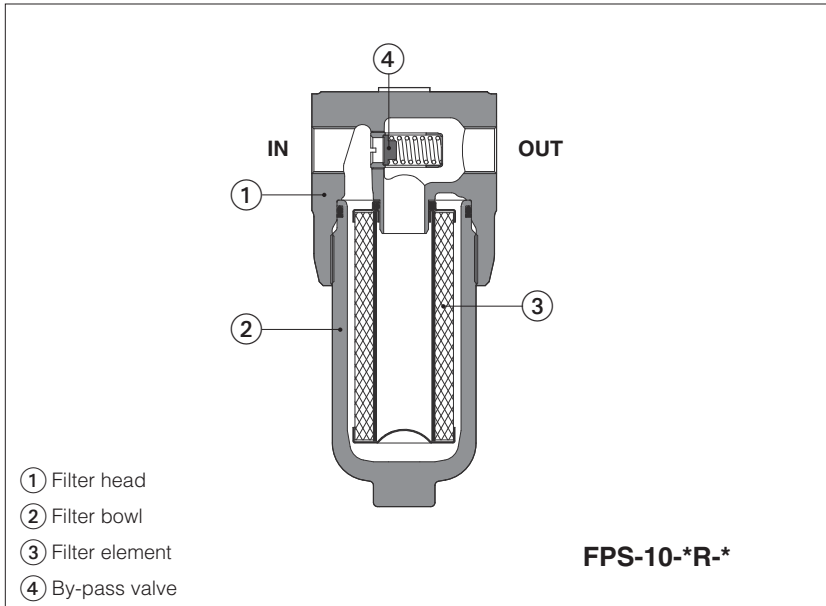

**FPS**

In line filters are designed for installation on the pressure line downstream the pump, to ensure a high cleanliness of the fluid circulating into the hydraulic system. They protect sensible components from contamination present in the working fluid and they are particularly recommended for systems with proportional valves.

- three head sizes
- threaded port sizes:  
G1/2" to G1 1/2"  
SAE-16, SAE-20, SAE-24
- high efficiency microfiber elements. Collapse pressure 21 bar for filters equipped with by-pass valve or 210 bar for filters without by-pass
- filtration rating 4,5 - 7 - 12 - 22 μm(c) (βx(c) >1000, ISO 16889).
- versions without or with by-pass valve with cracking pressure 6 bar.
- without or with differential clogging indicator

Max flow **440 l/min**  
Max working pressure **420 bar**

**1 MODEL CODE OF COMPLETE FILTERS**

<b>FPS</b>	-	<b>10</b>	-	<b>A</b>	-	<b>F10</b>	-	<b>01</b>	-	<b>R</b>	-	<b>*</b>	-	<b>W</b>	<b>*</b>	/	<b>*</b>
In line filter, high pressure															Series number		Seals material: - = NBR <b>PE</b> = FKM
<b>Filter size:</b> 10 = ports size 1/2" ÷ 1" 20 = ports size 1" ÷ 1 1/4" 30 = ports size 1 1/4" ÷ 1 1/2"																	
<b>Filter</b>																	
<b>length:</b>																	
<b>A</b> =	110	191	240														
<b>B</b> =	133	205	349														
<b>C</b> =	-	226	390														
<b>D</b> =	-	-	440														
<b>Filter element:</b> SN = only body, without filter element Microfibre filter element βx(c) >1000 - ISO 16889: F03 = 4,5 μm (c); F10 = 12 μm (c); F06 = 7 μm (c) F20 = 22 μm (c)																	
<b>Ports size:</b>																	
BSPP	00 = G 1/2"	02 = G 1"	03 = G 1 1/4"														
threaded:	01 = G 3/4"	03 = G 1 1/4"	04 = G 1 1/2"														
	02 = G 1"																
SAE J1926-1	FPS-10	FPS-20	FPS-30														
threaded:	42 = SAE-16 (1")	43 = SAE-20 (1 1/4")	44 = SAE-24 (1 1/2")														
<b>Differential clogging indicator</b> see sect. 14: W = without, indicator port with plastic plug (2) P = without, indicator port with steel plug L = electrical indicator with LED (3) M = electrical indicator without LED (3) V = visual indicator (3) <b>see also note (4)</b>																	
<b>Options</b> see sect. 10: - = none AR = anti-back flow valve and reverse valve																	
<b>By-pass valve</b> see sect. 9: R = by-pass valve with cracking pressure 6 bar (filter element PSH-*R with collapse pressure 21 bar) N = without by-pass (filter element PSH-*N with collapse pressure 210 bar)																	

**Note:** filters for use in potentially explosive atmosphere are available on request, contact Atos Technical Office

- (1) Max flow rates are measured with: Δp 1 bar, filter element F20, largest port size, option -R, oil viscosity 32 mm<sup>2</sup>/s - see also section 6  
In case of different conditions see section 11 for filter sizing
- (2) The plastic plug (option W) is only intended to prevent impurities from entering the filter through the clogging indicator port. A clogging indicator must be fitted on the filter before commissioning. Do not install the filter with the plastic cap on the hydraulic system
- (3) The clogging indicator is supplied disassembled from the filter. The indicator port on filter head is plugged with plastic plug
- (4) Differential thermostated indicator CID-T and differential electronic transmitter CID-Z are available on request, see section 4

**2 HYDRAULIC SYMBOLS** (representation according to ISO 1219-1)

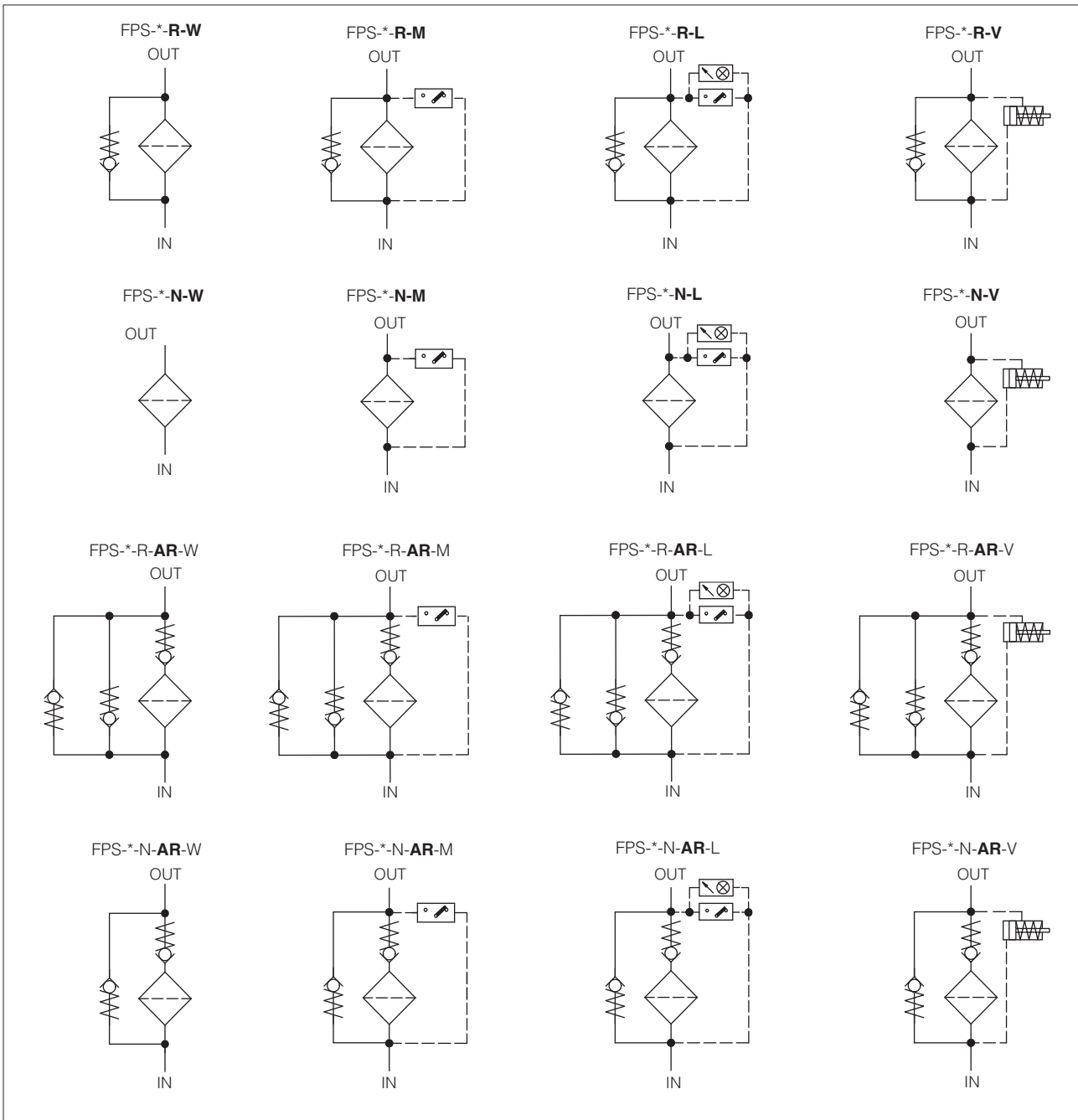

**3 MODEL CODE OF FILTER ELEMENTS - only for spare (1)**

<b>PSH</b>	-	<b>10</b>	-	<b>A</b>	-	<b>F10</b>	-	<b>R</b>	/	<b>*</b>
Spare filter element for in line filter type FPS										Seals material: - = NBR <b>PE</b> = FKM
Series number										
<p><b>Filter element size:</b>  <b>10</b> = for FPS-10  <b>20</b> = for FPS-20  <b>30</b> = for FPS-30</p>										
<p><b>Filter element length:</b>  for FPS-10      for FPS-20      for FPS-30  <b>A</b>              <b>A</b>              <b>A</b>  <b>B</b>              <b>B</b>              <b>B</b>                      <b>C</b>              <b>C</b>                                   <b>D</b></p>										
<p><b>Microfibre filter element, <math>\beta_{x(c)} &gt; 1000</math> - ISO 16889:</b>  <b>F03</b> = 4,5 <math>\mu\text{m}</math> (c)  <b>F06</b> = 7 <math>\mu\text{m}</math> (c)  <b>F10</b> = 12 <math>\mu\text{m}</math> (c)  <b>F20</b> = 22 <math>\mu\text{m}</math> (c)</p>										

(1) Select the filter element according to the model code reported on the filter nameplate, see section 17.2

**4 MODEL CODE OF DIFFERENTIAL CLOGGING INDICATORS** - only for spare - see section 14 and 15

<b>CID</b>	-	<b>E</b>	<b>05</b>	-	<b>M</b>	<b>*</b>	/	<b>*</b>	
Spare differential clogging indicator for in line filter						Series number		Seals material: - = NBR <b>PE</b> = FKM	
<b>Type of indicator:</b> <b>E</b> = electrical <b>V</b> = visual <b>T</b> = thermostated (available on request) <b>Z</b> = electronic transmitter (available on request)									
<b>Differential switching pressure</b> (only for CID-E and CID-V): <b>05</b> = 5 bar for filters with by-pass valve <b>08</b> = 8 bar for filters without by-pass valve				<b>Optional LED</b> - only for CID-E <b>L</b> = with LED <b>M</b> = without LED					

**5 GENERAL CHARACTERISTICS**

Assembly position / location	Vertical position with the bowl downward
Ambient temperature range	<b>Standard</b> = -20°C ÷ +70°C <b>/PE option</b> = -20°C ÷ +70°C
Storage temperature range	<b>Standard</b> = -20°C ÷ +80°C <b>/PE option</b> = -20°C ÷ +80°C
Materials	Filter head: Cast iron Filter bowl: Carbon steel
Surface protection	Zinc coating with black passivation
Corrosion resistance	Salt spray test (EN ISO 9227) > 600 h
Fatigue strength	min. 1 x 10 <sup>6</sup> cycles at 420 bar
Compliance	RoHS Directive 2011/65/EU as last update by 2015/863/EU REACH Regulation (EC) n°1907/2006

**6 HYDRAULICS CHARACTERISTICS** - based on mineral oil ISO VG 46 at 50 °C (viscosity 32mm<sup>2</sup>/s)

Filter size	FPS-10				FPS-20			FPS-30		
	00	01	02	42	02	03	43	03	04	44
Ports size code	G1/2"	G3/4	G1"	SAE-16	G1"	G1"1/4	SAE-20	G1"1/4	G1"1/2	SAE-24
Ports dimension										
Filter length	<b>A ÷ B</b>	<b>A ÷ B</b>	<b>A ÷ B</b>	<b>A ÷ C</b>	<b>A ÷ C</b>	<b>A ÷ C</b>	<b>A ÷ D</b>	<b>A ÷ D</b>	<b>A ÷ D</b>	<b>A ÷ D</b>
Max flow (l/min) at Δp= 1 bar Filter with by-pass <b>-R</b> (see note)	<b>F03</b>	28÷45	30÷50	34÷56	55-82	59÷90	64÷200	66÷210		
	<b>F06</b>	48÷66	53÷75	60÷92	100÷135	112÷154	110÷284	113÷305		
	<b>F10</b>	60÷77	68÷89	80÷114	135÷170	154÷195	175÷342	183÷370		
	<b>F20</b>	75÷85	87÷99	110÷133	166÷196	191÷226	227÷323	240÷440		
Max flow (l/min) at Δp= 1 bar Filter without by-pass <b>-N</b> (see note)	<b>F03</b>	25-42	25÷46	29÷51	44÷67	47÷73	57÷167	58÷175		
	<b>F06</b>	35÷55	38÷68	41÷80	83÷116	91÷131	77÷228	80÷243		
	<b>F10</b>	55÷70	60÷81	71÷102	117÷153	133÷176	153÷267	160÷286		
	<b>F20</b>	69÷83	79÷96	98÷127	154÷187	177÷215	197÷372	208÷405		
Max operating pressure [bar]	<b>420</b>									
Burst pressure [bar]	<b>&gt; 1260</b>									

**Note:** Max flow rates are measured with min and max filter length. In case of different conditions see section 11 for filter sizing

**7 FILTER ELEMENTS**

Material		Inorganic microfibre
Filtration rating as per ISO16889	<b>F03</b>	$\beta_{4,5\mu m(c)} \geq 1000$
	<b>F06</b>	$\beta_{7\mu m(c)} \geq 1000$
	<b>F10</b>	$\beta_{12\mu m(c)} \geq 1000$
	<b>F20</b>	$\beta_{22\mu m(c)} \geq 1000$
Filter element collapse pressure	<b>R</b> = for filter with by-pass valve <b>N</b> = for filter without by-pass valve	21 bar 210 bar

**8 SEALS AND HYDRAULIC FLUIDS** - for other fluids not included in below table, consult our technical office

Seals, recommended fluid temperature	NBR seals (standard) = -30°C ÷ +100°C, with HFC hydraulic fluids = +10°C ÷ +50°C FKM seals (/PE option) = -25°C ÷ +120°C		
Recommended viscosity	15 ÷ 100 mm <sup>2</sup> /s - max allowed range 2.8 ÷ 500 mm <sup>2</sup> /s		
<b>Hydraulic fluid</b>	<b>Suitable seals type</b>	<b>Classification</b>	<b>Ref. Standard</b>
Mineral oils	NBR, FKM	HL, HLP, HLPD, HVLP, HVLDP	DIN 51524
Flame resistant without water	FKM	HFDU, HFDR	ISO 12922
Flame resistant with water	NBR	HFC	

**9 BY-PASS VALVE**

**Filter with by-pass valve - version -R**

The filter with by-pass valve ① is used in combination with filter elements PSH-\*-R with collapse pressure 21 bar.

The by-pass valve allows the oil flow to by-pass the filter element in particular conditions:

- it protects the filter element from pressure peaks that could be generated, especially at the cold system start-up. In these cases the valve opens only for the instant necessary to discharge the pressure peak, limiting the quantity of oil that bypasses the filter.
- it allows the free passage of the oil flow in case of completely clogged filter element ( $\Delta p > 6$  bar).

This situation should be carefully avoided, by means of a scheduled maintenance, otherwise the contaminated oil will pass to the clean side of the filter and then it will circulate in the hydraulic system. The filter element must be replaced before the clogging condition, at this purpose the use of a differential clogging indicator CID-V (visual, option V) or CID-E (electrical, options L or M) is highly recommended.

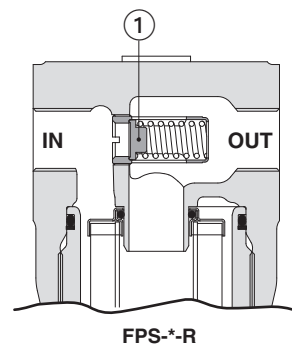

FPS-\*-R

**Filter without by-pass valve - version -N**

The filter version without by-pass is recommended when the hydraulic system must be absolutely protected by contamination, then avoiding the risk that the contaminant passes through the by-pass valve.

The filter without by pass must be used in combination with filter elements PSH-N with high collapse pressure 210 bar

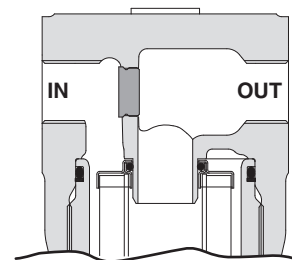

FPS-\*-N

**10 ANTI BACK-FLOW AND REVERSE VALVE**

**Anti-back flow and Reverse valves - version -AR**

The filter version -AR allows the oil flow to return from the pressure line back to the pump.

The return flow passes from the OUT port to the IN port of the filter through the reverse valve ③, bypassing the filter element.

The anti-back flow valve ② prevents the flow passing through the filter element in reverse direction, removing the accumulated contaminant.

Version **AR** is available for filters with by-pass (FPS-\*-R-AR) or without by-pass (FPS-\*-N-AR)

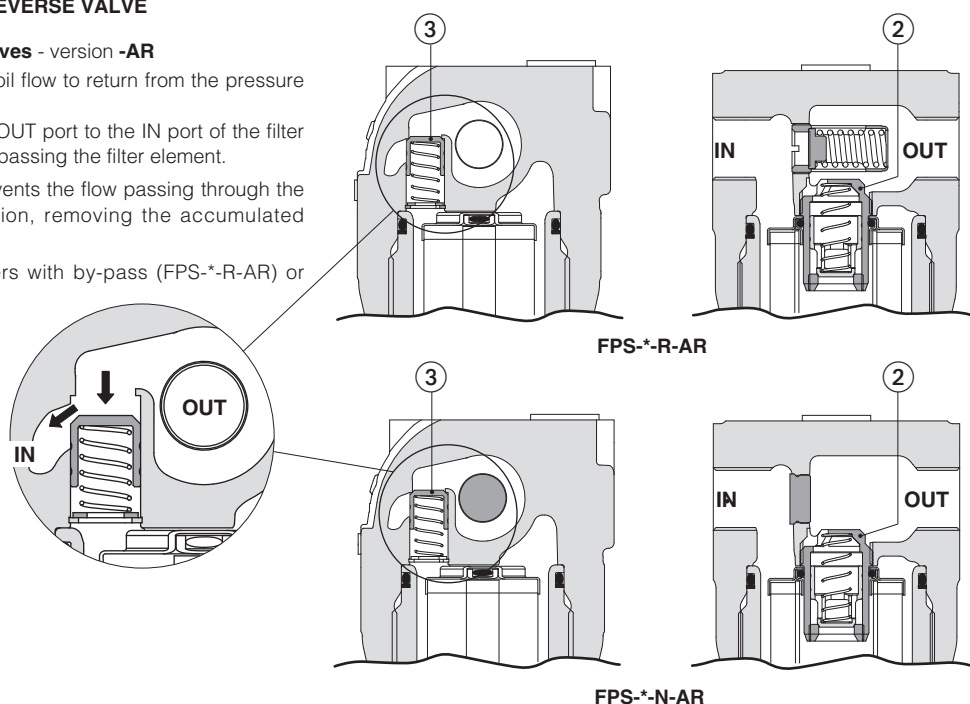

FPS-\*-R-AR

FPS-\*-N-AR

## 11 FILTERS SIZING

For the filter sizing it is necessary to consider the Total  $\Delta p$  at the maximum flow at which the filter must work.

The Total  $\Delta p$  is given by the sum of filter head  $\Delta p$  plus the filter element  $\Delta p$ :

$$\text{Total } \Delta p = \text{filter head } \Delta p + \text{filter element } \Delta p$$

In the best conditions the total  $\Delta p$  should not exceed 1,0 bar

See below sections to calculate the  $\Delta p$  of filter head and  $\Delta p$  of the filter element

### 11.1 Q/ $\Delta p$ DIAGRAMS OF FILTER HEAD

The pressure drop of filter head mainly depends on the ports size and fluid density

In the following diagrams are reported the  $\Delta p$  characteristics of filter head based on mineral oil with density 0,86 kg/dm<sup>3</sup> and viscosity 30 mm<sup>2</sup>/s

#### FPS-10

- 1 = FPS-10\*\*\* 00 (G 1/2")
- 2 = FPS-10\*\*\* 01 (G 3/4")
- 3 = FPS-10\*\*\* 02 (G 1")  
FPS-10\*\*\* 42 (SAE-16)

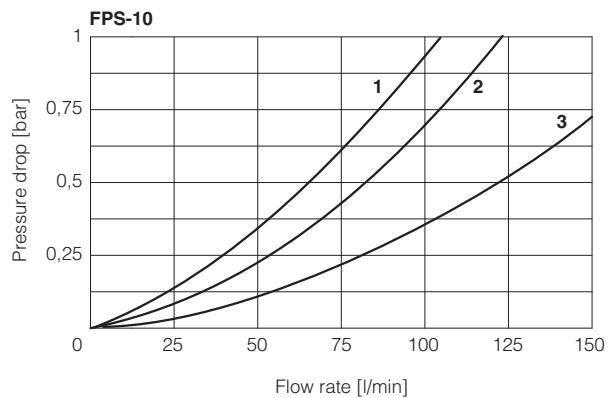

#### FPS-20

- 4 = FPS-20\*\*\* 02 (G 1")
- 5 = FPS-20\*\*\* 03 (G 1 1/4")  
FPS-20\*\*\* 43 (SAE-20)

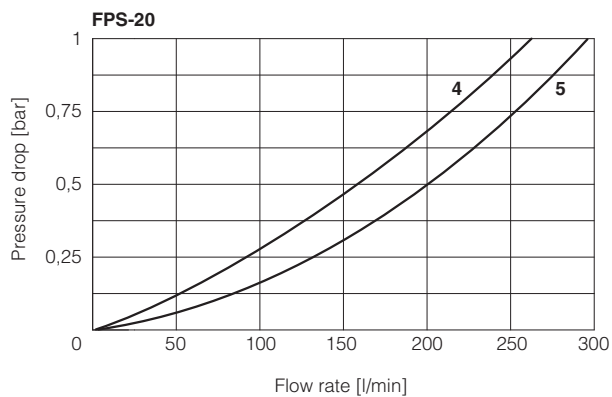

#### FPS-30

- 6 = FPS-30\*\*\* 03 (G 1 1/4")
- 7 = FPS-30\*\*\* 04 (G 1 1/2")  
FPS-30\*\*\* 44 (SAE-24)

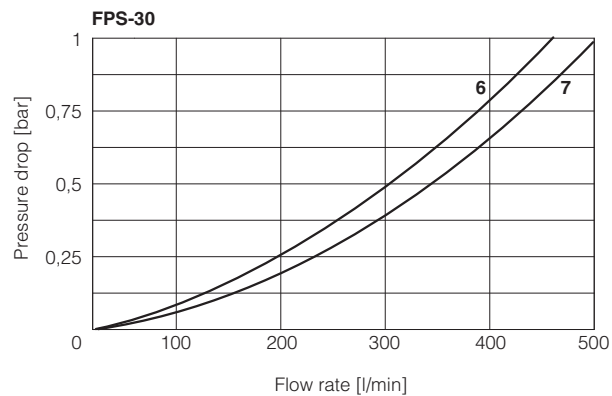

### 11.2 FILTER ELEMENT $\Delta p$

The pressure drop through the filter depends to:

- size of filter element
- filtration rating
- fluid viscosity

The  $\Delta p$  of filter element is given by the formula:

$$\Delta p \text{ of filter element} = Q \times \frac{Gc}{1000} \times \frac{\text{Viscosity}}{32}$$

**Q** = working flow (l/min)

**Gc** = Gradient coefficient (mbar/(l/min)).

The Gc values are reported in the following table

**Viscosity** = effective fluid viscosity in the working conditions (mm<sup>2</sup>/s)

#### Gradient coefficient Gc of PSH filter elements

Filter element size		10		20			30			
Filter element length		A	B	A	B	C	A	B	C	D
Filter element type	Filtration rating	Gc Gradient coefficient								
<b>R</b> for filter with bypass valve	<b>F03</b>	27.75	15.25	15.82	13.19	9.63	14	7.13	4.7	3.62
	<b>F06</b>	15.12	7.58	7.27	6.06	4.43	8.03	3.37	2.2	1.89
	<b>F10</b>	9.37	4.91	4.45	3.71	2.71	4.43	2.33	1.5	1.12
	<b>F20</b>	5.31	3.25	2.87	2.39	1.75	2.95	1.34	0.92	0.44
<b>N</b> for filter without bypass valve	<b>F03</b>	32.2	17.32	20.27	16.90	12.35	16.48	8.13	5.5	4.71
	<b>F06</b>	22.38	9.41	9.50	7.92	5.79	11.88	4.18	3.28	2.91
	<b>F10</b>	11.2	6.27	5.66	4.72	3.45	5.27	3.45	2.36	2.15
	<b>F20</b>	6.81	3.71	3.41	2.84	2.07	3.70	1.60	0.86	0.78

#### Example:

Calculation of Total  $\Delta p$  for filter type FPS-10-B-F10-02-R at Q = 80 l/min and viscosity 46 mm<sup>2</sup>/s (filter element PSH-10-B-F10-R)

**Dp** of filter head + filter bowl = 0,24 bar

**Gc** = 4,91 mbar/(l/min)

$$\text{Filter element } \Delta p = 80 \times \frac{4,91}{1000} \times \frac{46}{32} = 0,60 \text{ bar}$$

**Total  $\Delta p$  = 0,24 + 0,60 = 0,84 bar**

#### 12 BY-PASS VALVE - based on mineral oil ISO VG46 at 50°C (viscosity = 32 mm<sup>2</sup>/s)

Q/ $\Delta p$  diagrams of flow through the by-pass valve

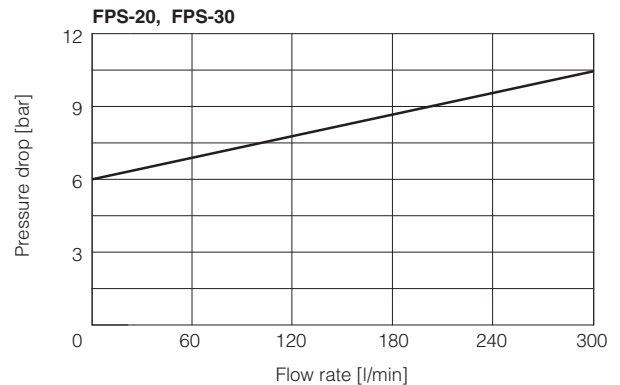
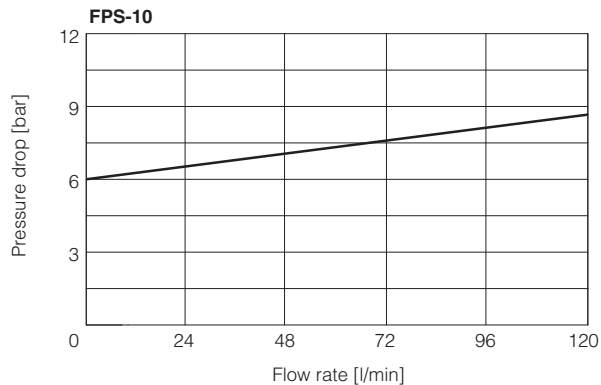

### FPS -10

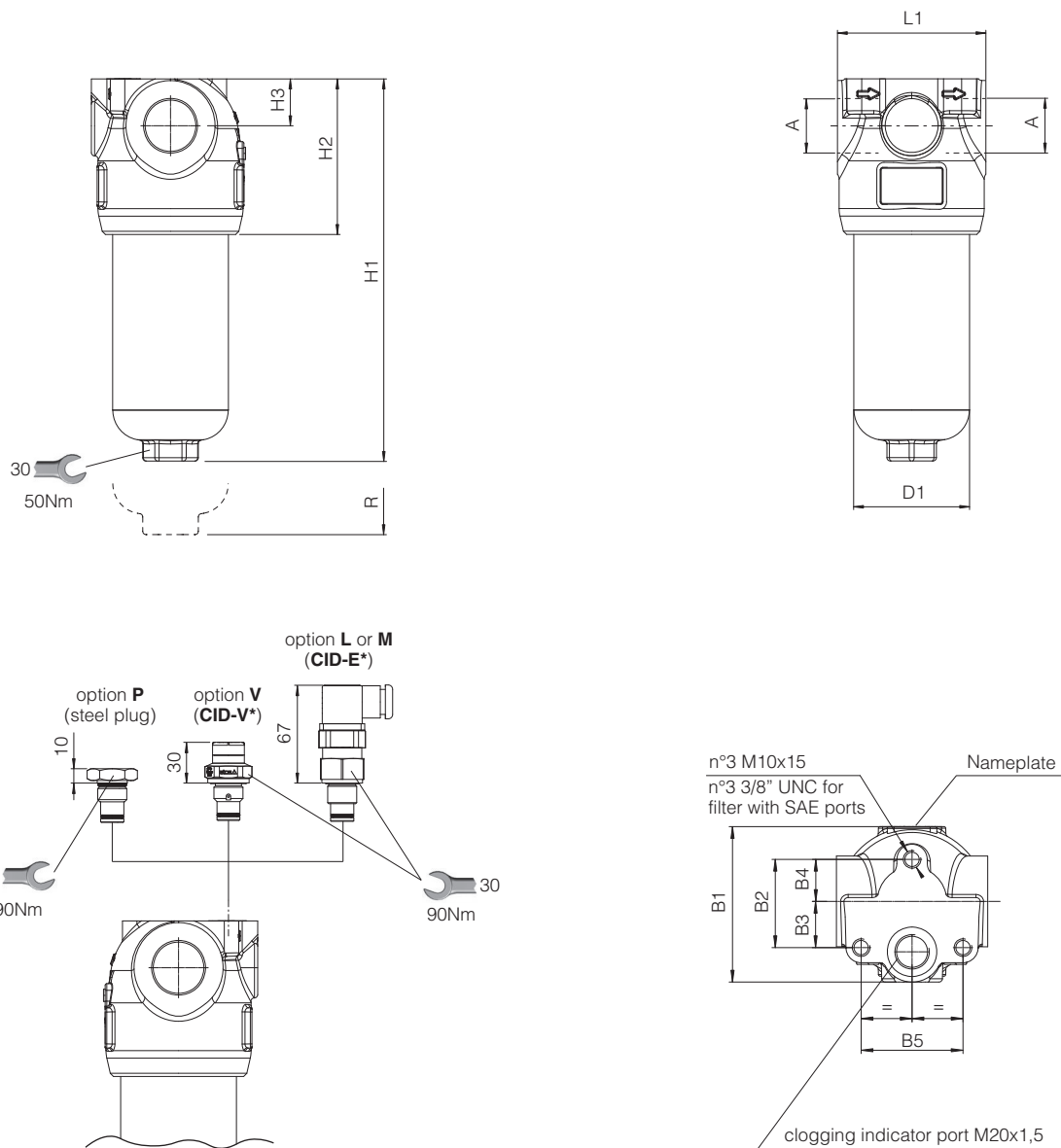

Code	A	B1	B2	B3	B4	B5	D1	H1	H2	H3	L1	R (element removal)	Mass (Kg)
FPS-10-A	1/2" BSPP 3/4" BSPP 1" BSPP SAE-16	93.5	52.5	27.5	25	60.6	70	203	93	28	90	110	4
FPS-10-B								296					5

# FPS -20

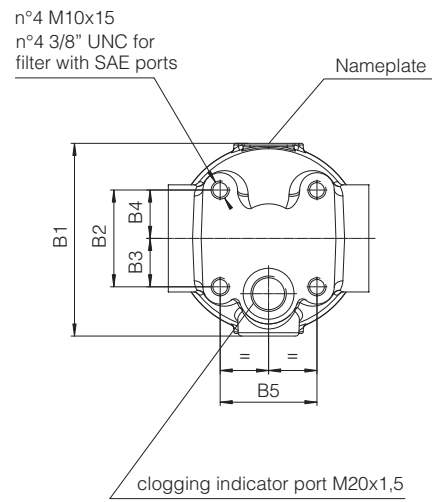
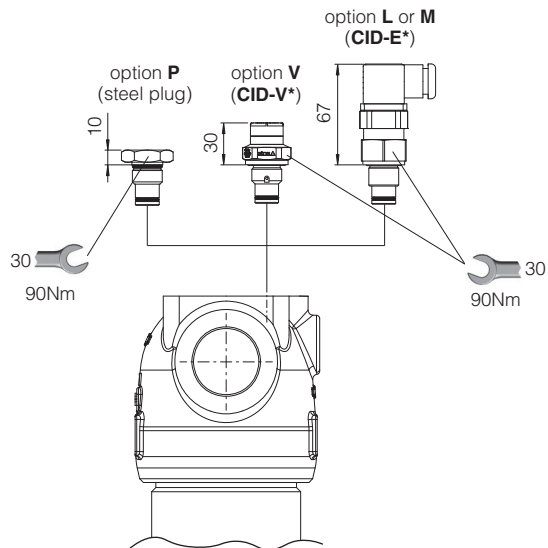
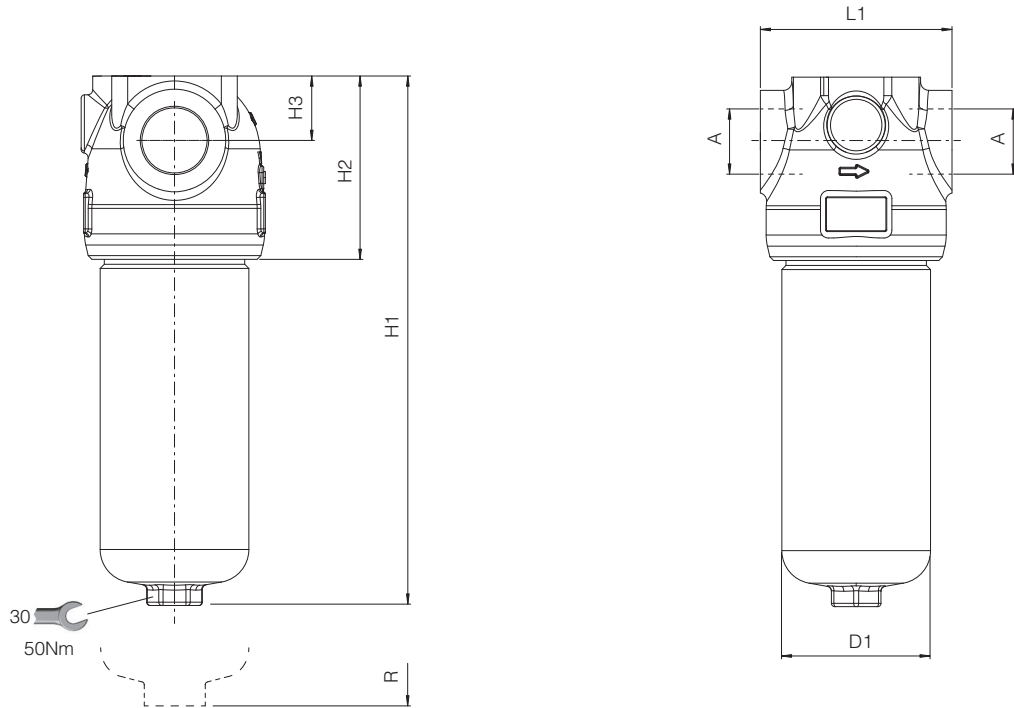

Code	A	B1	B2	B3	B4	B5	D1	H1	H2	H3	L1	R (element removal)	Mass (Kg)
FPS-20-A	1" BSPP 1 1/4" BSPP SAE-20	111.5	56	28	28	56	90	261	111	39	116	120	7.4
FPS-20-B								320					8.5
FPS-20-C								390					9.9



# FPS -30

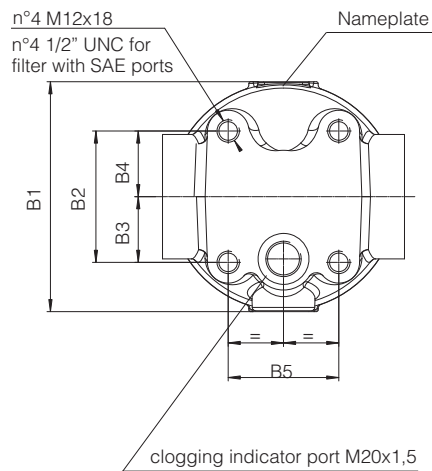
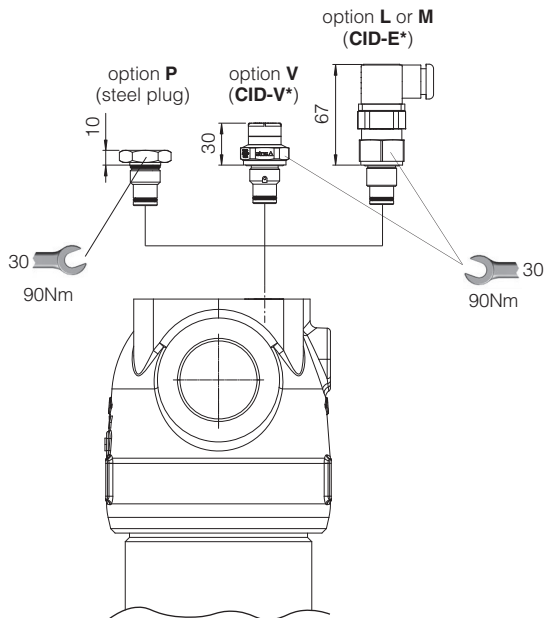
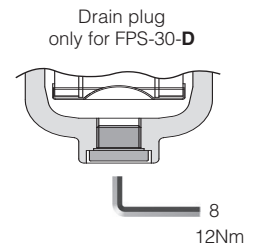
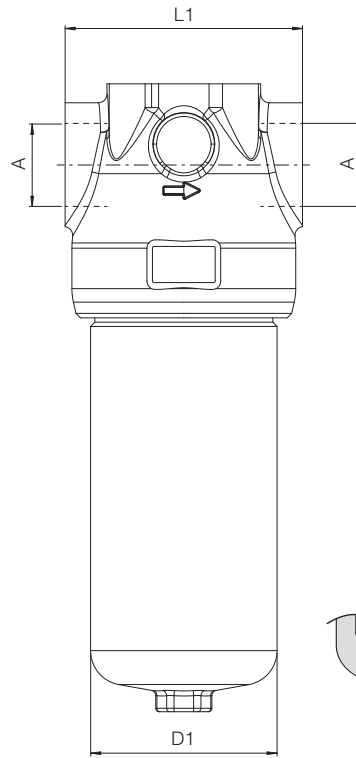
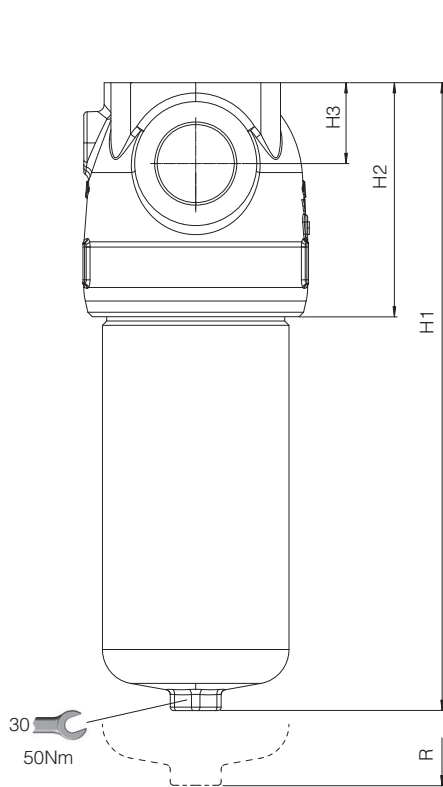

Code	A	B1	B2	B3	B4	B5	D1	H1	H2	H3	L1	R (element removal)	Mass (Kg)
FPS-30-A	1 1/4" BSPP 1 1/2 BSPP SAE-24	133.5	76	38	38	64	110	240.5	136	47	140	130	10.5
FPS-30-B								333.5					13
FPS-30-C								453.5					16.4
FPS-30-D								552.5					19

**14 CHARACTERISTICS OF DIFFERENTIAL CLOGGING INDICATORS**

Model code	CID-E* ELECTRICAL		CID-V* VISUAL
Differential switching pressure	CID-E05, CID-V05	5 bar ± 10%	5 bar ± 15%
	CID-E08, CID-V08	8 bar ± 10%	8 bar ± 10%
Max pressure	450 bar		420 bar
Max differential pressure	200 bar		
Ambient temperature	-25°C ÷ +100°C		-25°C ÷ +80°C
Hydraulic connection	M20x1,5		
Duty factor	100%		
Mechanical life	1 x 10 <sup>6</sup> operations		
Mass (Kg)	0,16		0,11
Electric connection	Electric plug connection as per DIN 43650 with cable gland type PG7		-
Power supply	CID-E05-L, CID-E08-L	24 V <sub>DC</sub> ± 10%	
	CID-E05-M, CID-E08-M	14 V <sub>DC</sub> ÷ 30 V <sub>DC</sub>	125 V <sub>AC</sub> ÷ 250 V <sub>AC</sub>
Max current - resistive (inductive)	5 A (4 A) ÷ 4 A (3 A)	5 A (3 A) ÷ 3 A (2 A)	-
Protection degree to DIN EN 60529	IP65 with mathing connector		-
Switching scheme	<b>CID*-L</b>	<b>CID*-M</b>	GREEN
	clean filter element		
Switching scheme	<b>CID*-L</b>	<b>CID*-M</b>	RED
	clogged filter element		

**15 DIMENSIONS OF DIFFERENTIAL CLOGGING INDICATORS**

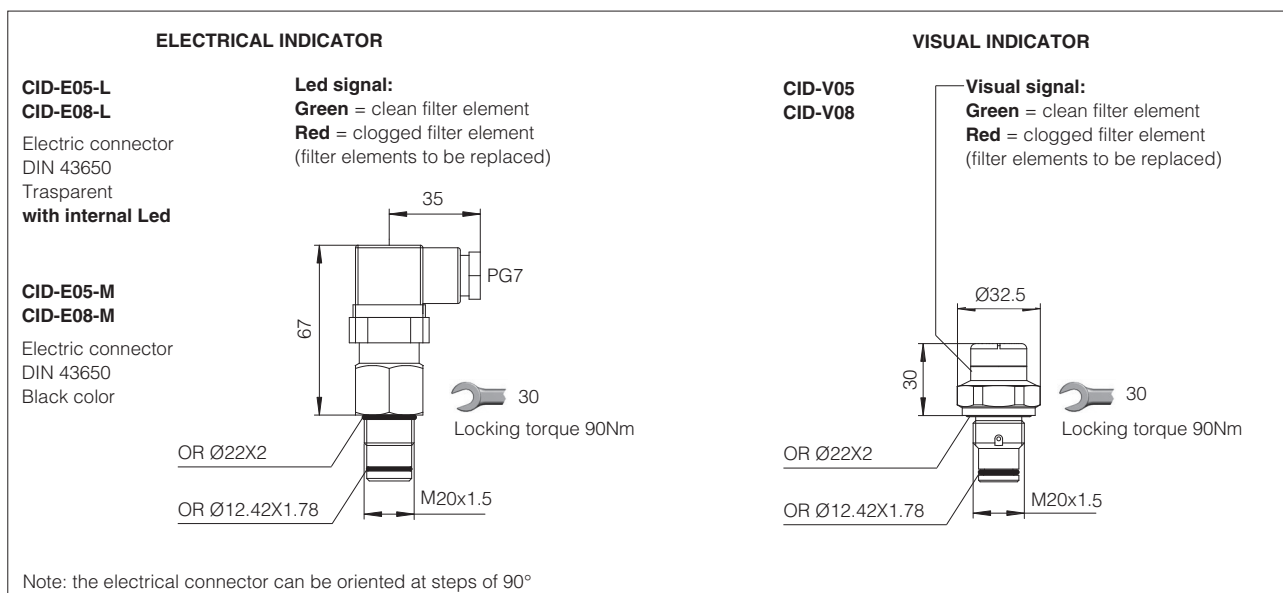

**NOTE:** Differential thermostated indicator CID-T and differential electronic transmitter CID-Z are available on request

## 16 INSTALLATION AND COMMISSIONING

The max operating pressure of the system must not exceed the max working pressure of the filter.  
 During the filter installation, pay attention to respect the flow direction, shown by the arrow on the filter head.  
 The filter should be preferably mounted with the bowl downward.  
 The filter should be properly secured using the threaded fixing holes on the filter head.  
 Make sure that there is enough space for the replacement of the filter element.  
 Never run the system without the filter element.  
 For filters ordered with clogging indicator:  
 • remove the plastic plug from the indicator port on the filter head  
 • install the clogging indicator and lock it at the specified torque  
 During the cold start up (fluid temperature lower than 30°C), a false clogging indicator signal can be given due to the high fluid viscosity.

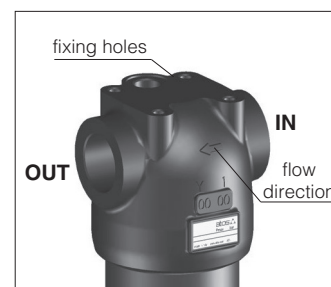

## 17 MAINTENANCE

The filter element must be replaced as soon as the clogging indicator switches to highlight the filter clogged condition.  
 For filters without clogging indicator, the filter element must be replaced according to the system manufacturer's recommendations.  
 Select the new filter element according to the model code reported on the filter nameplate, see section 17.2

For the replacement of the filter element, proceed as follow:

- releases the system pressure; the filter has no pressure bleeding device
- pay attention to the fluid and filter surface temperature. Always use suitable gloves and protection glasses
- unscrew the bowl (2) from the filter head (1) by turning counterclockwise (view from bottom side)
- remove the dirty filter element (3) pulling it carefully
- lubricate the seal of new filter element and insert it over the spigot in the filter head
- clean the bowl internally, lubricate the threads and screw by hand the bowl to the filter head by turning clockwise (view from bottom side). Tighten at the recommended torque.



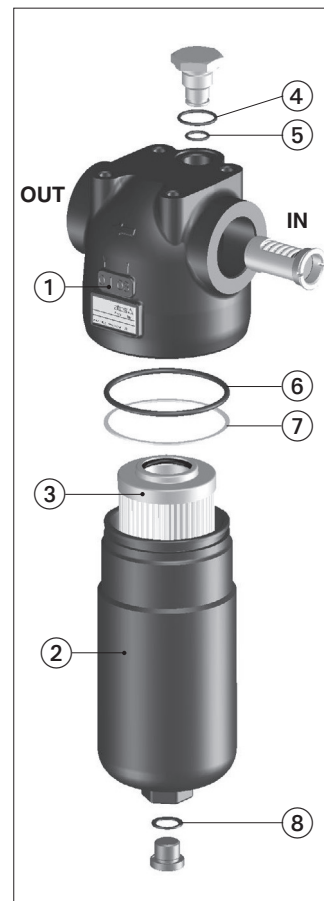

**WARNING:** The dirty filter elements cannot be cleaned and re-used. They are classified as "dangerous waste material", then they must be disposed of by authorized Companies, according to the local laws.



### 17.1 SEALS KIT

Filter type	Seal kit code	Seal kit composition
FPS-10	GUARN FPS-10	④+⑤+⑥+⑦
FPS-20	GUARN FPS-20	④+⑤+⑥+⑦
FPS-30	GUARN FPS-30	④+⑤+⑥+⑦+⑧

### 17.2 FILTER IDENTIFICATION NAMEPLATE

 19000000	 Pmax 420 bar	③
①	<b>FPS-10-A-F10-01-R-W ** /PE</b>	① Model code of complete filter
②	Filter Element: <b>PSH-10-A-F10-R ** /PE</b>	② Model code of filter element
	made in Italy    www.atos.com    AT-1192	③ Max working pressure
		④ Filter matrix code

## 18 RELATED DOCUMENTATION

<b>LF010</b>	Fluid contamination
<b>LF020</b>	Filtration guidelines



# In line filters, high pressure type FPH

SAE flanged ports

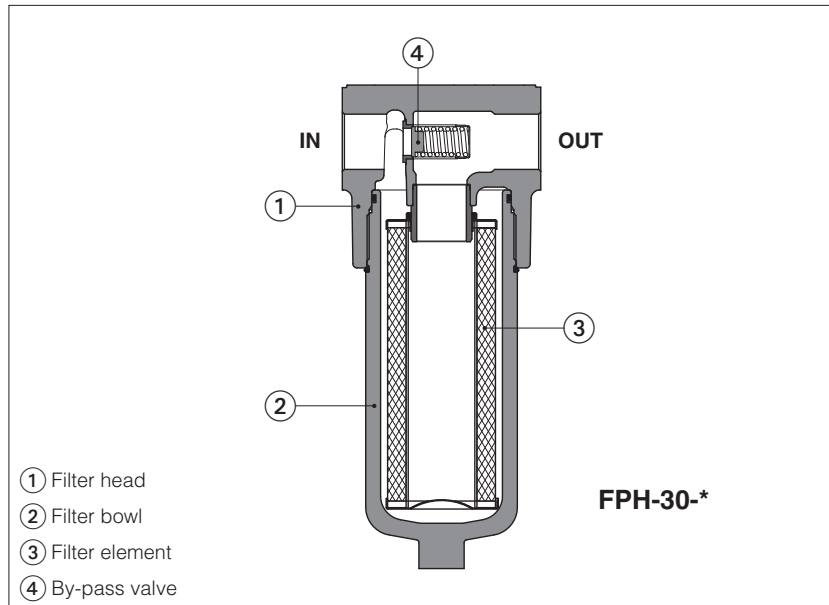

- ① Filter head
- ② Filter bowl
- ③ Filter element
- ④ By-pass valve

## FPH

In line filters are designed for installation on the pressure line downstream the pump, to ensure a high cleanliness of the fluid circulating into the hydraulic system. They protect sensible components from contamination present in the working fluid and they are particularly recommended for systems with proportional valve.

- two head sizes
- SAE 6000 flanged ports, from 3/4" to 1 1/2"
- high efficiency microfiber elements. Collapse pressure 21 bar for filters equipped with by-pass valve or 210 bar for filters without by-pass
- filtration rating 4,5 - 7 - 12 - 22 μm(c) (βx(c) >1000, ISO 16889).
- versions without or with by-pass valve with cracking pressure 6 bar.
- without or with differential clogging indicator

Max flow **400 l/min**

Max working pressure **420 bar**

## 1 MODEL CODE OF COMPLETE FILTERS

<b>FPH</b>	-	<b>10</b>	-	<b>A</b>	-	<b>F10</b>	-	<b>21</b>	-	<b>R</b>	-	<b>W</b>	/	<b>**</b>	/	<b>*</b>										
In line filter, high pressure														Series number		Seals material: - = NBR <b>PE = FKM (4)</b>										
<b>Filter size:</b> <b>10</b> = ports size 3/4" ÷ 1" SAE6000 flange <b>30</b> = ports size 1 1/4" ÷ 1 1/2" SAE6000 flange																										
<table style="width: 100%; border-collapse: collapse;"> <thead> <tr> <th style="text-align: left;">Filter length:</th> <th style="text-align: left;">Max flow [l/min] (1)</th> </tr> </thead> <tbody> <tr> <td style="padding-left: 10px;"><b>A</b> =</td> <td style="padding-left: 20px;">95      230</td> </tr> <tr> <td style="padding-left: 10px;"><b>B</b> =</td> <td style="padding-left: 20px;">115     320</td> </tr> <tr> <td style="padding-left: 10px;"><b>C</b> =</td> <td style="padding-left: 20px;">-        350</td> </tr> <tr> <td style="padding-left: 10px;"><b>D</b> =</td> <td style="padding-left: 20px;">-        400</td> </tr> </tbody> </table>																	Filter length:	Max flow [l/min] (1)	<b>A</b> =	95      230	<b>B</b> =	115     320	<b>C</b> =	-        350	<b>D</b> =	-        400
Filter length:	Max flow [l/min] (1)																									
<b>A</b> =	95      230																									
<b>B</b> =	115     320																									
<b>C</b> =	-        350																									
<b>D</b> =	-        400																									
<b>Filter element:</b> <b>SN</b> = only body, without filter element <b>Microfibre filter element</b> βx(c) >1000 - ISO 16889: <b>F03</b> = 4,5 μm (c); <b>F10</b> = 12 μm (c); <b>F06</b> = 7 μm (c) <b>F20</b> = 22 μm (c)																										
<b>Differential clogging indicator</b> see sect. 9 : <b>W</b> = without, indicator port with plastic plug (2) <b>P</b> = without, indicator port with steel plug <b>L</b> = electrical indicator with LED (3) <b>M</b> = electrical indicator without LED (3) <b>V</b> = visual indicator (3) See also note (4)																										
<b>By-pass:</b> <b>R</b> = by-pass valve with cracking pressure 6 bar (filter element with collapse pressure 21 bar) <b>N</b> = without by-pass (filter element with collapse pressure 210 bar)																										
<b>Ports size:</b> SAE 6000 flange with metric bolts: FPH-10                      FPH-30 <b>21</b> = 3/4" <b>23</b> = 1 1/4" <b>22</b> = 1" <b>24</b> = 1 1/2"																										

**Note:** filters for use in potentially explosive atmosphere are available on request, contact Atos Technical Office

- (1) Max flow rates are measured with: Δp 1 bar, filter element F20, largest port size, option -R, oil viscosity 32 mm<sup>2</sup>/s - see also section 6  
In case of different conditions see section 11 for filter sizing
- (2) The plastic plug (option W) is only intended to prevent impurities from entering the filter through the clogging indicator port. A clogging indicator must be fitted on the filter before commissioning. Do not install the filter with the plastic cap on the hydraulic system
- (3) The clogging indicator is supplied disassembled from the filter. The indicator port on filter head is plugged with plastic plug
- (4) Differential thermostated indicator CID-T and differential electronic transmitter CID-Z are available on request, see section 4

**2 HYDRAULIC SYMBOLS** (representation according to ISO 1219-1)

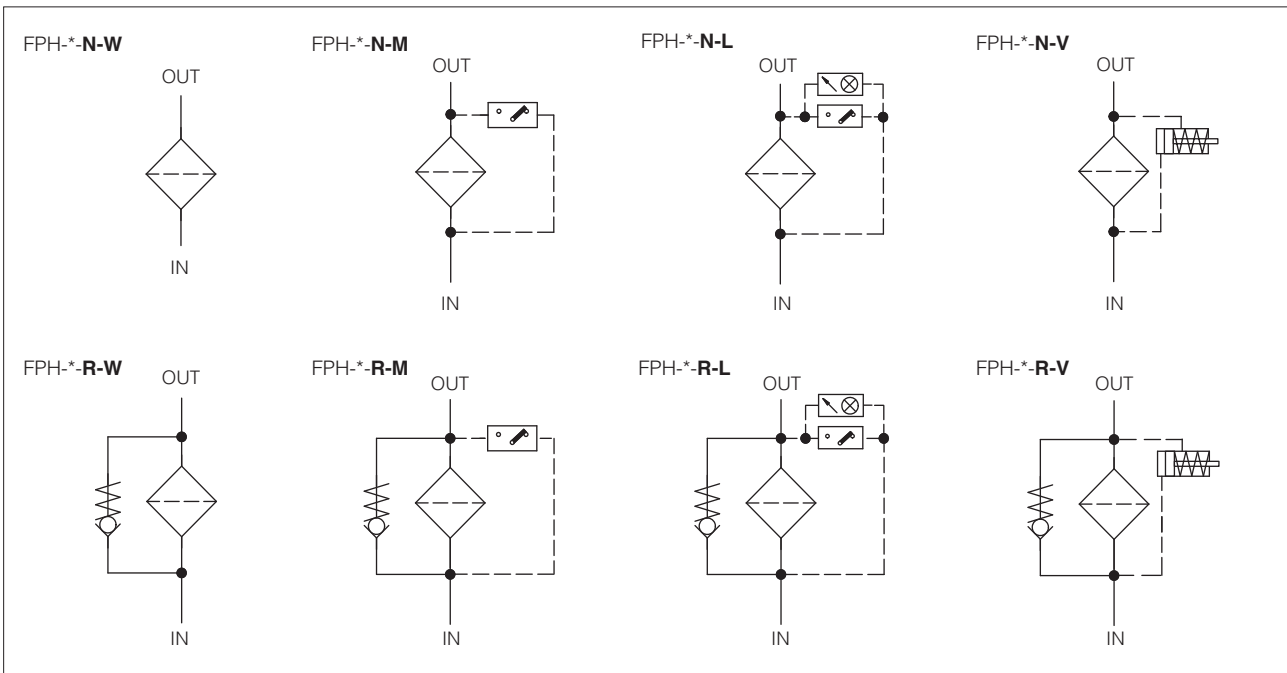

**3 MODEL CODE OF FILTER ELEMENTS** - only for spare (1)

<b>PSH</b>	-	<b>10</b>	-	<b>A</b>	-	<b>F10</b>	-	<b>R</b>	/	*	/	*
Spare filter element for in line filter type FPH										Series number		Seals material: - = NBR <b>PE</b> = FKM
<b>Filter element size:</b>												
<b>10</b> = for FPH-10 <b>30</b> = for FPH-30												
<b>Filter element length:</b>												
for FPH-10                      for FPH-30 <b>A</b> <b>A</b> <b>B</b> <b>B</b> <b>C</b> <b>D</b>												
		<b>Microfibre filter element, <math>\beta_{x(c)} &gt; 1000</math> - ISO 16889:</b> <b>F03</b> = 4,5 $\mu\text{m}$ (c) <b>F06</b> = 7 $\mu\text{m}$ (c) <b>F10</b> = 12 $\mu\text{m}$ (c) <b>F20</b> = 22 $\mu\text{m}$ (c)										
		<b>R</b> = filter element with collapse pressure 21 bar, for filter FPH-*-R with by-pass valve <b>N</b> = filter element with collapse pressure 210 bar, for filter FPH-*-N without by-pass valve										

(1) Select the filter element according to the model code reported on the filter nameplate, see section 16.2

**4 MODEL CODE OF DIFFERENTIAL CLOGGING INDICATORS** - only for spare - see section 13 and 14

<b>CID</b>	-	<b>E</b>	-	<b>05</b>	-	<b>M</b>	/	*	/	*	
Spare differential clogging indicator for in line filter								Series number		Seals material: - = NBR <b>PE</b> = FKM	
<b>Type of indicator:</b>											
<b>E</b> = electrical <b>V</b> = visual <b>T</b> = thermostated (available on request) <b>Z</b> = electronic transmitter (available on request)											
<b>Differential switching pressure</b> (only for CID-E and CID-V):											
<b>05</b> = 5 bar for filters with by-pass valve <b>08</b> = 8 bar for filters without by-pass valve											
		<b>Optional LED</b> - only for CID-E <b>L</b> = with LED <b>M</b> = without LED									

## 5 GENERAL CHARACTERISTICS

Assembly position / location	Vertical position with the bowl downward	
Ambient temperature range	<b>Standard</b> = -20°C ÷ +70°C <b>/PE option</b> = -20°C ÷ +70°C	
Storage temperature range	<b>Standard</b> = -20°C ÷ +80°C <b>/PE option</b> = -20°C ÷ +80°C	
Materials	Filter head	Cast iron
	Filter bowl	Carbon steel
Surface protection	Phosphatized	
Fatigue strength	min. 1 x 10 <sup>6</sup> cycles at 420 bar	
Compliance	RoHS Directive 2011/65/EU as last update by 2015/863/EU REACH Regulation (EC) n°1907/2006	

## 6 HYDRAULICS CHARACTERISTICS - based on mineral oil ISO VG 46 at 50 °C (viscosity 32mm<sup>2</sup>/s)

Filter size	FPH-10		FPH-30		
	21	22	23	24	
Ports size code					
Ports dimension SAE 6000 flange	3/4"	1"	1 1/4"	1 1/2"	
Filter length	A ÷ B		A ÷ D		
Max flow (l/min) at Δp= 1 bar Filter with by-pass <b>-R</b> (see note)	<b>F03</b>	30÷47	31÷51	63÷192	65÷200
	<b>F06</b>	47÷69	52÷82	105÷269	108÷285
	<b>F10</b>	62÷81	72÷100	168÷318	174÷340
	<b>F20</b>	79÷90	95÷115	217÷374	230÷400
Max flow (l/min) at Δp= 1 bar Filter without by-pass <b>-N</b> (see note)	<b>F03</b>	26÷43	27÷47	54÷160	55÷167
	<b>F06</b>	35÷62	38÷72	74÷218	75÷230
	<b>F10</b>	57÷75	64÷90	148÷254	153÷270
	<b>F20</b>	72÷88	86÷110	190÷345	198÷370
Max operating pressure [bar]	<b>420</b>				
Burst pressure [bar]	<b>&gt; 1260</b>				

**Note:** Max flow rates are measured with min and max filter length. In case of different conditions see section 11 for filter sizing

## 7 FILTER ELEMENTS

Material	Inorganic microfibre	
Filtration rating as per ISO16889	<b>F03</b>	$\beta_{4,5\mu\text{m}(c)} \geq 1000$
	<b>F06</b>	$\beta_{7\mu\text{m}(c)} \geq 1000$
	<b>F10</b>	$\beta_{12\mu\text{m}(c)} \geq 1000$
	<b>F20</b>	$\beta_{22\mu\text{m}(c)} \geq 1000$
Filter element collapse pressure	<b>R</b> = for filter with by-pass valve	21 bar
	<b>N</b> = for filter without by-pass valve	210 bar

## 8 SEALS AND HYDRAULIC FLUIDS - for other fluids not included in below table, consult our technical office

Seals, recommended fluid temperature	NBR seals (standard) = -25°C ÷ +100°C, with HFC hydraulic fluids = +10°C ÷ +50°C FKM seals (/PE option) = -25°C ÷ +100°C		
Recommended viscosity	15 ÷ 100 mm <sup>2</sup> /s - max allowed range 2.8 ÷ 500 mm <sup>2</sup> /s		
<b>Hydraulic fluid</b>	<b>Suitable seals type</b>	<b>Classification</b>	<b>Ref. Standard</b>
Mineral oils	NBR, FKM	HL, HLP, HLPD, HVL, HVLDP	DIN 51524
Flame resistant without water	FKM	HFDR, HFDR	ISO 12922
Flame resistant with water	NBR	HFC	

**9 BY-PASS VALVE**

**Filter with by-pass valve - version -R**

The filter with by-pass valve ① is used in combination with filter elements PSH-\*-R with collapse pressure 21 bar.

The by-pass valve allows the oil flow to by-pass the filter element in particular conditions:

- it protects the filter element from pressure peaks that could be generated, especially at the cold system start-up. In these cases the valve opens only for the instant necessary to discharge the pressure peak, limiting the quantity of oil that bypasses the filter.
- it allows the free passage of the oil flow in case of completely clogged filter element ( $\Delta p > 6$  bar).

This situation should be carefully avoided, by means of a scheduled maintenance, otherwise the contaminated oil will pass to the clean side of the filter and then it will circulate in the hydraulic system. The filter element must be replaced before the clogging condition, at this purpose the use of a differential clogging indicator CID-V (visual, option V) or CID-E (electrical, options L or M) is highly recommended.

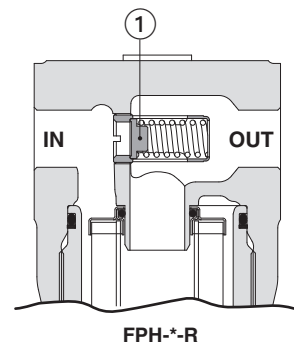

**Filter without by-pass valve - version -N**

The filter version without by-pass is recommended when the hydraulic system must be absolutely protected by contamination, then avoiding the risk that the contaminant passes through the by-pass valve.

The filter without by pass must be used in combination with filter elements PSH-N with high collapse pressure 210 bar.

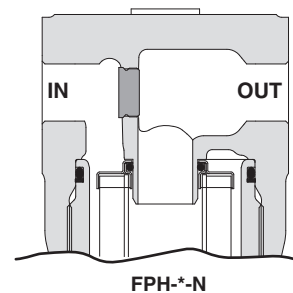

**10 BY-PASS VALVE - based on mineral oil ISO VG46 at 50°C (viscosity = 32 mm<sup>2</sup>/s)**

Q/Δp diagrams of flow through the by-pass valve

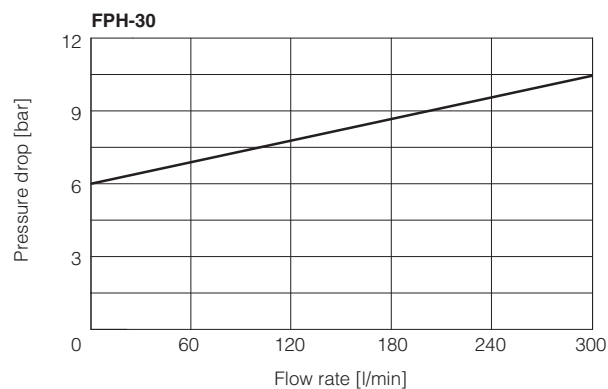
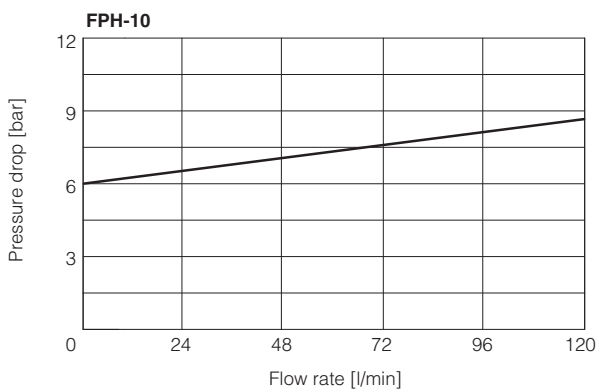



## 11 FILTERS SIZING

For the filter sizing it is necessary to consider the Total  $\Delta p$  at the maximum flow at which the filter must work.

The Total  $\Delta p$  is given by the sum of filter head  $\Delta p$  plus the filter element  $\Delta p$ :

$$\text{Total } \Delta p = \text{filter head } \Delta p + \text{filter element } \Delta p$$

In the best conditions the total  $\Delta p$  should not exceed 1,0 bar

See below sections to calculate the  $\Delta p$  of filter head and  $\Delta p$  of the filter element

### 11.1 Q/ $\Delta p$ DIAGRAMS OF FILTER HEAD

The pressure drop of filter head mainly depends on the ports size and fluid density

In the following diagrams are reported the  $\Delta p$  characteristics of filter head based on mineral oil with density 0,86 kg/dm<sup>3</sup> and viscosity 30 mm<sup>2</sup>/s

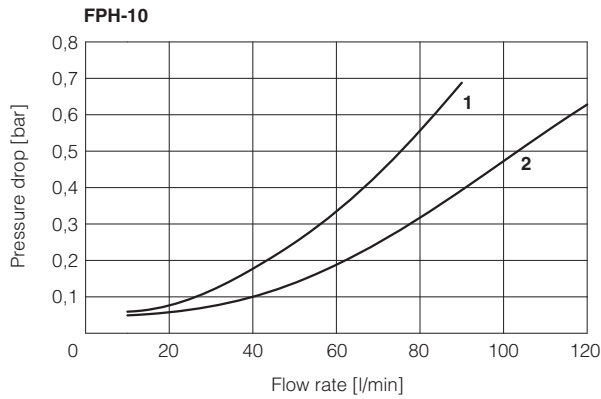

1 = FPH-10\*\*\* 21 (3/4" SAE 6000)

2 = FPH-10\*\*\* 22 (1" SAE 6000)

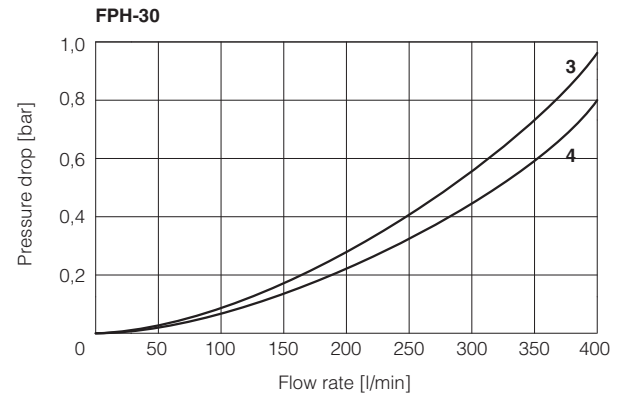

3 = FPH-30\*\*\* 23 (1 1/4" SAE 6000)

4 = FPH-30\*\*\* 24 (G 1 1/2" SAE 6000)

### 11.2 FILTER ELEMENT $\Delta p$

The pressure drop through the filter depends to:

- size of filter element
- filtration rating
- fluid viscosity

The  $\Delta p$  of filter element is given by the formula:

$$\Delta p \text{ of filter element} = Q \times \frac{Gc}{1000} \times \frac{\text{Viscosity}}{30}$$

**Q** = working flow (l/min)

**Gc** = Gradient coefficient (mbar/(l/min)). The Gc values are reported in the following table

**Viscosity** = effective fluid viscosity in the working conditions ( mm<sup>2</sup>/s)

#### Gradient coefficient Gc of PSH filter elements

Filter element size		10		30			
Filter element lenght		A	B	A	B	C	D
Filter element type	Filtration rating	Gc Gradient coefficient					
R for filter with bypass valve	F03	27.75	15.25	14	7.13	4.7	3.62
	F06	15.12	7.58	8.03	3.37	2.2	1.89
	F10	9.37	4.91	4.43	2.33	1.5	1.12
	F20	5.31	3.25	2.95	1.34	0.92	0.44
N for filter without bypass valve	F03	32.2	17.32	16.48	8.13	5.5	4.71
	F06	22.38	9.41	11.88	4.18	3.28	2.91
	F10	11.2	6.27	5.27	3.45	2.36	2.15
	F20	6.81	3.71	3.70	1.60	0.86	0.78

#### Example:

calculation of Total  $\Delta p$  for filter type FPH-30-C-F06-04-R at Q = 200 l/min and viscosity 46 mm<sup>2</sup>/s (filter element PSH-30-C-F06-R)

$\Delta p$  of filter head + filter bowl = 0,22 bar

**Gc** = 2,2 mbar/(l/min)

$$\text{Filter element } \Delta p = 200 \times \frac{2,2}{1000} \times \frac{46}{30} = 0,68 \text{ bar}$$

**Total  $\Delta p$  = 0,22 + 0,68 = 0,90 bar**

### FPH -10

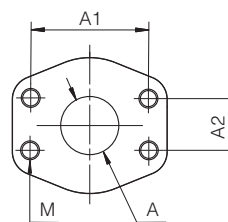
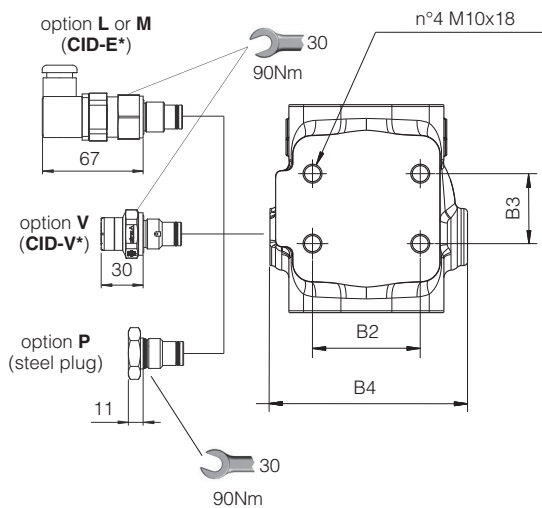
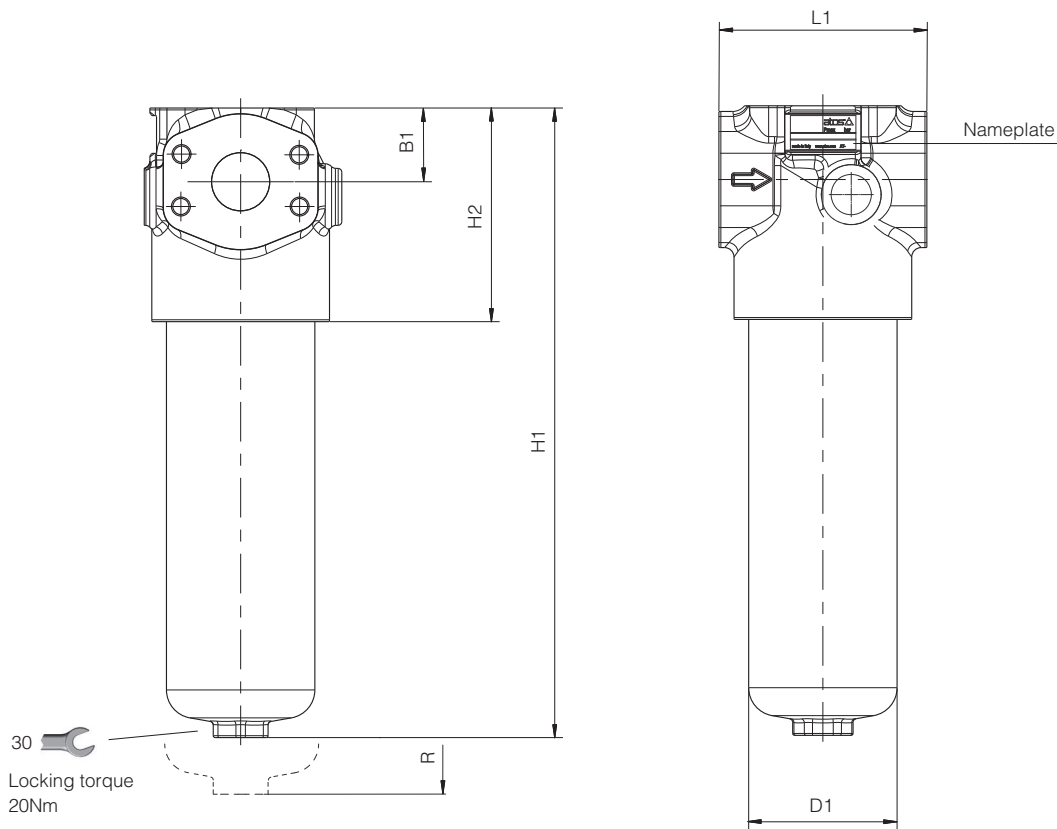

SAE J518-6000 FLANGE	A	A1	A2	M
3/4"	19	50.8	23.8	M10
1"	22	57.2	27.8	M12

Code	B1	B2	B3	B4	D1	D2	F	H1	H2	L1	R (element removal)	Mass (Kg)
FPH-10-A	39	57	37	105	78,5	-	68	222	113	110	130	6,7
FPH-10-B								333				8,4

# FPH -30

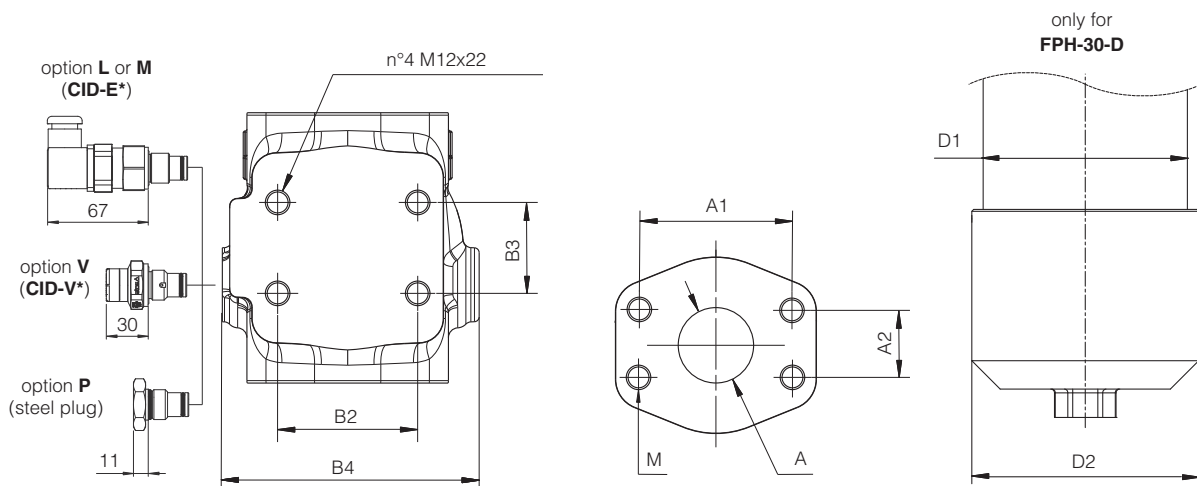
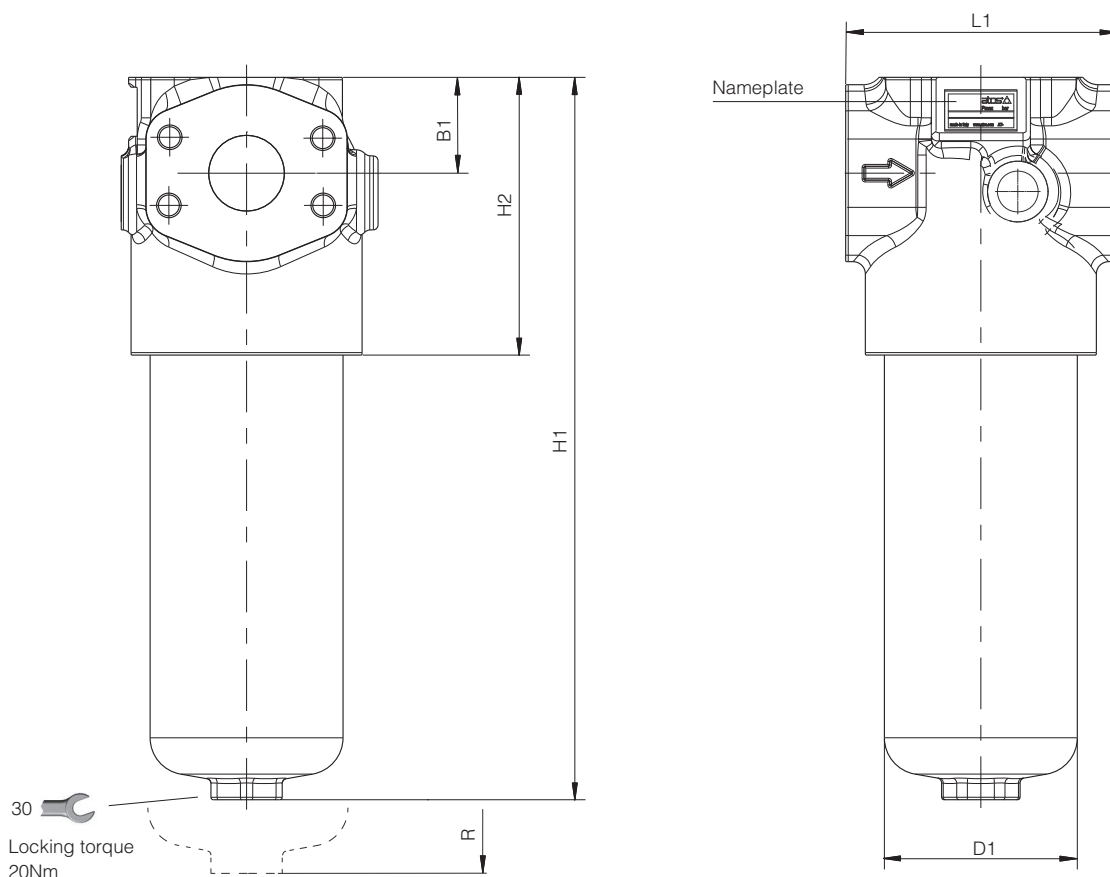

SAE J518-6000 FLANGE	A	A1	A2	M
1 1/4"	32	66.7	31.8	M14
1 1/2"	38	79.4	36.5	M16

Code	B1	B2	B3	B4	D1	D2	F	H1	H2	L1	R (element removal)	Mass (Kg)
FPH-30-A	47	76	64	140	107	-	68	262	145	140	140	13,2
FPH-30-B								355				15,5
FPH-30-C								475				18,4
FPH-30-D								568				22,8

**13 CHARACTERISTICS OF DIFFERENTIAL CLOGGING INDICATORS**

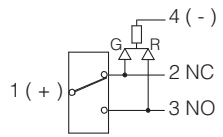
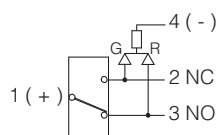
Model code	CID-E* ELECTRICAL		CID-V* VISUAL
Differential switching pressure	CID-E05, CID-V05	5 bar ± 10%	5 bar ± 15%
	CID-E08, CID-V08	8 bar ± 10%	8 bar ± 10%
Max pressure	450 bar		420 bar
Max differential pressure	200 bar		
Ambient temperature	-25°C ÷ +100°C		-25°C ÷ +80°C
Hydraulic connection	M20x1,5		
Duty factor	100%		
Mechanical life	1 x 10 <sup>6</sup> operations		
Mass (Kg)	0,16		0,11
Electric connection	Electric plug connection as per DIN 43650 with cable gland type PG7		-
Power supply	CID-E05-L, CID-E08-L	24 V <sub>DC</sub> ± 10%	
	CID-E05-M, CID-E08-M	14 V <sub>DC</sub> ÷ 30 V <sub>DC</sub>	125 V <sub>AC</sub> ÷ 250 V <sub>AC</sub>
Max current - resistive (inductive)	5 A (4 A) ÷ 4 A (3 A)	5 A (3 A) ÷ 3 A (2 A)	-
Protection degree to DIN EN 60529	IP65 with mating connector		-
Switching scheme	<b>CID-*L</b>	<b>CID-*M</b>	GREEN
	clean filter element		
Switching scheme	<b>CID-*L</b>	<b>CID-*M</b>	RED
	clogged filter element		

**14 DIMENSIONS OF DIFFERENTIAL CLOGGING INDICATORS**

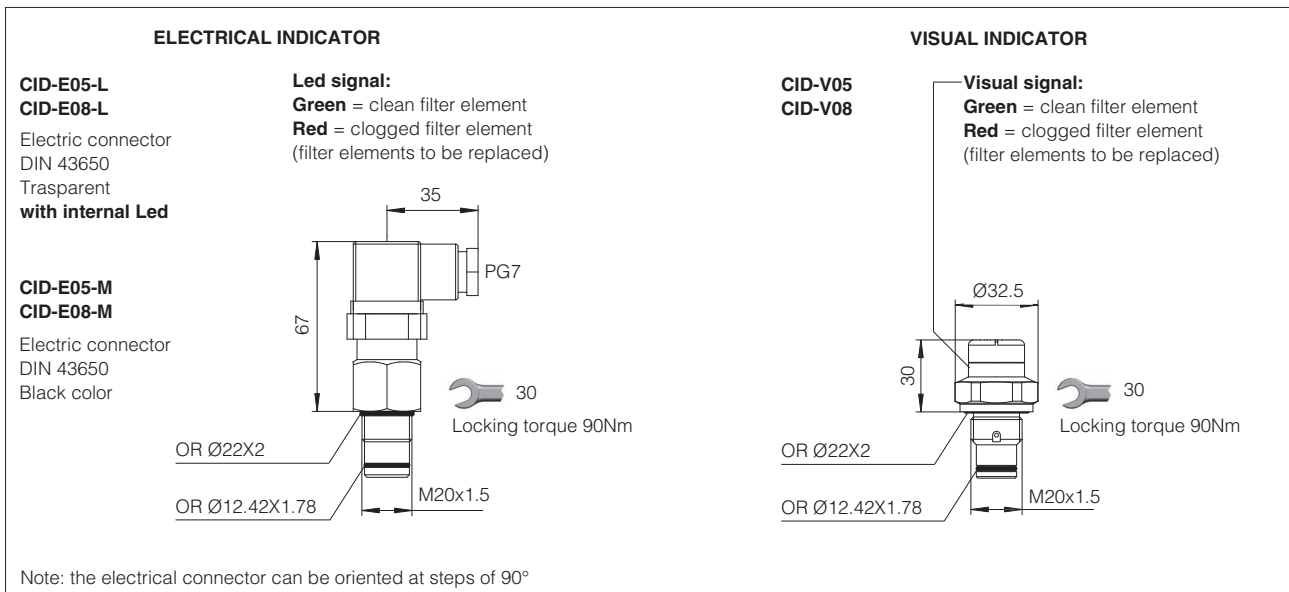

**NOTE:** Differential thermostated indicator CID-T and differential electronic transmitter CID-Z are available on request

## 15 INSTALLATION AND COMMISSIONING

The max operating pressure of the system must not exceed the max working pressure of the filter.  
 During the filter installation, pay attention to respect the flow direction, shown by the arrow on the filter head.  
 The filter should be preferably mounted with the housing downward.  
 The filter should be properly secured using the threaded fixing holes on the filter head.  
 Make sure that there is enough space for the replacement of the filter element.  
 Never run the system without the filter element.  
 For filters ordered with clogging indicator:  
 • remove the plastic plug from the indicator port on the filter head  
 • install the clogging indicator and lock it at the specified torque  
 During the cold start up (fluid temperature lower than 30°C), a false clogging indicator signal can be given due to the high fluid viscosity.

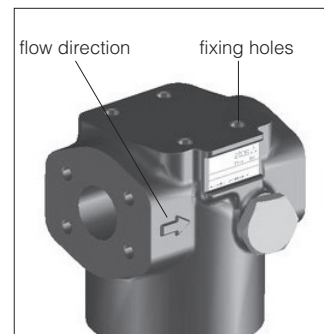

## 16 MAINTENANCE

The filter element must be replaced as soon as the clogging indicator switches to highlight the filter clogged condition.  
 For filters without clogging indicator, the filter element must be replaced according to the system manufacturer's recommendations.  
 Select the new filter element according to the model code reported on the filter nameplate, see section 14.1

For the replacement of the filter element, proceed as follow:

- releases the system pressure; the filter has no pressure bleeding device
- pay attention to the fluid and filter surface temperature. Always use suitable gloves and protection glasses
- unscrew the bowl ② from the filter head ① by turning counterclockwise (view from bottom side)
- remove the dirty filter element ③ pulling it carefully
- lubricate the seal of new filter element and insert it over the spigot in the filter head
- clean the bowl internally, lubricate the threads and screw by hand the bowl to the filter head by turning clockwise (view from bottom side). Tighten at the recommended torque.



**WARNING:** The dirty filter elements cannot be cleaned and re-used. They are classified as "dangerous waste material", then they must be disposed of by authorized Companies, according to the local laws.

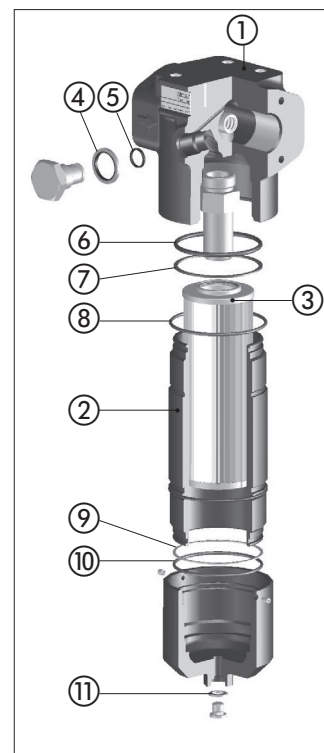

### 16.1 SEALS KIT

Filter type	Seal kit code	Seal kit composition
FPH-10	GUARN FPH-10	④+⑤+⑥+⑦+⑧
FPH-30	GUARN FPH-30	④+⑤+⑥+⑦+⑧
FPH-30-D	GUARN FPH-30-D	④+⑤+⑥+⑦+⑧+⑨+⑩+⑪

### 16.2 FILTER IDENTIFICATION NAMEPLATE



- ① Model code of complete filter
- ② Model code of filter element
- ③ Max working pressure
- ④ Filter matrix code

## 17 RELATED DOCUMENTATION

**LF010** Fluid contamination  
**LF020** Filtration guidelines



# Return line filters, tank-top type FRS

Threaded ports

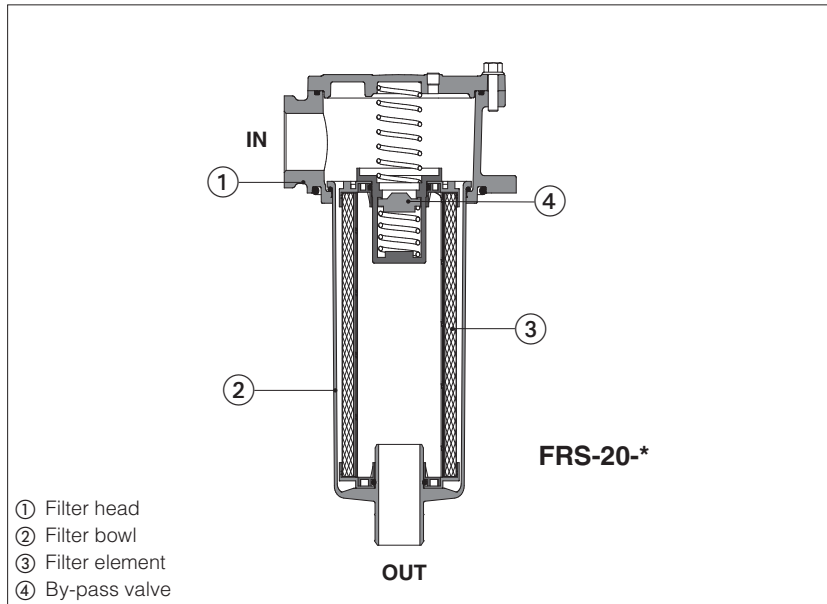

## FRS

Return filters are designed to ensure cleanliness of fluid back to the tank from contamination collected downstream of the hydraulic circuit.

They are specific for installation on the top of the hydraulic tank.

- four head sizes
- threaded ports size from G1/2" to G2" or SAE-12 to SAE-32
- by-pass valve with cracking pressure 3 bar
- high efficiency microfibre filter element with filtration rating 7 - 12 - 27  $\mu\text{m}(c)$  ( $\beta_x(c) > 1000$ , ISO 16889)
- cellulose filter elements with filtration rating 10 or 25  $\mu\text{m}$  ( $\beta_x(c) > 2$ , ISO 16889)
- without or with electrical or visual clogging indicators

Max flow **600 l/min**

Max working pressure **8 bar**

## 1 MODEL CODE OF COMPLETE FILTERS

<b>FRS</b>	-	<b>10</b>	-	<b>A</b>	-	<b>F10</b>	-	<b>00</b>	-	<b>R</b>	-	<b>W</b>	<b>**</b>	/	<b>*</b>																																			
Return line filter													Series number		Seals material: - = NBR <b>PE</b> = FKM																																			
<p><b>Filter size:</b>  <b>10</b> = ports size 1/2" ÷ 3/4"  <b>20</b> = ports size 1/2" ÷ 1 1/4"  <b>30</b> = ports size 1" ÷ 1 1/2"  <b>40</b> = ports size 1 1/4" ÷ 2"</p>																																																		
<table border="1"> <thead> <tr> <th>Filter</th> <th colspan="4">Max flow [l/min] (1)</th> </tr> <tr> <th>length:</th> <th>FRS-10</th> <th>FRS-20</th> <th>FRS-30</th> <th>FRS-40</th> </tr> </thead> <tbody> <tr> <td><b>A</b></td> <td>= 45</td> <td>65</td> <td>275</td> <td>355</td> </tr> <tr> <td><b>B</b></td> <td>= 55</td> <td>110</td> <td>300</td> <td>480</td> </tr> <tr> <td><b>C</b></td> <td>= -</td> <td>175</td> <td>-</td> <td>550</td> </tr> <tr> <td><b>D</b></td> <td>= -</td> <td>200</td> <td>-</td> <td>430 (2) (3)</td> </tr> <tr> <td><b>E</b></td> <td>= -</td> <td>-</td> <td>-</td> <td>600 (2)</td> </tr> </tbody> </table>																Filter	Max flow [l/min] (1)				length:	FRS-10	FRS-20	FRS-30	FRS-40	<b>A</b>	= 45	65	275	355	<b>B</b>	= 55	110	300	480	<b>C</b>	= -	175	-	550	<b>D</b>	= -	200	-	430 (2) (3)	<b>E</b>	= -	-	-	600 (2)
Filter	Max flow [l/min] (1)																																																	
length:	FRS-10	FRS-20	FRS-30	FRS-40																																														
<b>A</b>	= 45	65	275	355																																														
<b>B</b>	= 55	110	300	480																																														
<b>C</b>	= -	175	-	550																																														
<b>D</b>	= -	200	-	430 (2) (3)																																														
<b>E</b>	= -	-	-	600 (2)																																														
<p><b>SN</b> = only body, without filter element</p> <p><b>Microfibre filter element</b>, <math>\beta_x(c) &gt; 1000</math> - ISO 16889:  <b>F06</b> = 7 <math>\mu\text{m}</math> (c)  <b>F10</b> = 12 <math>\mu\text{m}</math> (c)  <b>F25</b> = 27 <math>\mu\text{m}</math> (c)</p> <p><b>Cellulose filter element</b>, <math>\beta_x(c) &gt; 2</math> - ISO 16889:  <b>C10</b> = 10 <math>\mu\text{m}</math> (c)  <b>C25</b> = 25 <math>\mu\text{m}</math> (c)</p>																																																		
<p><b>Clogging indicator</b> see sect. 12:</p> <p><b>W</b> = without, indicator port plugged with steel plug  <b>E</b> = electrical indicator (5)  <b>V</b> = visual indicator (5)</p>																																																		
<p><b>By-pass:</b>  <b>R</b> = by-pass valve with cracking pressure 3 bar</p>																																																		
<p><b>Ports size:</b>                  BSPP threaded:                  FRS-10      FRS-20      FRS-30      FRS-40  <b>00</b> = G 1/2"    <b>00</b> = G 1/2"    <b>02</b> = G 1"      <b>03</b> = G 1 1/4"  <b>01</b> = G 3/4"    <b>01</b> = G 3/4"    <b>03</b> = G 1 1/4"   <b>04</b> = G 1 1/2"  <b>02</b> = G 1"      <b>04</b> = G 1 1/2"   <b>05</b> = G 2"  <b>03</b> = G 1 1/4"</p> <p>SAE J1926-1 threaded (4):                  FRS-10      FRS-20      FRS-30      FRS-40  <b>41</b> = SAE-12   <b>42</b> = SAE-16   <b>44</b> = SAE-24   <b>45</b> = SAE-32                                    (3/4")            (1")                (1 1/2")        (2")</p>																																																		

**Note:** filters for use in potentially explosive atmosphere are available on request, contact Atos Technical Office

(1) Max flow rates are measured with:  $\Delta p$  0,5 bar, filter element F25, largest port size, oil viscosity 32 mm<sup>2</sup>/s - see also section 6

In case of different conditions see section 9 for filter sizing

(2) Available only for FRS-40 series 11, on request

(3) Filters type FRS-40-D is similar to FRS-40-B but it uses filter elements with smaller internal diameter

(4) Filters with SAE threaded ports are available on request

(5) The clogging indicator is supplied disassembled from the filter. The indicator port on filter head is plugged with steel plug

**2 HYDRAULIC SYMBOLS** (representation according to ISO 1219-1)

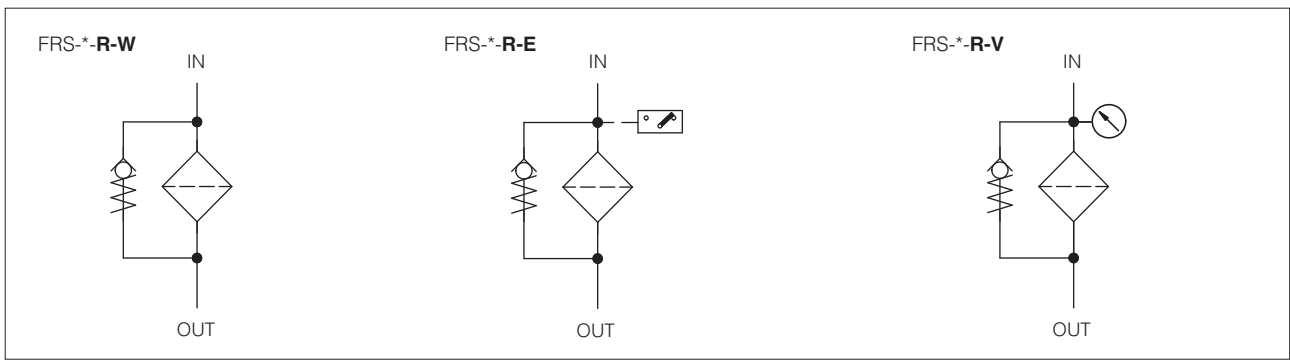

**3 MODEL CODE OF FILTER ELEMENTS** - only for spare (1)

<b>PRS</b>	-	<b>10</b>	-	<b>A</b>	-	<b>F10</b>	/	<b>**</b>	<b>*</b>																						
Spare filter element for return line filter type FRS						Series number		Seals material: - = NBR <b>PE</b> = FKM (2)																							
<p><b>Filter element size:</b></p> <p><b>10</b> = for FRS-10  <b>20</b> = for FRS-20  <b>30</b> = for FRS-30  <b>40</b> = for FRS-40</p>				<p><b>Filter element length:</b></p> <table border="0"> <tr> <td>for FRS-10</td> <td>for FRS-20</td> <td>for FRS-30</td> <td>for FRS-40</td> </tr> <tr> <td><b>A</b></td> <td><b>A</b></td> <td><b>A</b></td> <td><b>A</b></td> </tr> <tr> <td><b>B</b></td> <td><b>B</b></td> <td><b>B</b></td> <td><b>B</b></td> </tr> <tr> <td></td> <td><b>C</b></td> <td></td> <td><b>C</b></td> </tr> <tr> <td></td> <td><b>D</b></td> <td></td> <td><b>D</b></td> </tr> <tr> <td></td> <td></td> <td></td> <td><b>E</b></td> </tr> </table>		for FRS-10	for FRS-20	for FRS-30	for FRS-40	<b>A</b>	<b>A</b>	<b>A</b>	<b>A</b>	<b>B</b>	<b>B</b>	<b>B</b>	<b>B</b>		<b>C</b>		<b>C</b>		<b>D</b>		<b>D</b>				<b>E</b>	<p><b>Microfibre filter element, <math>\beta_{x(c)} &gt; 1000</math> - ISO 16889:</b></p> <p><b>F06</b> = 7 <math>\mu\text{m}</math> (c)  <b>F10</b> = 12 <math>\mu\text{m}</math> (c)  <b>F25</b> = 27 <math>\mu\text{m}</math> (c)</p> <p><b>Cellulose filter element, <math>\beta_x(c) &gt; 2</math> - ISO 16889:</b></p> <p><b>C10</b> = 10 <math>\mu\text{m}</math>  <b>C25</b> = 25 <math>\mu\text{m}</math></p>	
for FRS-10	for FRS-20	for FRS-30	for FRS-40																												
<b>A</b>	<b>A</b>	<b>A</b>	<b>A</b>																												
<b>B</b>	<b>B</b>	<b>B</b>	<b>B</b>																												
	<b>C</b>		<b>C</b>																												
	<b>D</b>		<b>D</b>																												
			<b>E</b>																												

(1) Select the filter element according to the model code reported on the filter nameplate, see section 14.1  
 (2) Filters with FKM seals are available on request  
 note: the spare filter element includes the by-pass valve

**4 MODEL CODE OF CLOGGING INDICATORS** - only for spare - see section 13 and 14

<b>CIA</b>	-	<b>V</b>	<b>**</b>
Clogging indicator for return line filter type FRS		Series number	
		<p><b>Type of indicator:</b></p> <p><b>E</b> = Electrical - pressure switch, switching pressure 2 bar  <b>V</b> = Visual - pressure gauge, range 0 ÷ 10 bar (1)</p>	

(1) Visual clogging indicator with rear side connection **CIA-V/P** available on request

**5 GENERAL CHARACTERISTICS**

Assembly position / location	Vertical position with the bowl downward
Ambient temperature range	<b>Standard</b> = -20°C ÷ +70°C / <b>PE</b> option = -20°C ÷ +70°C
Storage temperature range	<b>Standard</b> = -20°C ÷ +80°C / <b>PE</b> option = -20°C ÷ +80°C
Materials	Filter head: Aluminium alloy
	Filter bowl: Nylon PA6 reinforced (FRS-10, FRS-20, FRS-30) Steel (FRS-40 series 10), nylon PA6 reinforced (FRS-40 series 11)
Compliance	RoHS Directive 2011/65/EU as last update by 2015/863/EU REACH Regulation (EC) n°1907/2006



## 6 HYDRAULICS CHARACTERISTICS

### FRS-10, FRS-20

Filter size	10			20				
Port size code	00	01	41	00	01	02	42	03
Ports dimension	G1/2"	G3/4"	SAE 12	G1/2"	G3/4"	G1"	SAE 16	G1 1/4"
Filter length	A ÷ B			A ÷ D				
Max flow at $\Delta p$ 0,5 bar (l/min) -see note-	<b>F06</b>	13÷17	13÷17	30÷90	31÷95	31÷122		32÷123
	<b>F10</b>	24÷42	25÷44	40÷110	43÷118	44÷176		45÷180
	<b>F25</b>	40÷50	45÷55	56÷114	61÷127	65÷200		70÷210
	<b>C10</b>	70÷87	76÷97	75÷130	90÷146	92÷263		113÷277
	<b>C25</b>	75÷94	82÷105	85÷140	115÷163	118÷300		168÷300
Max operating pressure	8 bar							
Direction of filtration	See the arrow on the filter head							

### FRS-30, FRS-40

Filter size	30				40			
Port size code	02	03	04	44	03	04	05	45
Ports dimension	G1"	G1 1/4"	G1 1/2"	SAE 24	G1 1/4"	G1 1/2"	G2"	SAE 32
Filter length	A ÷ B				A ÷ E			
Max flow at $\Delta p$ 0,5 bar (l/min) -see note-	<b>F06</b>	150÷165	162÷172	166÷176	187÷430	191÷480	194÷500	
	<b>F10</b>	210÷240	230÷256	238÷266	283÷540	295÷600	303÷600	
	<b>F25</b>	240÷270	271÷293	275÷300	336÷585	354÷600 <b>(1)</b>	355÷600 <b>(1)</b>	
	<b>C10</b>	270÷290	311÷315	326÷330	365÷600 <b>(1)</b>	387÷600 <b>(1)</b>	400÷600 <b>(1)</b>	
	<b>C25</b>	330÷355	380÷390	400÷409	473÷600 <b>(1)</b>	514÷600 <b>(1)</b>	536÷600 <b>(1)</b>	
Max operating pressure	8 bar							
Direction of filtration	See the arrow on the filter head							

**Note:** Max flow rates are measured with min and max filter length. In case of different conditions see section 11

**(1)** Max flow limited by the max flow speed allowed in connecting pipes.

## 7 FILTER ELEMENTS

Material	Inorganic microfibre		Cellulose
Filtration rating as per ISO 16889	<b>F06</b>	$\beta_{06\mu m(c)} \geq 1000$	-
	<b>F10</b>	$\beta_{12\mu m(c)} \geq 1000$	-
	<b>F25</b>	$\beta_{27\mu m(c)} \geq 1000$	-
	<b>C10</b>	-	$\beta_{10\mu m(c)} \geq 2$
	<b>C25</b>	-	$\beta_{25\mu m(c)} \geq 2$

## 8 SEALS AND HYDRAULIC FLUIDS - for other fluids not included in below table, consult our technical office

Seals, recommended fluid temperature	NBR seals (standard) = -25°C ÷ +100°C, with HFC hydraulic fluids = +10°C ÷ +50°C FKM seals (/PE option) = -25°C ÷ +100°C		
Recommended viscosity	15 ÷ 100 mm <sup>2</sup> /s - max allowed range 2.8 ÷ 500 mm <sup>2</sup> /s		
Hydraulic fluid	Suitable seals type	Classification	Ref. Standard
Mineral oils	NBR, FKM	HL, HLP, HLPD, HVLP, HVLDP	DIN 51524
Flame resistant without water	FKM	HFDR, HFDR	ISO 12922
Flame resistant with water	NBR	HFC	

**9 FILTERS SIZING**

For the filter sizing it is necessary to consider the Total  $\Delta p$  at the maximum flow at which the filter must work.  
The Total  $\Delta p$  is given by the sum of filter head  $\Delta p$  plus filter bowl  $\Delta p$  plus the filter element  $\Delta p$ :

**Total  $\Delta p$  = filter head  $\Delta p$  + filter bowl  $\Delta p$  + filter element  $\Delta p$**

In the best conditions the total  $\Delta p$  should not exceed 0,5 bar  
See below sections to calculate the  $\Delta p$  of filter head and  $\Delta p$  of the filter element

**9.1 Q/ $\Delta p$  DIAGRAMS OF FILTER HEAD + FILTER BOWL**

The pressure drop mainly depends on the ports size and fluid density  
In the following diagrams are reported the  $\Delta p$  characteristics based on mineral oil with density 0,86 kg/dm<sup>3</sup> and viscosity 32 mm<sup>2</sup>/s

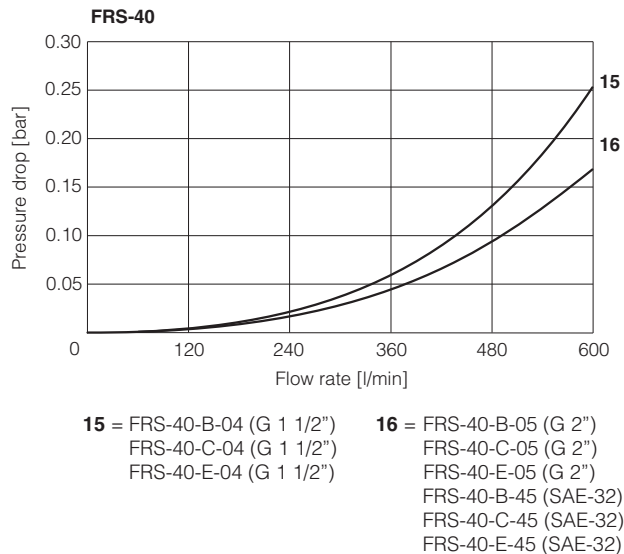
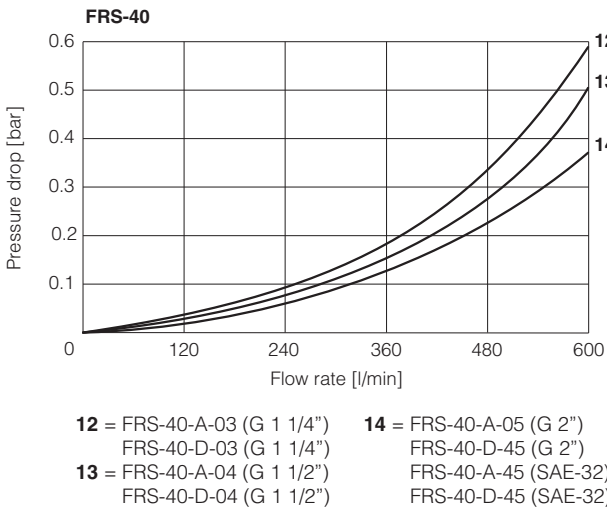
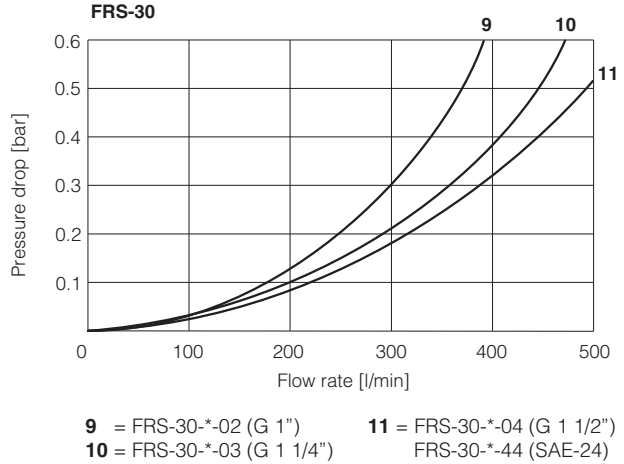
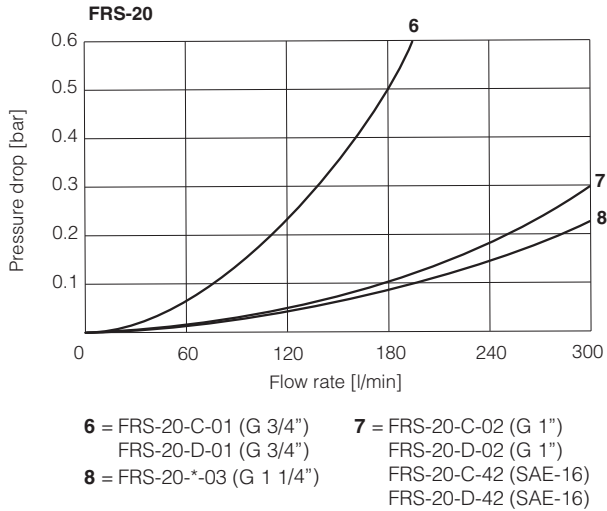
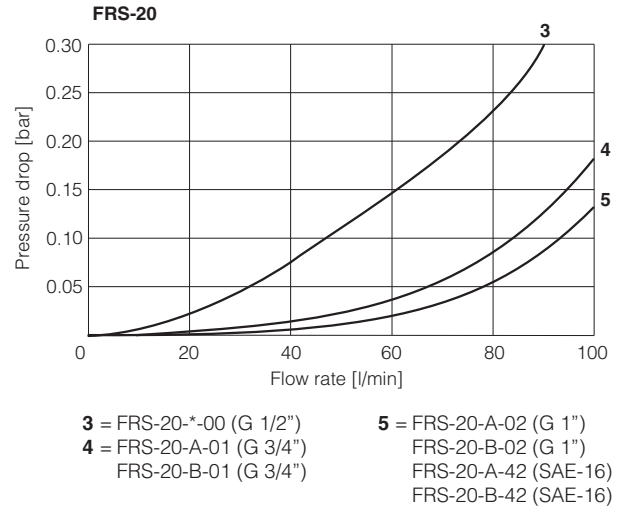
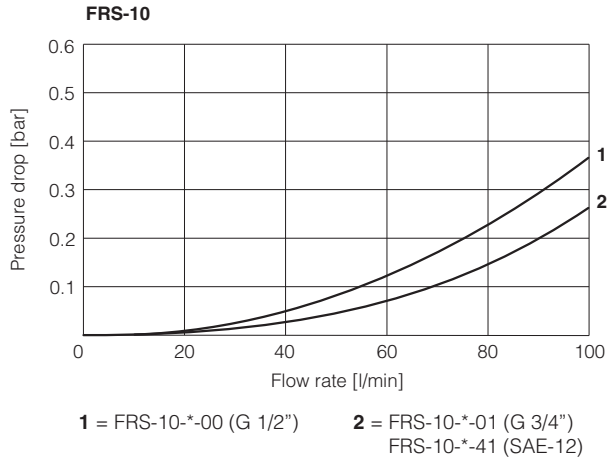

## 9.2 FILTER ELEMENT $\Delta p$

The pressure drop through the filter depends to:

- size of filter element
- filtration rating
- fluid viscosity

The  $\Delta p$  of filter element is given by the formula:

$$\Delta p \text{ of filter element} = Q \times \frac{Gc}{1000} \times \frac{\text{Viscosity}}{30}$$

**Q** = working flow (l/min)

**Gc** = Gradient coefficient (mbar/(l/min)). The Gc values are reported in the following table

**Viscosity** = effective fluid viscosity in the working conditions (mm<sup>2</sup>/s)

### Gradient coefficient Gc of FRS filter elements

Filter element size	10		20				30		40				
Filter element length	A	B	A	B	C	D	A	B	A	B	C	D	E
Filtration rating	Gc Gradient coefficient												
<b>F06</b>	37.60	28.90	15.39	8.67	5.66	3.71	2.70	2.50	2.40	1.66	1.47	2.00	0.74
<b>F10</b>	19.80	10.40	10.77	5.86	3.54	2.29	1.62	1.34	1.34	0.84	0.61	0.98	0.37
<b>F25</b>	9.22	7.18	7.14	3.92	2.25	1.88	1.19	1.00	0.98	0.52	0.43	0.71	0.25
<b>C10</b>	4.83	2.74	4.09	2.70	1.64	1.06	0.85	0.83	0.82	0.45	0.36	0.64	0.22
<b>C25</b>	4.13	2.06	2.52	1.41	0.82	0.42	0.39	0.35	0.34	0.23	0.12	0.26	0.16

#### Examples:

1) calculation of Total  $\Delta p$  for filter type FRS-20-B-F10-02-R at Q = 50 l/min and viscosity 46 mm<sup>2</sup>/s (filter element PRS-20-B-F10)

$\Delta p$  of filter head + filter bowl = 0,02 bar

**Gc** = 5,86 mbar/(l/min)

$$\text{Filter element } \Delta p = 50 \times \frac{5,86}{1000} \times \frac{46}{30} = 0,45 \text{ bar}$$

**Total  $\Delta p$  = 0,02 + 0,45 = 0,47 bar**

2) calculation of Total  $\Delta p$  of filter type FRS-40-C-F25-05-R at Q = 500 l/min and viscosity 46 mm<sup>2</sup>/s (filter element PRS-40-C-F25)

$\Delta p$  of filter head + filter bowl = 0,13 bar

**Gc** = 0,43 mbar/(l/min)

$$\text{Filter element } \Delta p = 500 \times \frac{0,43}{100} \times \frac{46}{30} = 0,33 \text{ bar}$$

**Total  $\Delta p$  = 0,13 + 0,33 = 0,46 bar**

**10 BY -PASS VALVE** - based on mineral oil ISO VG46 at 50°C (viscosity = 32 mm<sup>2</sup>/s)

Q/ $\Delta p$  diagrams of flow through the by pass valve

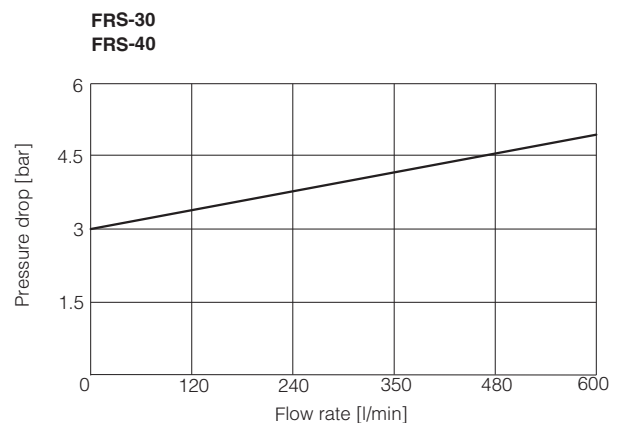
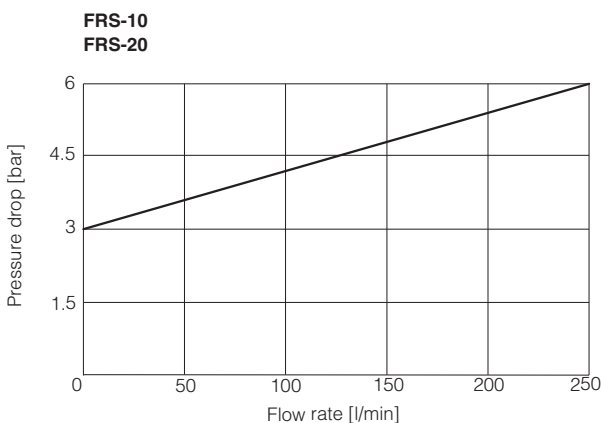

### FRS-10

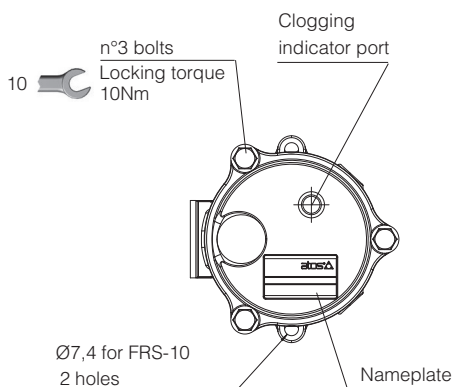
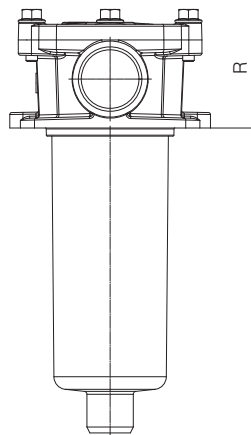
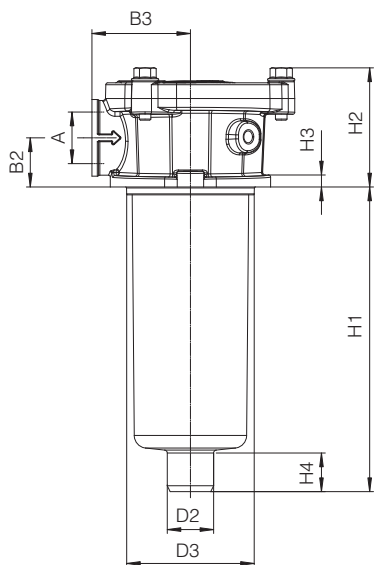

FILTER MOUNTING SURFACE

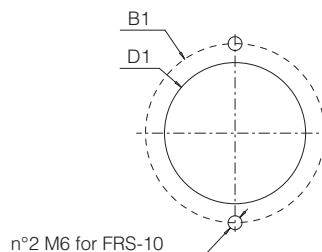

Code	A	B1	B2	B3	D1	D2	D3	H1	H2	H3	H4	R (element removal)	Mass (Kg)
FRS-10-A	1/2" BSPP	89	25	51	67,5	24	67	82	60	8	22	150	0,45
FRS-10-B	3/4" BSPP SAE-12							155					

# FRS-20

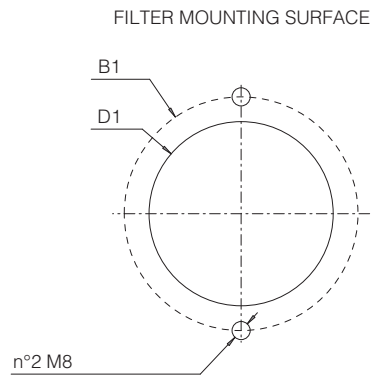
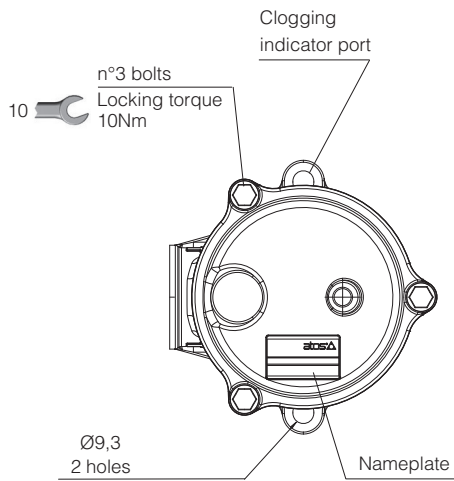
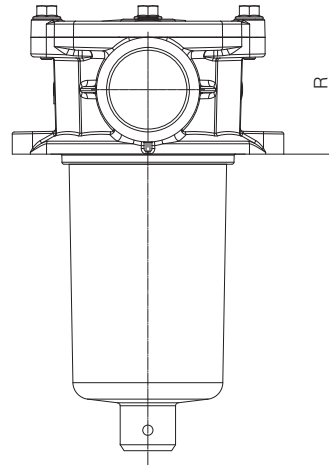
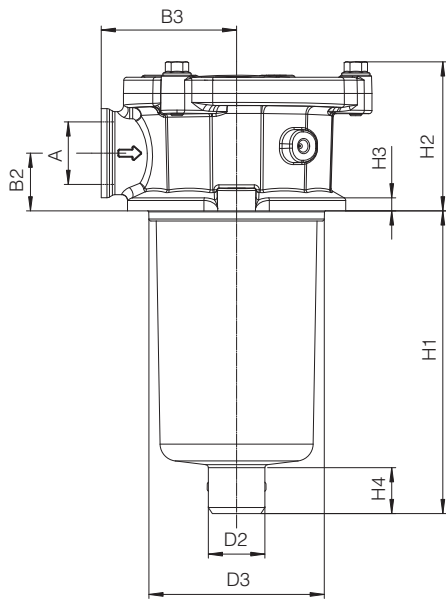

Code	A	B1	B2	B3	D1	D2	D3	H1	H2	H3	H4	R (element removal)	Mass (Kg)
FRS-20-A	1/2" BSPP	115	28,5	67	88,5	40	87	92	73	11	24	170	0,80
FRS-20-B	3/4" BSPP		(1)					139		220		0,90	
FRS-20-C	1" BSPP		32					219		295		1,10	
FRS-20-D	1 1/4" BSPP SAE-16		(2)					323		400		1,30	

(1) For port size 3/4", 1" and SAE-16

(2) For port size 1 1/4"

# FRS-30

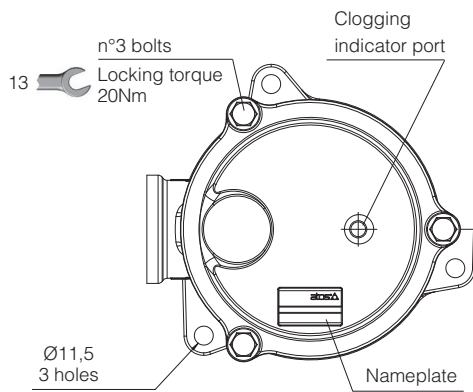
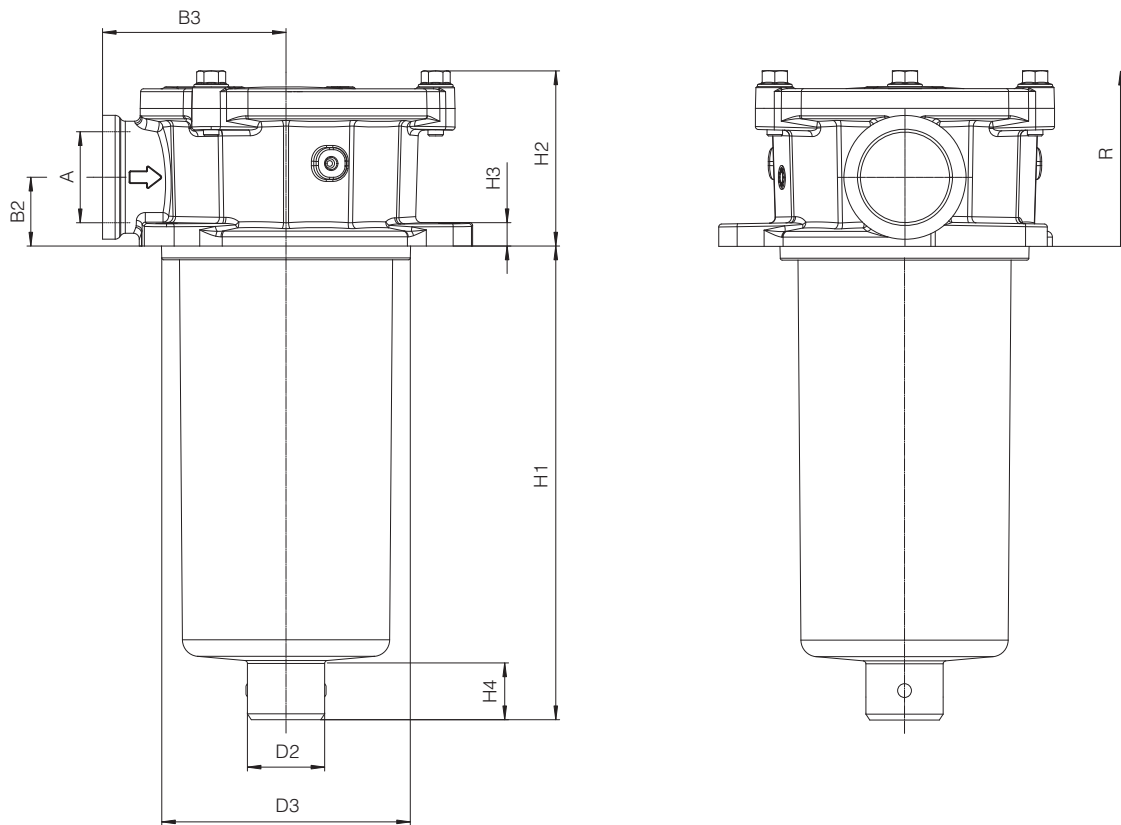

FILTER MOUNTING SURFACE

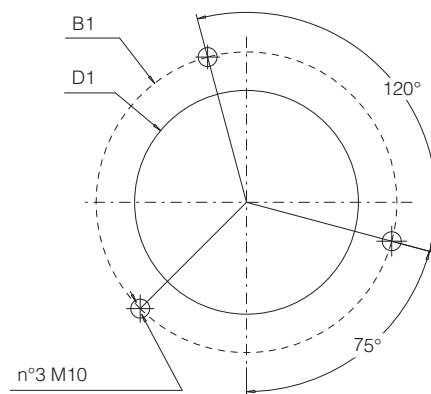

Code	A	B1	B2	B3	D1	D2	D3	H1	H2	H3	H4	R (element removal)	Mass (Kg)
FRS-30-A	1" BSPP	175	35	95	130	40	129	234	90	11	30	320	2,10
FRS-30-B	1 1/4" BSPP 1 1/2" BSPP SAE-24							263					

# FRS-40

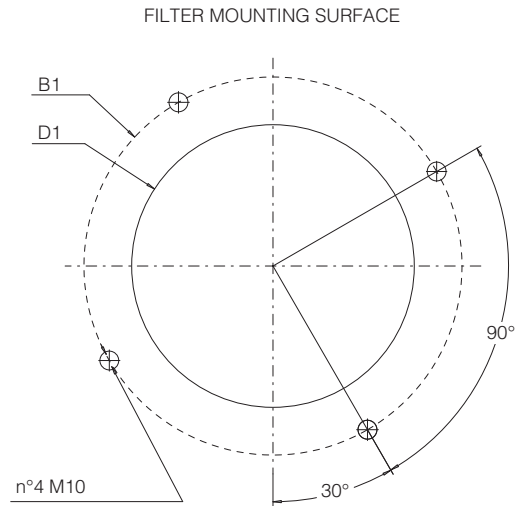
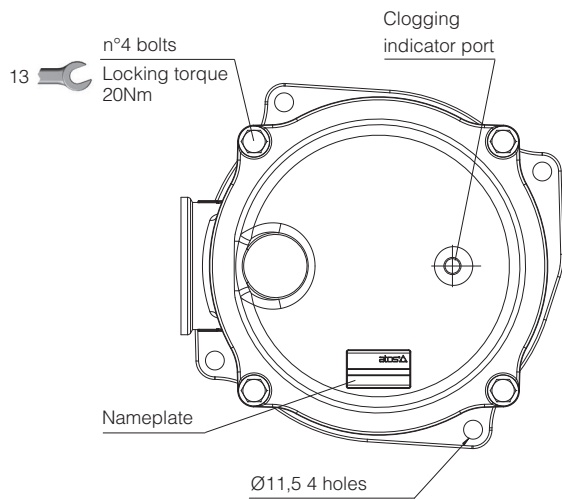
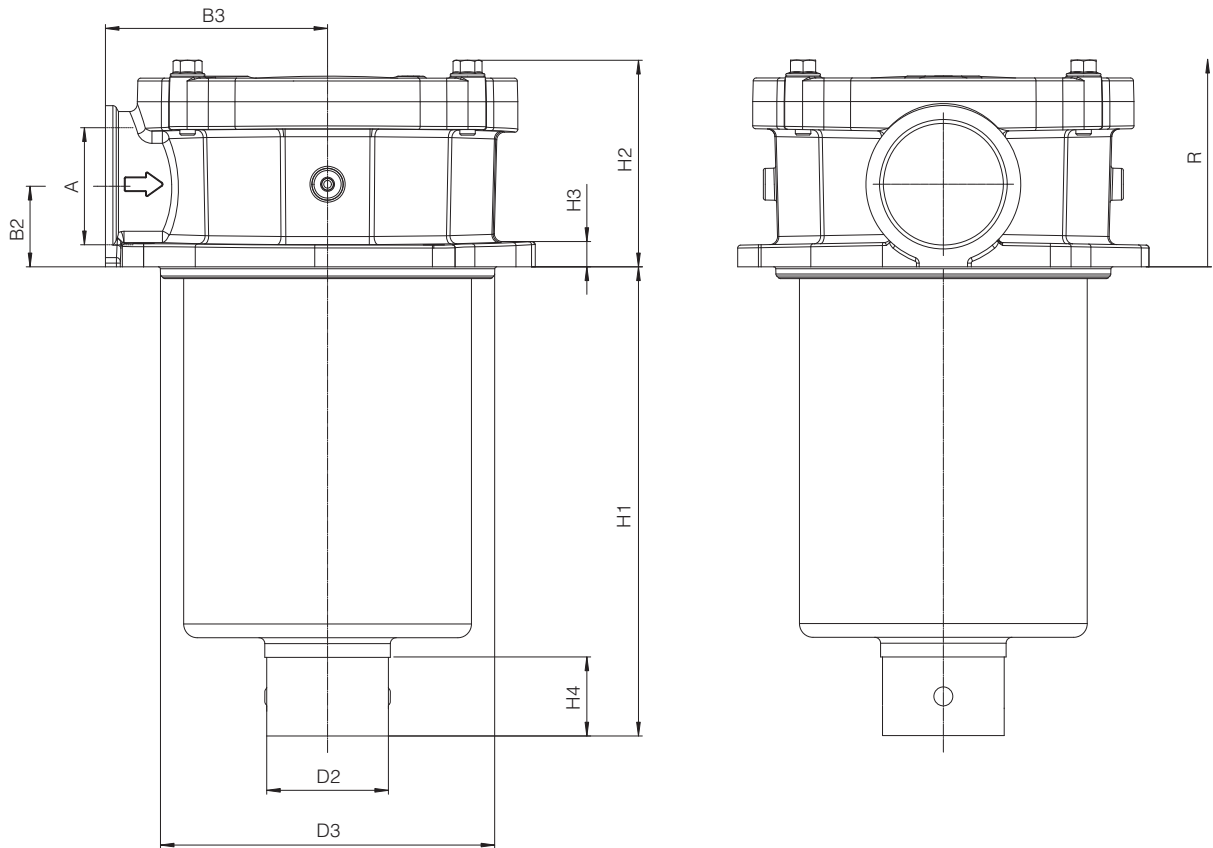

Code	A	B1	B2	B3	D1	D2		D3	H1		H2	H3	H4		R (element removal)	Mass (Kg)
						series 10	series 11		series 10	series 11			series 10	series 11		
FRS-40-A	1 1/4" BSPP 1 1/2" BSPP 2" BSPP SAE-32	220	42	115	175	50	65	174	181	165	105	11	50	37	270	3,20
FRS-40-B						240			224	330					3,60	
FRS-40-C						289			274	380					4,20	
FRS-40-D (1) (2)						-			224	330					3,60	
FRS-40-E (1)						-			424	530					4,00	

(1) Available only for series 11, on request

(2) Filter type FRS-40-D is similar to FRS-40-B but it uses filter elements with smaller internal diameter

**12 ACCESSORIES** - to be ordered separately

Following accessories can be assembled on return filters type FRS-20, FRS-30 and FRS-40 (not available for FRS-10) to avoid the foam or air/oil emulsion inside the tank caused by the return flow.

The discharge ending pipes **DSC-END\*** are used to extend the outlet port of the FRS filters below the oil level in the tank. They are available with length 250 (200 mm for FRS-40) and 500 mm

The diffusers **DIFF-FRS** are used in case of high flow rates to evenly distribute the return flow inside the tank.

They can be mounted directly on the filter bowl or using the connecting pipes **CONN-END\***, available with lengths of 250 (200 for FRS-40) and 500 mm.

**MODEL CODE OF DISCHARGE ENDING PIPES ①**

<b>DSC-END</b>	-	<b>250</b>	<b>FRS-20/30</b>
Discharge ending pipe		<b>Pipe length for FRS-20 and FRS-30:</b> 250 = 250 mm 500 = 500 mm  <b>Pipe length for FRS-40:</b> 200 = 200 mm 500 = 500 mm	<b>Filter type:</b> FRS-20/30 = for FRS-20 and FRS-30 FRS-40 = for FRS-40

**MODEL CODE OF CONNECTING ENDING PIPES ②**

<b>CONN-END</b>	-	<b>250</b>	<b>FRS-20/30</b>
Connecting ending pipe		<b>Pipe length for FRS-20 and FRS-30:</b> 250 = 250 mm  <b>Pipe length for FRS-40:</b> 200 = 200 mm (for FRS-40) 500 = 500 mm (for FRS-40)	<b>Filter type:</b> FRS-20/30 = for FRS-20 and FRS-30 FRS-40 = for FRS-40

**MODEL CODE OF DIFFUSERS ③**

<b>DIFF</b>	-	<b>FRS-20/30</b>
Diffuser		<b>Filter type:</b> FRS-20/30 = for FRS-20 and FRS-30 FRS-40 = for FRS-40

**DISCHARGE ENDING PIPE**

**CONNECTING ENDING PIPE**



**DIFFUSER**

**DIFFUSER DIMENSIONS**

DIFFUSER CODE	DIMENSIONS		
	A	B	C
DIFF-FRS-20, DIFF-FRS-30	30	45	75
DIFF-FRS-40	35	70	105

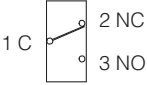

**13 CHARACTERISTICS OF CLOGGING INDICATORS**

Model code	CIA-E electrical		CIA-V visual
Switching pressure	2 bar		green sector = 0 ÷ 3 bar red sector = 3 ÷ 10 bar
Switching tolerance at 20°C	± 10% of switching pressure		-
Electric connection	Electric plug connection as per DIN 43650 with cable gland type PG7		-
Power supply	14 V <sub>DC</sub> ÷ 30 V <sub>DC</sub>	125 V <sub>AC</sub> ÷ 250 V <sub>AC</sub>	
Max current - resistive (inductive)	4 A (3 A) ÷ 3 A (2 A)	5 A (3 A) ÷ 3 A (2 A)	
Fluid temperature	-25°C ÷ +100°C		-25°C ÷ +100°C
Protection degree according to DIN 40050	IP65 with mating connector		-
Hydraulic connection	G1/8" BSP		G1/8" BSP
Duty factor	100%		100%
Mass (Kg)	0,16		0,04
Electric scheme / Hydraulic symbol	 <p>The electric scheme shows the switch position in case of clean filter element</p>		

**14 DIMENSIONS OF CLOGGING INDICATORS**

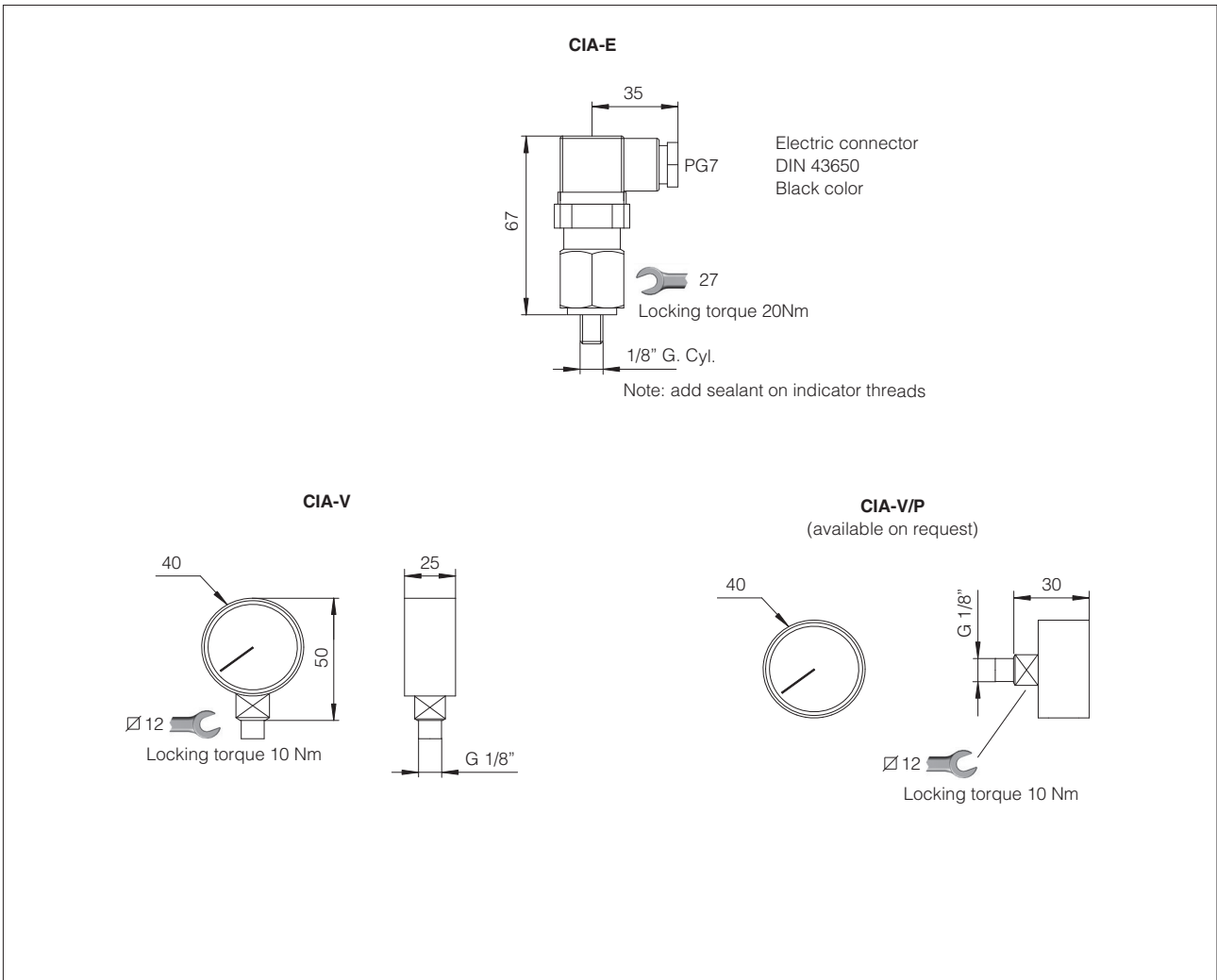

## 15 INSTALLATION AND COMMISSIONING

The tank flange with the filter mounting surface must be free of scratches.  
 During the filter installation, pay attention to respect the flow direction, shown by the arrow on the filter head.  
 Install the filter on the tank cover using the fixing holes on the filter head.  
 Connect the IN port of the filter to the system return pipe.  
 The OUT port of the filter can be connected to a pipe which length has to be properly sized so that its end remains under the oil level. See section 12 for additional discharge ending pipes.  
 Make sure that there is enough space for the replacement of the filter element.  
 Never run the system without the filter element.  
 For filters ordered with clogging indicator, code E or V:

- remove the steel plug from the indicator port on the filter head
- install the clogging indicator and lock it at the specified torque

During the cold start up (fluid temperature lower than 30°C), a false clogging indicator signal can be given due to the high fluid viscosity.

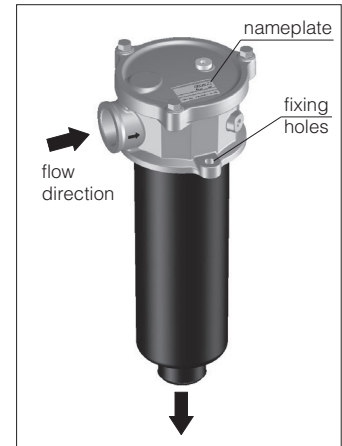

## 16 MAINTENANCE

The filter element must be replaced as soon as the clogging indicator switches to highlight the filter clogged condition  
 For filters without clogging indicator, the filter element must be replaced according to the system manufacturer's recommendations.  
 Select the new filter element according to the model code reported on the filter nameplate, see section 17.2

For the replacement of the filter element, proceed as follow:

- switch-off the system and make sure that there is no residual pressure in the filter line (i.e. pressurized tank); the filter has no pressure bleeding device
- pay attention to the fluid and filter surface temperature. Always use suitable gloves and protection glasses
- remove the cover ① from the filter head ② by releasing the bolts ③
- remove the spring ④ and the bowl ⑦
- remove the dirty filter element ⑥ pulling it upward carefully
- clean the bowl ⑦
- install the bowl ⑦ after having checked the good condition of the seal ⑧
- insert the new filter element over the spigot in the filter bowl; the filter element includes the by-pass valve ⑤
- install the spring ④
- mount the cover and lock the relevant bolts ③ after having checked the good condition of the seal ⑨

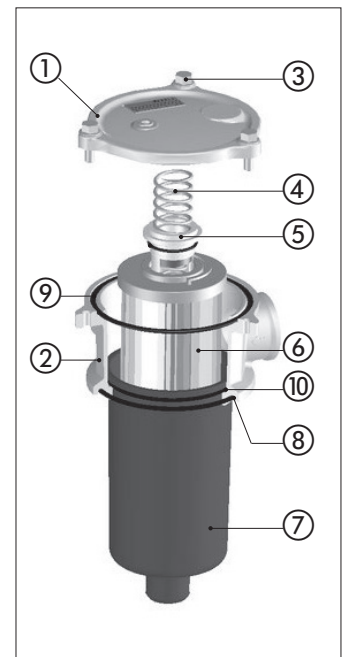

**WARNING:** The dirty filter elements cannot be cleaned and re-used. They are classified as "dangerous waste material", then they must be disposed of by authorized Companies, according to the local laws.

### 16.1 SEALS KIT

Filter type	Seal kit code
FRS-10	GUARN FRS-10 ⑧+⑨+⑩
FRS-20	GUARN FRS-20 ⑧+⑨+⑩
FRS-30	GUARN FRS-30 ⑧+⑨+⑩
FRS-40	GUARN FRS-40 ⑧+⑨+⑩

### 17.2 SPARE SPRING ④

Filter type	Seal kit code
FRS-10	MO-1246
FRS-20	MO-1247
FRS-30	MO-1248
FRS-40	MO-1249

### 16.2 FILTER IDENTIFICATION NAMEPLATE



- ① Model code of complete filter
- ② Model code of filter element
- ③ Filter matrix code

## 17 RELATED DOCUMENTATION

**LF010** Fluid contamination  
**LF020** Filtration guidelines

# Suction filters type FSS

Threaded ports

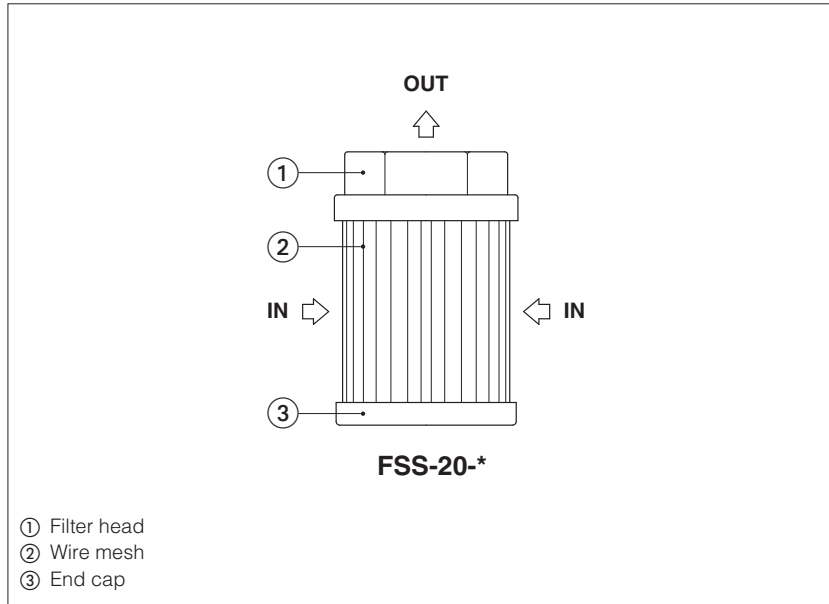

**FSS**

Suction filters are designed to protect pumps from ingestion of solid particles and coarse contamination present in the oil tank, which may cause heavy damage and seizures.

They are designed to be screwed onto the pumps suction line.

FSS filters are available with following features:

- four sizes with BSPP threaded ports, from 1/2" to 3"
- wire mesh 125 µm (c)
- version without or with by-pass valve

Max flow **450 l/min**

**1 MODEL CODE**

<b>FSS</b>	-	<b>10</b>	-	<b>A</b>	-	<b>W125</b>	-	<b>00</b>	-	<b>N</b>	-	<b>**</b>																											
Suction filter												Series number																											
<b>Filter size:</b>													<b>By-pass:</b>																										
10													N = without by-pass																										
20													R = by-pass valve, craking pressure 0,35 bar																										
30																																							
40																																							
<b>Filter length:</b>													<b>Port size:</b>																										
<b>A</b> = 20													BSPP threaded:																										
<b>B</b> = -													FSS-10-A																										
<b>C</b> = -													<b>00</b> = G 1/2"																										
<b>Max flow [l/min] (1)</b>													FSS-20-A																										
<table border="1" style="display: inline-table; border-collapse: collapse;"><thead><tr><th>Filter</th><th colspan="4">Max flow [l/min] (1)</th></tr><tr><th>length:</th><th>FSS-10</th><th>FSS-20</th><th>FSS-30</th><th>FSS-40</th></tr></thead><tbody><tr><td><b>A</b></td><td>= 20</td><td>38</td><td>85</td><td>330</td></tr><tr><td><b>B</b></td><td>= -</td><td>60</td><td>125</td><td>450</td></tr><tr><td><b>C</b></td><td>= -</td><td>-</td><td>200</td><td>-</td></tr></tbody></table>													Filter	Max flow [l/min] (1)				length:	FSS-10	FSS-20	FSS-30	FSS-40	<b>A</b>	= 20	38	85	330	<b>B</b>	= -	60	125	450	<b>C</b>	= -	-	200	-	FSS-20-B	
Filter	Max flow [l/min] (1)																																						
length:	FSS-10	FSS-20	FSS-30	FSS-40																																			
<b>A</b>	= 20	38	85	330																																			
<b>B</b>	= -	60	125	450																																			
<b>C</b>	= -	-	200	-																																			
													<b>01</b> = G 3/4"																										
													<b>02</b> = G 1"																										
													FSS-30-A																										
													<b>03</b> = G 1 1/4"																										
													FSS-30-B																										
													<b>04</b> = G 1 1/2"																										
													FSS-30-C																										
													<b>05</b> = G 2"																										
<b>Filtration rating:</b>													FSS-40-A																										
<b>W125</b> = wire mesh 125 µm													FSS-40-B																										
													<b>06</b> = G 2 1/2"																										
													<b>07</b> = G 3"																										

(1) Max flow rates are performed in following conditions:  
 - clean filter element  
 - Δp = 0,015 bar  
 - mineral oil with viscosity 32 mm²/s

In case of different conditions see Q/Δp diagrams at section 6

**2 HYDRAULIC SYMBOL** (representation according to ISO 1219-1)

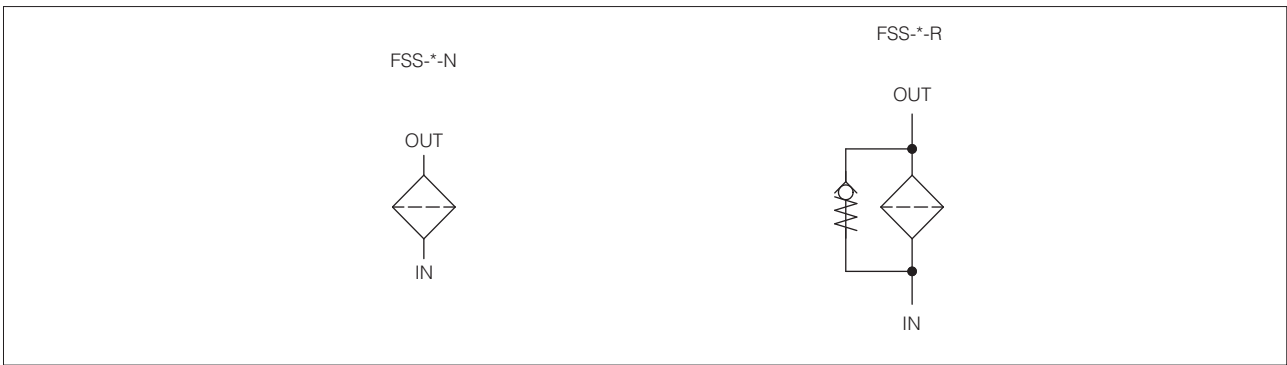

**3 GENERAL CHARACTERISTICS**

Assembly position / location	Any position	
Differential collapse pressure [bar]	1	
Ambient temperature range	-20°C ÷ +70°C	
Storage temperature range	-20°C ÷ +80°C	
Materials	Filter head	Nylon
	Filter end cap	Carbon steel, zinc plated
	Filter Mesh	Stainless steel AISI 304

**4 HYDRAULIC FLUIDS** - for other fluids not included in below table, consult our technical office

Recommended fluid temperature	-25°C ÷ +100°C, with HFC hydraulic fluids = +10°C ÷ +50°C	
Recommended viscosity	15 ÷ 100 mm <sup>2</sup> /s - max allowed range 2.8 ÷ 500 mm <sup>2</sup> /s	
<b>Hydraulic fluid</b>	<b>Classification</b>	<b>Ref. Standard</b>
Mineral oils	HL, HLP, HLPD, HVLP, HVLDP	DIN 51524
Flame resistant without water	HFDU, HFDR	ISO 12922
Flame resistant with water	HFC	

**5 BY-PASS VALVE** - version -R

The by-pass valve allows the oil flow to by-pass the suction filter when the pressure drop across the element exceeds 0,35 bar, so that to avoid the pump cavitation.

This may happens in particular conditions as:

- instantaneous high flow peaks
- filter mesh clogged by contamination

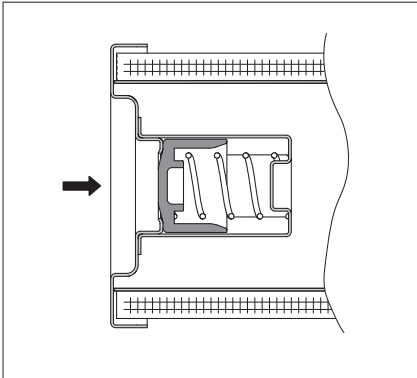

## 6 FILTER SIZING

Suction filters must be largely sized to avoid the pumps cavitation. In the best conditions the  $\Delta p$  should not exceed 0.015 bar

### 6.1 Q/ $\Delta p$ DIAGRAMS

In following diagrams are reported the  $\Delta p$  characteristics of filter based on mineral oil with density 0,86 kg/dm<sup>3</sup> and viscosity 32 mm<sup>2</sup>/s. in case of different viscosity the effective  $\Delta p_E$  is given by the formula:

$$\Delta p_E = \Delta p \times \frac{\text{viscosity}}{32}$$

$\Delta p_E$  = pressure drop calculated at the effective viscosity

$\Delta p$  = pressure drop reported in the below diagrams

Viscosity = effective fluid viscosity in the working condition (mm<sup>2</sup>/s)

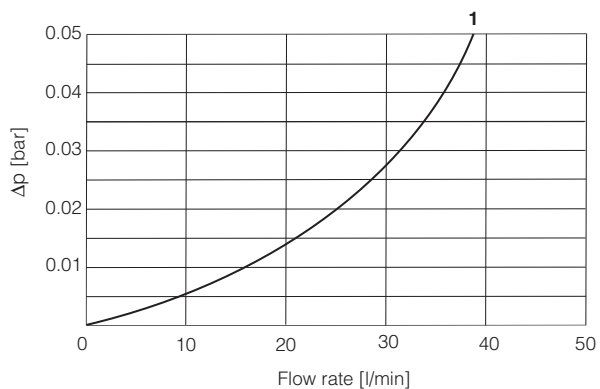

1 = FSS-10-A

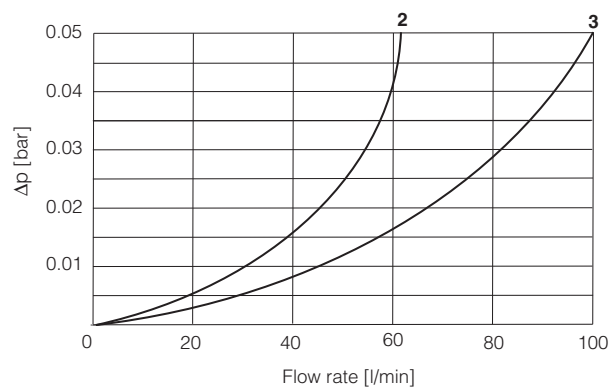

2 = FSS-20-A  
3 = FSS-20-B

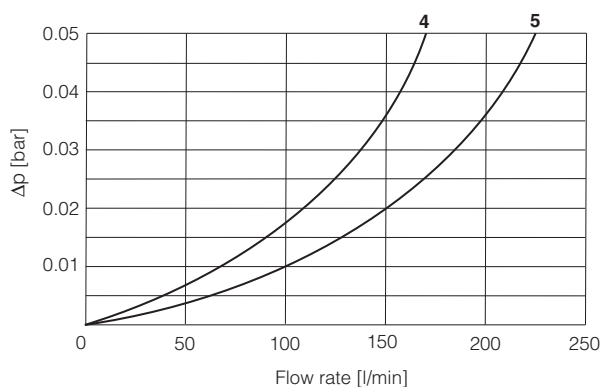

4 = FSS-30-A  
5 = FSS-30-B

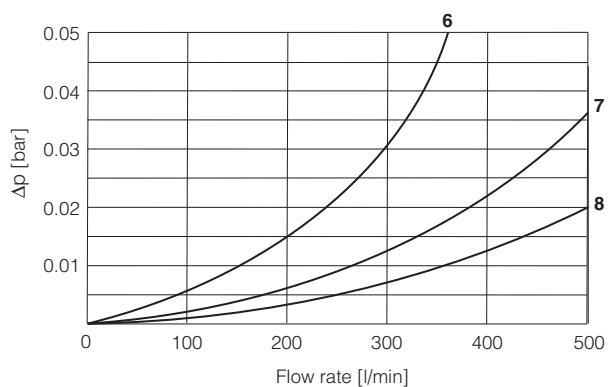

6 = FSS-30-C  
7 = FSS-40-A  
8 = FSS-40-B

## 7 INSTALLATION DIMENSIONS OF FSS FILTERS [mm]

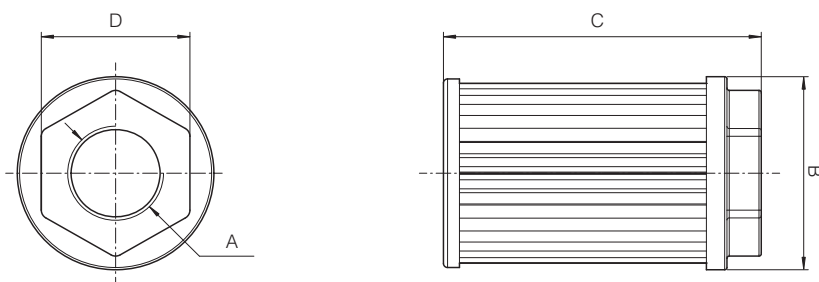

Code	A	B	C	D	Mass (Kg)
FSS-10-A	1/2" BSPP	46	106	36	0,10
FSS-20-A	3/4" BSPP	64	109	50	0,19
FSS-20-B	1" BSPP		139		0,21
FSS-30-A	1 1/4" BSPP	86	200	65	0,33
FSS-30-B	1 1/2" BSPP		260		0,24
FSS-30-C	2" BSPP		212	75	0,51
FSS-40-A	2 1/2" BSPP	150	272	110	1,07
FSS-40-B	3" BSPP		0,92		

## 8 INSTALLATION AND COMMISSIONING

The suction filters FSS must be generously sized to avoid pump cavitation. The size of the OUT port of the FSS filter must be equal to or greater than the corresponding suction port of the pump.

The SSP filter must always remain below the oil level in the tank, in any operating condition.

During installation, a minimum distance must be observed between the filter and the bottom of the tank (see figure on the side) to avoid the possibility that the contaminant deposited on the bottom is sucked up.

The SSP filter should be installed as far as possible from the return pipe. It is advisable to use separators inside the tank to keep the suction area separate from the area affected by the return flow.

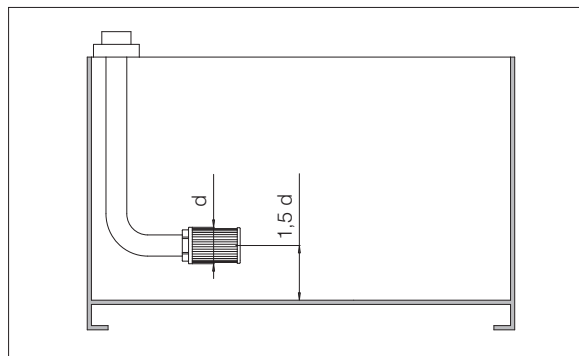

## 9 MAINTENANCE

The filter must be replaced according to the system manufacturer's recommendations.



**WARNING:** The dirty filters cannot be cleaned and re-used. They are classified as "dangerous waste material", then they must be disposed of by authorized Companies, according to the local laws.

### 9.1 FILTER IDENTIFICATION

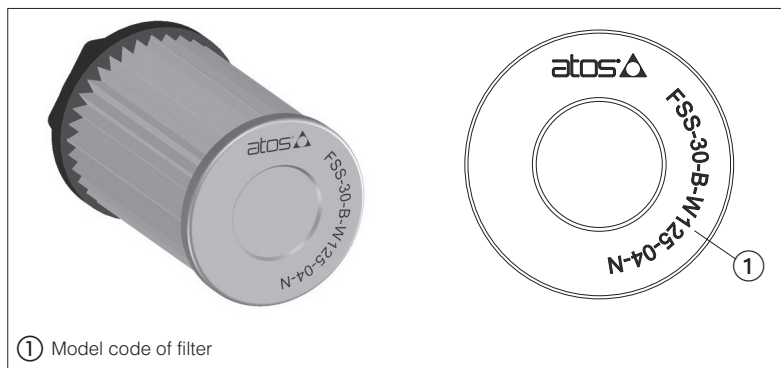

## 10 RELATED DOCUMENTATION

<b>LF010</b>	Fluid contamination
<b>LF020</b>	Filtration guidelines











atos   
the smart electrohydraulics

## Worldwide Sales Organization

A sales network with 25 branches, 120 sales professionals and distributors in more than 80 countries, together with great responsiveness and focus on customers



### Atos spa

Italy - 21018 Sesto Calende

Phone +39 0331 922078

[info@atos.com](mailto:info@atos.com)

[www.atos.com](http://www.atos.com)