

# Basic for digital proportionals with P/Q control

## 1 ABOUT DIGITAL PROPORTIONAL DRIVER with P/Q CONTROL - option S

Option **S** on digital drivers ① adds the closed loop control of pressure (**SP**) or force (**SF** and **SL**) to the basic functions of proportional directional valves flow regulation. The alternated P/Q control operates according to the two electronic reference signals by a dedicated algorithm that automatically selects which control will be active time by time. The dynamics of the switching between the two controls can be regulated thanks to specific software setting, in order to avoid instability or vibrations.

Flow regulation is active when the actual system pressure/force is lower than the relevant input reference signal - the valve works normally to regulate the flow by controlling in closed-loop the spool/poppet position through the integral LVDT transducer ②.

Pressure/force control is activated when the actual system pressure/force, measured by remote transducers ③, grows up to the relevant input reference signal - the driver reduces the valve's flow regulation in order to keep steady the system pressure/force.

If the pressure/force tends to decrease under its input reference signal, the flow control returns active (see section 2).

The dynamic response of pressure/force control can be adapted to different system's characteristics, by setting the internal PID parameters using Atos PC software. Up to 4 different PIDs are selectable to optimize the system dynamic response according to different hydraulic working conditions.

**Note:** alternated P/Q control is also available for digital servoproportionals with integral axis controller; please refer tech table **FS230**

### SP - Pressure Control - 1 pressure transducer

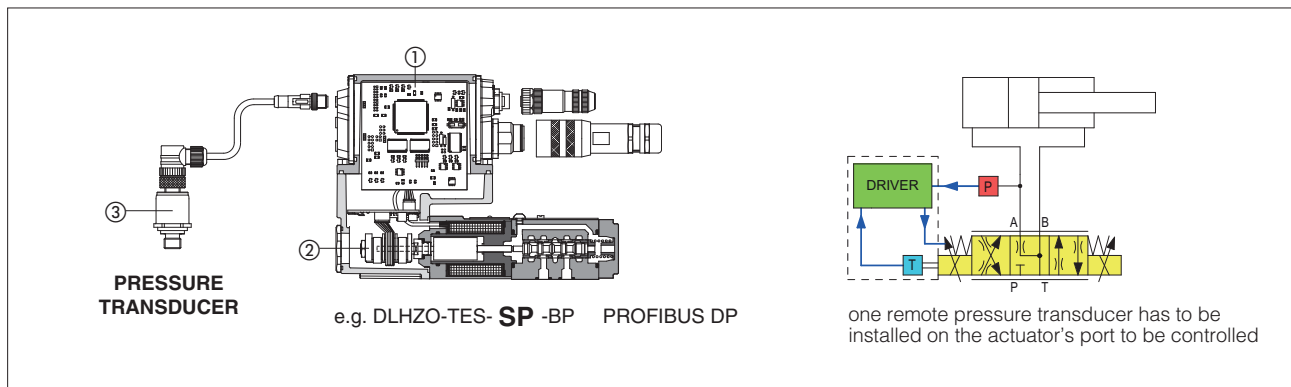

### SF - Force Control - 2 pressure transducers

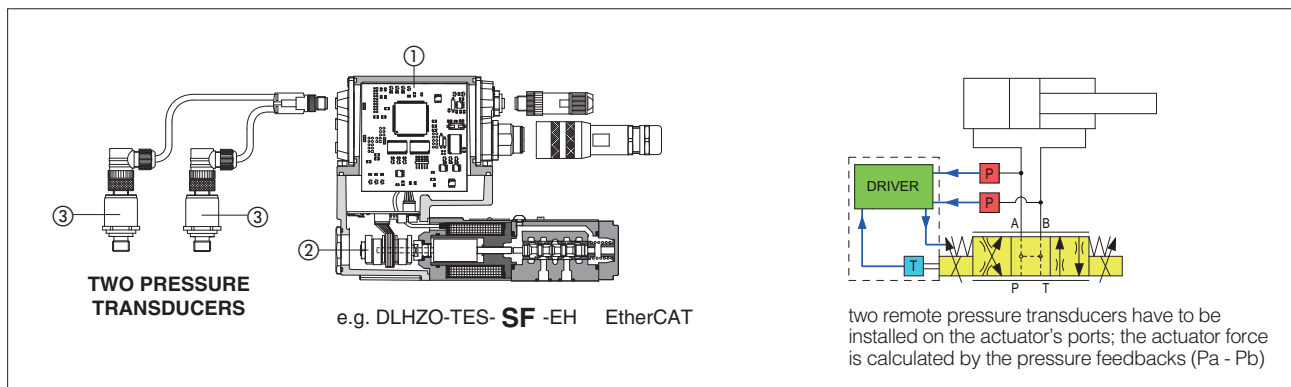

### SL - Force Control - 1 load cell

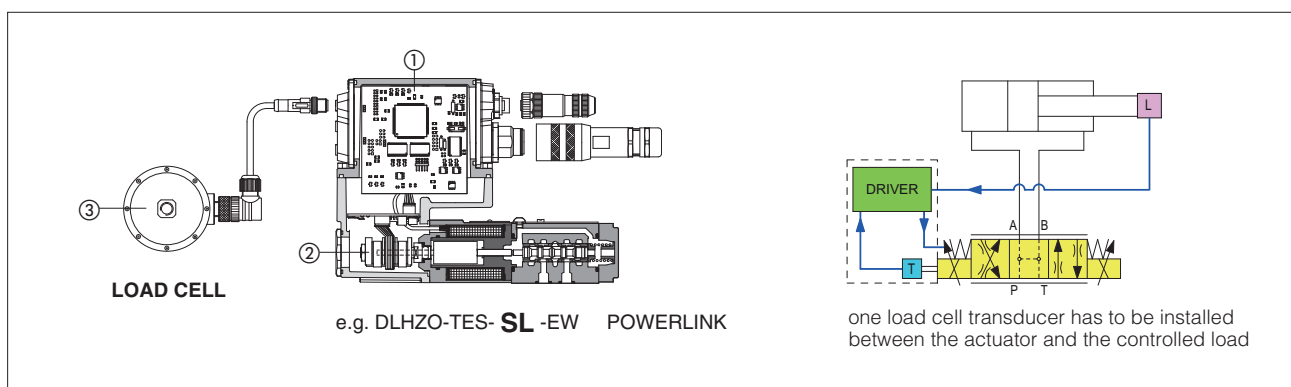

## 2 P/Q CONTROLS APPLICATION EXAMPLES

The following applications examples are intended just as generic reference of the possible configurations with the digital integral electronics with option **S**. Alternated P/Q control is factory preset according to selected valve code and can be reconfigured via software selecting between **SP**, **SF**, **SL**.

Please contact Atos technical department for additional evaluations related to specific applications usage.

### 2.1 High-dynamic pressure reducing controls - only for SP

3 way or 4 way directional proportional valves with SP control, in subplate mounting or cartridge execution, are operated in 3-way hydraulic configuration to obtain high-dynamic pressure reducing control on the A user port:

- flow reference signal is used to limit the maximum flow during the pressure regulation
- pressure reference signal is used to regulate the pressure on the valve's A user port; the rapid/repeatable response of the pressure control is performed in high dynamics by the directional valve's closed loop regulation

#### Requirements:

- a remote pressure transducer has to be installed in the hydraulic system on the controlled user port (when using 4 way valves either A or B port can be used while the not controlled port must be plugged)
- zero overlap spool and valve without fail safe position are recommended; positive overlap valves with PABT ports closed in central position has not to be used

### High-dynamic - only for SP

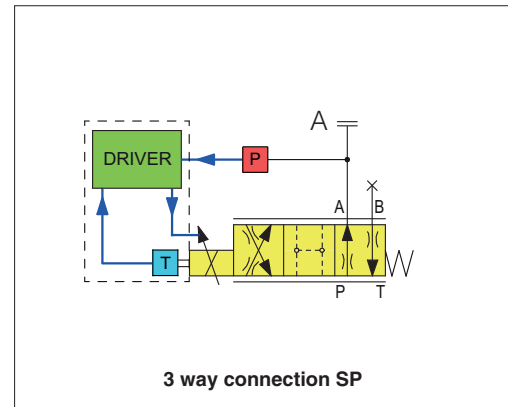

### 2.2 Single effect actuators with speed/pressure/force controls - only for SP or SL

3 way or 4 way directional proportional valves with SP or SL control, in subplate mounting or cartridge execution, are operated in 3-way hydraulic configuration to control speed/pressure (force) on single effect actuators:

- flow reference signal is used to regulate the actuator's forward and backward speed while pressure (force) reference signal is used to limit the maximum pushing pressure (force) to the actuator

or

- pressure (force) reference signal is used to regulate the actuator pushing pressure (force) while flow reference signal is used to limit the maximum actuator speed

#### Requirements:

- for SP a remote pressure transducer has to be installed in the hydraulic system on the actuator pushing port (when using 4 way valves either A or B port can be used while the not controlled port must be plugged)
- for SL a remote force transducer has to be installed between the actuator and the controlled load
- zero overlap spool is recommended; positive overlap valves with PABT ports closed in central position has not to be used

### Single effect - only for SP or SL

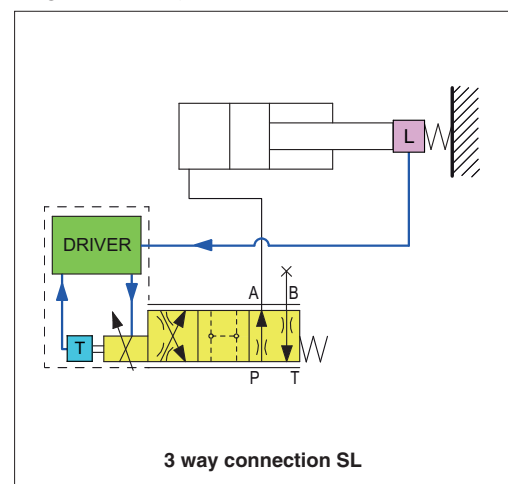

### 2.3 Double effect actuators with speed/pressure controls - only for SP

4 way directional proportional valves with SP control, in subplate mounting execution, control speed/pressure on double effect actuators:

- flow reference signal is used to regulate the actuator's forward and backward speed while pressure reference signal is used to limit the maximum pushing pressure to the actuator

or

- pressure reference signal is used to regulate the actuator pushing pressure while flow reference signal is used to limit the maximum forward and backward actuator speed

#### Requirements:

- a remote pressure transducer has to be installed on the actuator's pushing port
- dedicated spool with strong "meter-in" characteristic in central position has to be used; during depressurizing phases the not controlled port remains at zero pressure (T port connection) - see section [3](#)

### Double effect - only for SP

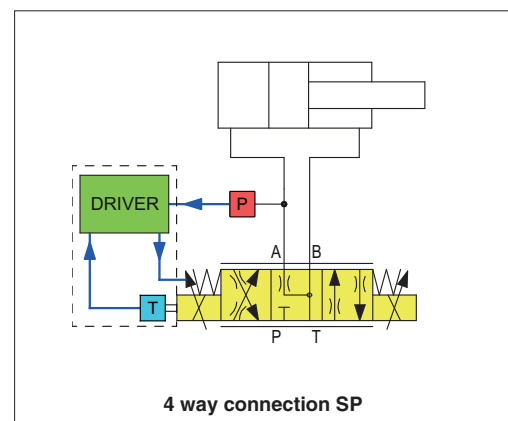

## 2.4 Double effect actuators with force limit/regulation - only for SF or SL

4 way directional proportional valves with SF or SL control, in subplate mounting execution, control speed/force on double effect actuators:

- flow reference signal is used to regulate the actuator's forward and backward speed while force reference signal is used to limit the maximum pushing and pulling force to the actuator
- or
- force reference signal is used to regulate the actuator pushing and pulling force while flow reference signal is used to limit the maximum actuator speed

### Requirements:

- for SF two remote pressure transducers have to be installed on the both actuator's ports
- for SL one push/pull load cell transducer has to be installed between the actuator and the controlled load
- zero overlap spool is recommended; positive overlap valves with PABT ports closed in central position has not to be used

### Advantages:

- force control is possible in both push and pull directions
- SL allows a more precise force control despite of a more complex installation of the load cell transducer
- SF allows to add force control also into existing systems thanks to the simple installation of pressure transducers

### Control modes:

- Flow priority: flow reference signal is used to move forward and backward the actuator while force is limited/regulated in both push and pull direction
- Force priority: force reference signal is used to control both push and pull forces while flow is limited/regulated in both direction

### Notes:

- servoproportional type DLHZO, DLKZOR and DPZO-L are strongly recommended for high accuracy applications, see tech table **FS180, FS178**
- auxiliary check valves are recommended in case of specific hydraulic configuration requirements in absence of power supply or fault, see tech table **EY100**

## Double effect - only for SF or SL

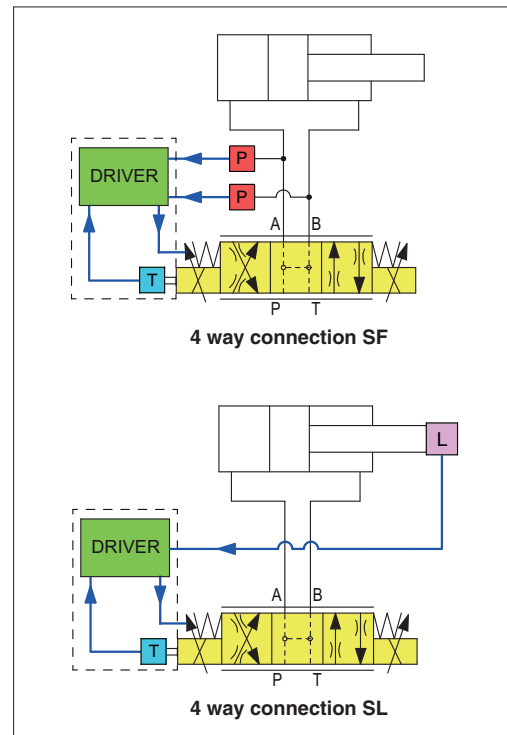

## 2.5 - Flow priority

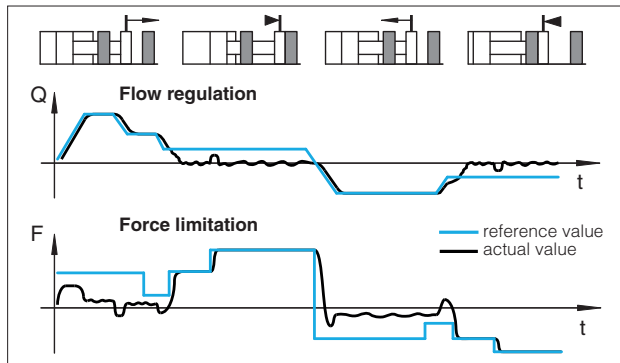

## 2.6 - Force priority

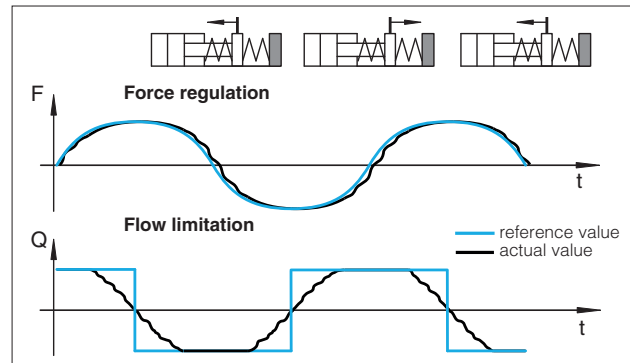

## 3 OPTIONAL SPOOLS FOR 4 WAY CONNECTION WITH SP CONTROL

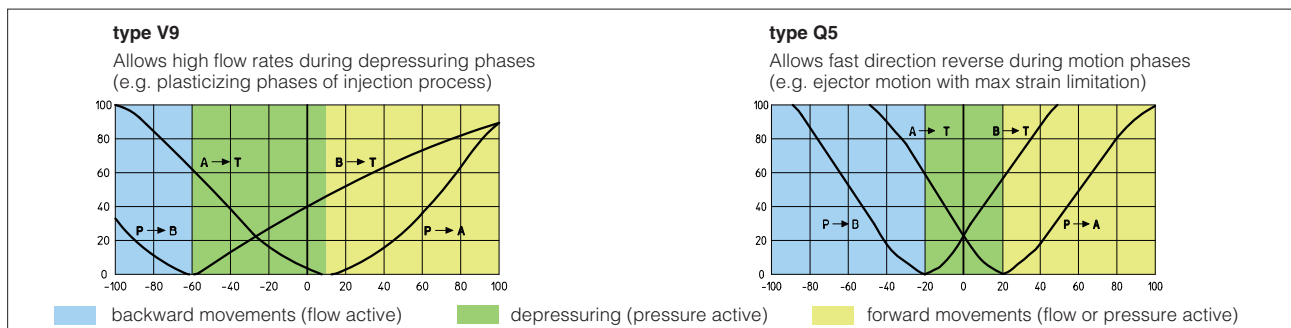

## 4 PRESSURE/FORCE TRANSDUCER CHARACTERISTICS

The accuracy of the pressure/force control is strongly dependent to the selected pressure/force transducers.

Pressure/force controls require to install remote pressure transducers or load cell to measure the actual pressure/force values:

- **Pressure Transducers:** allow easy system integration and cost effective solution for both pressure and force controls, see tech table **GS465** for pressure transducers details
- **Load Cell Transducers:** allow the user to get high accuracy and precise regulations for force control, but it increases the complexity of the mechanical installation

The characteristics of the remote pressure/force transducers must be always selected to match the application requirements and to obtain the best performances: transducer nominal range should be at least 115÷120 % of the maximum regulated pressure/force.