

Cable glands for Ex-proof valves

Multicertified ATEX, IECEx, EAC

1 MULTICERTIFIED CABLE GLAND FOR NON-ARMOURED CABLES - Group II (surface plants)

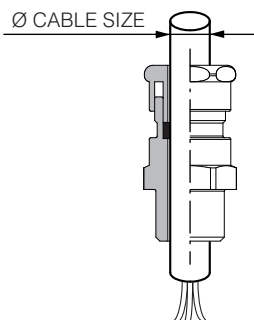

Cable glands for use with non-armoured plastic insulated cables
Flameproof **Exd IIC Gb**, Increased Safety **Exe IIC Gb** and Dust **Extb IIIC Db II 2 GD**, suitable for use in Zone 1, Zone 2, Zone 21, Zone 22.

Construction and Test Standards: IEC/EN 60079-0, IEC/EN60079-1, IEC/EN 60079-7 and IEC/EN 60079-31.

Ingress Protection: IP66, IP67 and IP 68 (30 metres for 7 days) to IEC/EN 60529 and NEMA 4X
Deluge Protection to DTS01

Operating Temperature Range: -60°C to +100°C

Material: Nickel Plated Brass or AISI 316

Cable glands are marked ATEX, IECEx and EAC

The electric cable must be suitable for the working temperature as specified in the "safety instructions" delivered with the first supply of Atos ex-proof valves.

See section 4 for cable gland assembly

CABLE GLAND CODE AND DIMENSIONS	MULTICERTIFICATION	CHARACTERISTICS	VALVE TYPE
<p>PAMC/GK</p> <p>Locking torque: 20 Nm</p>	<p>Referred to certificates: - Baseefa 06 ATEX0056X - IECEx BAS 06.0013X</p> <p>Item type: 501-421</p> <p>ATEX: EN 60079-0, EN 60079-1, EN 60079-7 and EN 60079-31</p>	<p>Material: Nickel plated brass</p> <p>Threaded connection: GK-1/2" ISO/UNI-6125 (tapered)</p> <p> cable size: 6,5 to 11,9 mm</p>	<p>On-off and proportional ex-proof valves with "GK" threaded connection (solenoid and transducer)</p>
<p>PAMC/M</p> <p>Locking torque: 20 Nm</p>	<p>IECEx: IEC 60079-0, IEC 60079-1, IEC 60079-7 and IEC 60079-31</p>	<p>Material: Nickel plated brass</p> <p>Threaded connection: M20x1,5 UNI-4535 (6H/6g)</p> <p> cable size: 6,5 to 11,9 mm</p>	<p>On-off and proportional ex-proof valves with "M" threaded connection (solenoid and transducer)</p>
<p>PAMC/NPT</p> <p>Locking torque: 20 Nm</p>	<p>EAC: EN60079-0 and EN60079-1</p>	<p>Material: Nickel plated brass</p> <p>Threaded connection: 1/2" NPT ANSI/ASME B1.20.1 (tapered)</p> <p> cable size: 6,5 to 11,9 mm</p>	<p>On-off proportional ex-proof valves with "NPT" threaded connection (solenoid and transducer)</p>
<p>PAXMC/M</p> <p>Locking torque: 20 Nm</p>		<p>Material: Stainless steel AISI 316</p> <p>Threaded connection: M20x1,5 UNI-4535 (6H/6g)</p> <p> cable size: 6,5 to 11,9 mm</p>	<p>On-off ex-proof stainless steel valves type "X" and "XS"</p>

2 MULTICERTIFIED CABLE GLAND FOR ARMoured CABLES - Group II (surface plants)

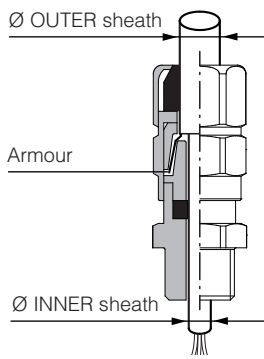

Cable glands for use with single wire armour 'W', wire braid 'X', steel tape armour 'Z', plastic insulated cables.

Flameproof **Exd IIC Gb**, Increased Safety **Exe IIC Gb**, Dust **Extb IIIC Db** and **ExnR IIC Gc II 2 / 3GD**, suitable for use in Zone 1, Zone 2, Zone 21, Zone 22.

Construction and Test Standards: IEC/EN 60079-0, IEC/EN 60079-1, IEC/EN 60079-7, IEC/EN 60079-15 and IEC/EN 60079-31.

Ingress Protection: IP66, IP67 and IP 68 (30 metres for 7 days) to IEC/EN 60529 and NEMA 4X Deluge Protection to DTS01.

Operating Temperature Range: -60°C to +80°C

Seal on the cable inner sheath

Outer deluge seal to prevent moisture ingress to the cable armour / braid





Cable retention, low smoke

Material: Nickel Plated Brass or AISI 316

Cable glands are marked ATEX, IECEx and EAC

The electric cable must be suitable for the working temperature as specified in the "safety instructions" delivered with the first supply of Atos ex-proof valves.

See section 4 for cable gland assembly

CABLE GLAND CODE AND DIMENSIONS	MULTICERTIFICATION	CHARACTERISTICS	VALVE TYPE
<p>PAAMC/GK</p> <p>Locking torque: 20 Nm</p>	<p>Referred to certificates: - Baseefa 06 ATEX0056X - IECEx BAS 06.0013X</p> <p>Item type: 501-453RAC</p> <p> </p>	<p>Material: Nickel plated brass</p> <p>Threaded connection: GK-1/2" ISO/UNI-6125 (tapered)</p> <p>able size: INNER sheath size 3,2 to 8 mm OUTER sheath size 5,5 to 12 mm</p>	<p>On-off and proportion- al ex-proof valves with "GK" threaded connection (solenoid and transducer)</p>
<p>PAAMC/M</p> <p>Locking torque: 20 Nm</p>	<p>ATEX: EN 60079-0, EN 60079-1, EN 60079-7 and EN 60079-31</p> <p> </p> <p>IECEx: IEC 60079-0, IEC 60079-1, IEC 60079-7 and IEC 60079-31</p>	<p>Material: Nickel plated brass</p> <p>Threaded connection: M20x1,5 UNI-4535 (6H/6g)</p> <p>able size: INNER sheath size 3,2 to 8 mm OUTER sheath size 5,5 to 12 mm</p>	<p>On-off and proportion- al ex-proof valves with "M" threaded connection (solenoid and transducer)</p>
<p>PAAMC/NPT</p> <p>Locking torque: 20 Nm</p>	<p></p> <p>EAC: EN60079-0 and EN60079-1</p>	<p>Material: Nickel plated brass</p> <p>Threaded connection: 1/2" NPT ANSI/ASME B1.20.1 (tapered)</p> <p>able size: INNER sheath size 3,2 to 8 mm OUTER sheath size 5,5 to 12 mm</p>	<p>On-off and proportion- al ex-proof valves with "NPT" threaded connection (solenoid and transducer)</p>
<p>PAAXMC/M</p> <p>Locking torque: 20 Nm</p>		<p>Material: Stainless steel AISI 316</p> <p>Threaded connection: M20x1,5 UNI-4535 (6H/6g)</p> <p>able size: INNER sheath size 3,2 to 8 mm OUTER sheath size 5,5 to 12 mm</p>	<p>On-off ex-proof stain- less steel valves type "X" and "XS"</p>

3 MULTICERTIFIED CABLE GLAND FOR ARMOURED CABLES - Group I (Mining)

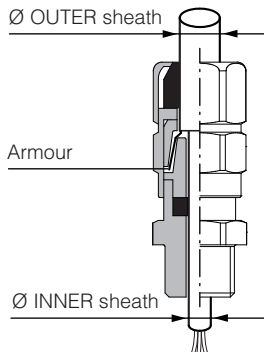





Cable glands for use with single wire armour 'W', wire braid 'X', steel tape armour 'Z', plastic insulated cables.

Flameproof **Exd I M2** and Increased Safety **Exe I M2**, suitable for use in Mines
 Construction and Test Standards: IEC/EN 60079-0, IEC/EN 60079-1 and IEC/EN 60079-7
 Ingress Protection: IP66, IP67 and IP 68 (30 metres for 7 days) to IEC/EN 60529
 Operating Temperature Range: -60°C to +80°C

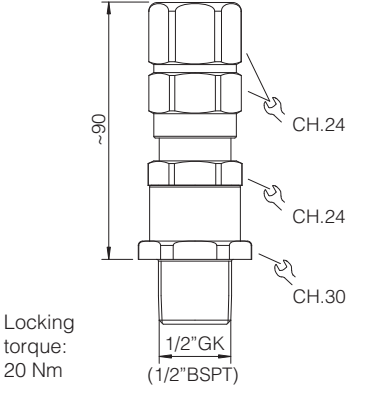
Seal on the cables inner sheath
 Cable retention, low smoke
 Material: Nickel Plated Brass
 Cable glands are marked ATEX, IECEx and EAC

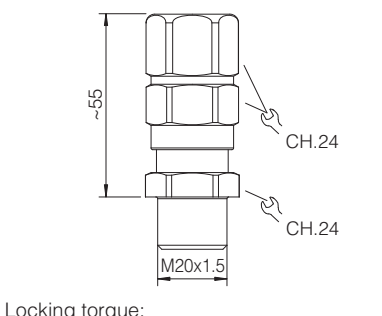
The electric cable must be suitable for the working temperature as specified in the "safety instructions" delivered with the first supply of Atos ex-proof valves.
 See section 4 for cable gland assembly

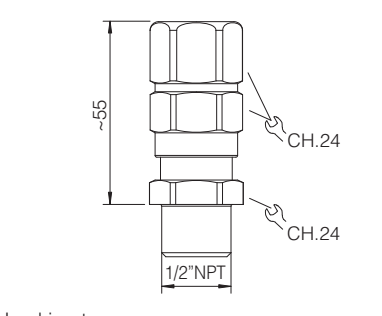
CABLE GLAND CODE AND DIMENSIONS	MULTICERTIFICATION	CHARACTERISTICS	VALVE TYPE
<p>PAAMMC/GK</p>  <p>Locking torque: 20 Nm</p>	<p>Referred to certificates: - Baseefa 08 ATEX0331X - IECEx BAS 08.0112X</p> <p>Item type: 453RAC</p>  <p>ATEX: EN 60079-0, EN 60079-1, EN 60079-7 and EN 60079-31</p>	<p>Material: Nickel plated brass</p> <p>Threaded connection: GK-1/2" ISO/UNI-6125 (tapered)</p> <p>able size: INNER sheath size 3 to 8 mm OUTER sheath size 5,5 to 12 mm</p>	<p>On-off and proportional ex-proof valves with "GK" threaded connection (solenoid and transducer)</p>
<p>PAAMMC/M</p>  <p>Locking torque: 20 Nm</p>	 <p>IECEx: IEC 60079-0, IEC 60079-1, IEC 60079-7 and IEC 60079-31</p>  <p>EAC: EN60079-0 and EN60079-1</p>	<p>Material: Nickel plated brass</p> <p>Threaded connection: M20x1,5 UNI-4535 (6H/6g)</p> <p>able size: INNER sheath size 3 to 8 mm OUTER sheath size 5,5 to 12 mm</p>	<p>On-off and proportional ex-proof valves with "M" threaded connection (solenoid and transducer)</p>
<p>PAAMMC/NPT</p>  <p>Locking torque: 20 Nm</p>		<p>Material: Nickel plated brass</p> <p>Threaded connection: 1/2" NPT ANSI/ASME B1.20.1 (tapered)</p> <p>able size: INNER sheath size 3 to 8 mm OUTER sheath size 5,5 to 12 mm</p>	<p>On-off and proportional ex-proof valves with "NPT" threaded connection (solenoid and transducer)</p>

Cable glands PAMC/* and PAXMC/M for non-armoured cables

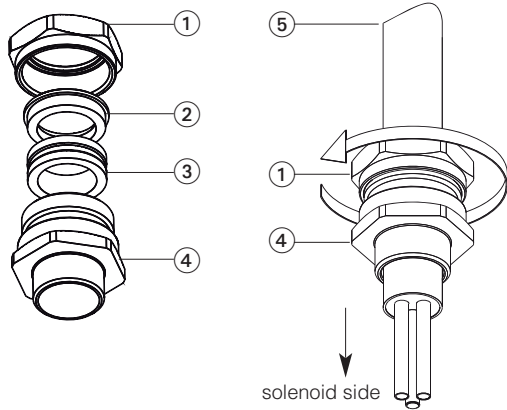

Assembling procedure

Unscrew the Back-nut ① from Entry ④
 Push the electric cable ⑤ through the cable gland
 Connect the cable wires to the solenoid terminal board
 Screw-in the Entry ④ into the solenoid cable entrance
 lock it at relevant tightening torque specified in section 1
 Lock the Back-nut ① using a wrench until a resistance is
 felt between internal seal ③ and the cable
 Turn the Back-nut ① through a further half turn to ensure
 the complete inner sealing

- ① Back-nut
- ② Compression Spigot
- ③ Seal
- ④ Entry
- ⑤ Electric cable (non-armoured)

Cable glands PAAMC/*, PAAXMC/M and PAAMMC/* for armoured cables

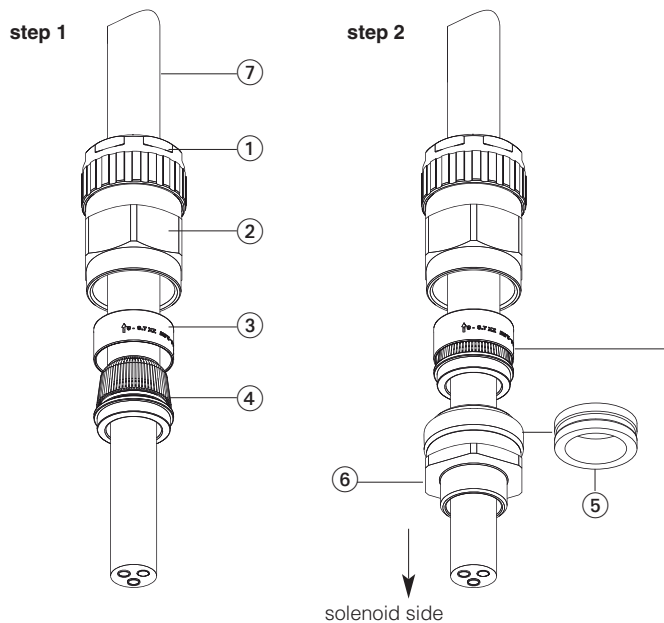

- ① Back-nut
- ② Middle-Nut
- ③ Reversible Armour Clamping Ring (RAC)
- ④ Armour Spigot
- ⑤ Inner Seal
- ⑥ Entry (with captive deluge seal), if required
- ⑦ Electric cable (armour type SWA, Braid X,
Flat Steel wire Y, Steel type Z)

Reversible Armour Clamping ring (RAC) orientation

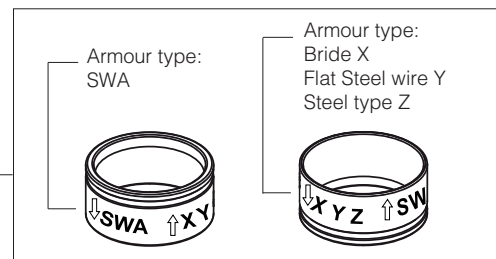

Note: the arrow corresponding to the correct armour type (SWA or X, Y, Z) must be oriented towards the ex-proof solenoid

Assembling procedure

step 1

Unscrew Back-nut ① from Middle-Nut ② and Entry ⑥
 Push the cable through the Armour spigot ④
 Spread the armour over the Armour spigot ④ until the end of the armour is up against the shoulder of the armour cone
 Position the Armour clamping ring ③ paying attention to its correct orientation depending to the armour type (see above)
 Remove the Inner seal ⑤ from the Entry ⑥
 Place the Entry ⑥ over the Armour spigot ④
 Move the sub-assembly ①+② to meet the entry ⑥
 Connect the cable wires to the solenoid terminal board
 Screw-in the Entry ⑥ into the solenoid cable entrance and lock it at relevant tightening torque specified in section 2 and 3
 Hand tighten the Middle nut ② to the Entry ⑥ and turn a further half turn with a wrench
 Unscrew the Middle nut ② and visually inspect that the armour has been successfully clamped between the armour spigot ④ and the armour clamping ring ③
 If the armour is not correctly clamped, repeat the assembly

step 2

Re-assemble Middle nut ② onto the components ③ + ④ + ⑤ + ⑥ paying attention to the correct orientation of the reversible armour Clamping ring ③
 Tighten up the Middle nut ② by hand first and then using a wrench a further 1 to 2 turns until fully tight
 Hand tighten the Backnut ① then tighten a further full turn using a wrench
 Ensure that the Middle nut ② does not rotate when tightening the Back-nut ①
 Ensure that the deluge seal is compressed into correct position