

Guidelines for the application of European Directives in electrohydraulics

The European Community issued a complete set of rules to improve and grant the workers' safety and health, as well as the correct operation of components and equipments. These general rules are:

Machine Directive - 2006/42/CE

Electromagnetic Compatibility Directive - EMC (2014/30/UE)

Low Voltage Directive - 2014/35/UE

Explosive Atmosphere Directive - ATEX (2014/34/UE)

IECEX - Certification Scheme for Explosive Atmospheres

Pressure Equipment Directive - PED (2014/68/UE)

Atos applies the CE mark on the whole range of its electrohydraulic components to certify their conformity to the above Directives, when applicable to their constructive and functional characteristics.

However the Atos CE marking does not relieve the manufacturer of the machine from testing and marking the machine in accordance with the above mentioned Directives and the relevant Harmonized Norms. The Directives define the general guidelines but they do not provide any specific technical requirement which are instead contained in the relevant Harmonized Norms - technical specifications addressed to different application fields (as explosion proof environments) or components (as safety components). They provide the technical requirements and the test specifications to which the components have to be submitted. The compatibility of the product characteristics with the Harmonized Norms have to be certified by an official Notified Body. The Notified Bodies are specific boards and agencies recognized by the European Community which perform the inspection, testing and the CE type certification of the components, machines and systems. They also perform the evaluation of the production quality assurance of the manufacturer.

- The **Machine Directive 2006/42/CE** replaces the 98/37/CE. This Directive defines the main requirements and the general guidelines for the designing and the manufacturing criterias applicable to the machines and to the specific components used for safety functions, in order to ensure the health protection from the risks generated by the machines functioning. For these machines and components the Directive imposes the manufacturer to certify the conformity of their products to the relevant Harmonized Norms
- The **EMC Directive 2014/30/UE** involves all the equipments which can cause electromagnetic disturbances and/or which can be influenced by them: it prescribes a sufficient immunity level to external disturbances and, at the same time, it fix a limited value for the generation of electromagnetic disturbances (emission). The relevant Harmonized Norms are: EN 61000-6-4 (Emission) and EN 61000-6-2 (Immunity)
- The **Low Voltage Directive 2014/35/UE** involves all electric components used in a range of nominal voltage from 50 to 1000 V alternate current and from 75 to 1500 V direct current. The Harmonized Norms are: EN 60730-1 and EN 60730-2-8, equivalent to the German VDE 0580 norm
- The **ATEX Directive 2014/34/UE** defines the manufacturing criteria and the safety requirements of the equipments used in potential explosive environments for presence of gas or flammable dusts. The Directive provides the classification and marking of the explosion proof components depending to:
 - protection mode
 - group of gas present in the environment
 - surface temperature of the component
 - zone of application, classified according to the risk level
 The relevant Harmonized Norms are: EN60079-1 and EN60079-2
- The **IECEX** is a voluntary program based on international standards (eg IEC) worldwide recognized, regarding the use of products in potentially explosive atmospheres. IECEX scheme provides certification of conformity for electrical equipment and machinery to be used in potential explosion-hazardous environments.
- The **PED Directive 2014/68/UE** defines the manufacturing criterias and the safety requirements relevant to the equipments and systems operating under pressure. For hydraulic equipments, the Directive imposes the certification and the CE marking for those components that, due to the operating pressure or to the product pressure per volume or nominal size, are within the limits classified by the Directive in 4 different classes

Atos R&D dept is active since many years in the development of safety components and options for hydraulic systems in cooperation with the main Notified Bodies recognized by the European Community. The Atos products involved in the above Directives are provided with CE marking and conformity certificate annexed to the products, as detailed in the following sections.

In any case the correct functioning of the components and the respect of the norms are assured only if the components are used in accordance with the relevant specifications and if the user's instructions are duly followed. These instructions are shown on the technical tables (see www.atos.com or KT Master Catalogue) and on the documentation annexed to the products (supply voltage tolerances, characteristics of the hydraulic fluids and the relevant class of contamination, working temperature, etc...).



Examples of Atos CE certificates provided by Notified Bodies: TÜV, CESI, IMQ



CESI



1 ATOS COMPONENTS IN COMPLIANCE WITH MACHINE DIRECTIVE (2006/42/CE)

In general valves, pumps, cylinders, servocylinders, servoactuators and hydraulic blocks are excluded from the Machine Directive unless they are delivered into the market as "safety components".

The Atos hydraulic components involved in the Machine Directive and thus subject to the CE marking are:

1.1 Lead sealed pressure relief valves (tab. C010 and C020) - fig. 1

Direct operated pressure relief cartridges, type CART-*/RS, and valves type ARE-*/RS, are specifically designed for application on safety blocks for vertical presses, and are factory set with lead sealed regulation, CE marked as per the Machine Directive. These valves are made in accordance with Harmonized Norms EN 693 and EN 12622. They are characterized by a special execution of the internal components and a protective cap locked on the adjustment screw by means of a metallic wire and a lead sealed to avoid unauthorized adjustment. For these valves Atos issues a CE Declaration of Conformity in accordance with the Machine Directive.

1.2 Safety solenoid valves and cartridges (tab. EY010, EY030, EY050, EY100, EY120) - fig. 2

2, 3, 4-way directional solenoid and cartridge valves (direct and pilot operated) are available with mechanical microswitch (option /FC) or inductive proximity sensor (option /FI) that detects the spool/poppet position. Such components can be used on machines for safety functions.

They are CE marked and they are certified by the TÜV according to the safety requirements provided by the Machine Directive and by the relevant Harmonized Norms.

Atos provides a technical data sheet based upon annex II of the Machine Directive and issues a CE Declaration of Conformity. These components are also in compliance with the EMC and Low Voltage Directive, see section 2.

1.3 Safety solutions for hydraulic presses - fig. 3

The Machine Directive imposes to the machine's manufacturers to satisfy specific safety requirements; for machines listed in annex IV of this Directive, e.g. vertical presses, these requirements are extremely severe. Atos has developed specific manifolds to be used on press brakes, torque bar or vertical presses in general, CE marked and certified by TÜV according to the Harmonized Norms UNI EN 12622: 2010, UNI EN ISO 13849-1: 2008 and certified by IMQ in accordance with the Machine Directive. For these manifolds Atos issues a CE Declaration of Conformity.

1.4 Hydraulic power-units - fig. 4

According to the Machine Directive, an hydraulic power unit, is considered as a partly completed machinery.

Atos system division, supplies the Declaration of Incorporation issued according to the Machine Directive and the Assembly Instructions containing the technical documentation relevant to the working conditions, safe incorporation, installation, commissioning and maintenance.

Compliance with harmonized standard EN ISO 4413 ensures compliance with all applicable requirements of the Directive.

1.5 Filling and filtering unit type GL-15

GL-15 are manufactured in conformity to Harmonized Norm EN ISO 4413, as they are considered complete machines and consequently they are subjected to CE marking according to the Machine Directive.

Atos issues a CE Declaration of Conformity in accordance with the Machine Directive and they provide technical documentations indicating the working conditions, and the instructions for safe commissioning, use and maintenance.

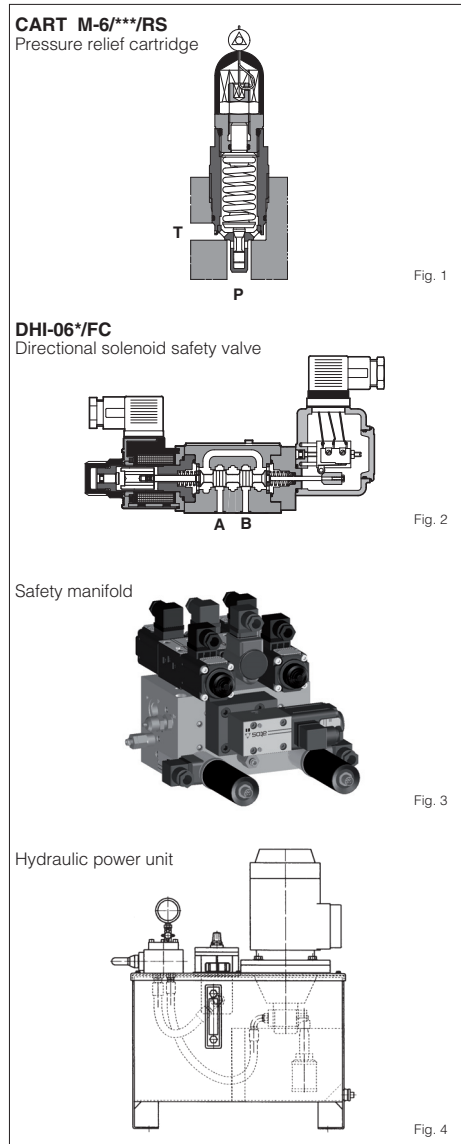

2 ATOS COMPONENTS IN COMPLIANCE WITH EMC DIRECTIVE (2014/30/UE) AND LOW VOLTAGE DIRECTIVE (2014/35/UE)

Atos constantly performs the verification of its components according to the applicable norms. In case of the EMC, the Directive 89/336/CE has been replaced from November '07 by the new 2004/108/CE. Thus all the components developed before that date are conform to the Directive 89/336/CEE, while the newest ones are in accordance with the new Directive 2004/108/CE.

2.1 Solenoid valves (tab. E010, E015, E025, E045, E085)

The Atos solenoid valves, direct and pilot operated, are marked CE to certify their conformity to the EMC and to the Low Voltage Directive, this last apply only to the coil voltages 110 and 220 Vdc; 110 and 230 Vac. The conformity refers to the valve's electrical parts (coils).

On request, Atos supplies the CE conformity declaration.

The electric connectors are not part of the valve and the relevant certification, if required, can be provided from the manufacturer.

Atos recommends the following instructions:

- Always protect the coils with a suppressor diode, to avoid peaks and discharges of the inductor, when it is de-energized;
- Grant the earth connection (via grounded subplates or manifolds or via the earth pin on the valve's coil);
- Always disconnect the main supply lines before the start-up and/or maintenance on the solenoid valves.

2.2 Proportional valves and electronic drivers (technical tables at sections F and G) - fig. 5

Atos proportional valves with or without transducer and the relevant integral or separated electronic driver are marked CE to certify their conformity to the EMC Directive. The respect of such Directive is granted only if the proportional valves are used in conjunction with Atos electronic drivers. On request, Atos supplies the CE conformity declaration.

Atos recommends the following instructions:

- For the valve, grant the earth connection (via grounded subplates or manifolds or via the earth pin available on the valve's coil);
- Shield all the connections to prevent the interference of electromagnetic disturbances; furthermore, provide the earth connections as shown in fig. 5;
- Use, if possible, an earth connection without disturbances (protected earth).

The electric signals of electronic drivers (e.g. reference, feedback and enabling signals) must not be used to perform the machine safety functions. This in accordance with the Harmonized Norm EN ISO 4413.

Always pay particular attention to the switch-on/off of the electronic regulators, since they could cause uncontrolled movements of the actuators driven by the relevant proportional valve. For further general information about installation and use of proportional valves and drivers, refer to section F of KT master catalogue.

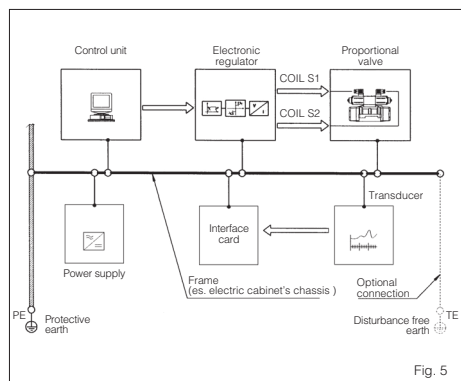

3 ATOS COMPONENTS FOR APPLICATIONS IN COMPLIANCE WITH ATEX DIRECTIVE 2014/34/UE

The Atos components involved in the ATEX Directive and thus subject to the CE marking are the whole range of valves provided with electrical solenoid actuation expressly designed for application in hazardous areas for presence of potentially explosive atmosphere. Additionally Atos provides a specific line of vane and piston pumps (see section 3.4) and cylinders (see section 3.5) ATEX certified for application in explosive environment. All the Atos components not equipped with electrical actuation (i.e. conventional valves, etc) are exempted from the ATEX certification because their functioning does not generate dangerous conditions for the explosive environment. For detailed analysis see section 4.

3.1 On-Off and proportional solenoid valves - fig. 6 and 7

These components are basically made by:

- electrical part for the valve actuation (solenoid) or for the spool position monitor (LVDT transducer), see section 3.2.
- mechanical part, comprehensive of external body and internal components for regulation, see section 3.3.

3.2 Electrical parts

Solenoids and LVDT position transducers are certified by **CESI** for application in potential explosive environment, in particular:

- Protection mode: **Ex II 2 G, Ex d IIC T6,T4,T3 Gb, Ex 2D Ex tb IIIC T85°/T135°/T200°C Db**, for surface plants with presence of gas and dust, category 2, zone 1, 2, 21 and 22.
- Protection mode: **Ex I M2 Ex db I Mb** for application in tunnels and mining plants with presence of grisou gas or flammable dust. The valve's power supply have to be switched off in case of explosive atmosphere.

Integral digital electronics and position transducers are certified according to protection mode **Ex II 2 G Ex db IIC T6, T5 Gb** for surface plants with presence of gas and vapours, category 2, zone 1 and 2.

The On-Off intrinsically safe solenoids are certified according to the protection mode:

- **Ex II 1 G Ex ia IIC T6 Ga (IIB T6, IIA T5)**, for surface plants with presence of gas or explosive mixture, category 1, zone 0, 1 and 2 (solenoid OW).
- **Ex I M2 Ex ia (ib) I Mb**, for application in tunnels and mining plants with presence of grisou gas or famable dust (solenoid OWM).

The intrinsically safe valves can respect the ATEX prescriptions only if connected to appropriate safety electronics barriers that limit the electrical power to the valve also in case of short circuit. For the correct functioning of the intrinsically safety valves, Atos recommend to check that the characteristics of the ATEX barriers are in compliance with the requirements specified in the Atos catalogue, (minimum current limits). For the best functioning of the valves use the barriers Y-BXNE-4120* shown in tab. GX010.

Note: Multicertifications **ATEX, IECEx, EAC**

Atos solenoid and proportional valves are multicertified according to ATEX Directive, IECEx Certification Scheme for Explosive Atmospheres and EAC.

The above exposed considerations about safety criteria, Harmonized Norms and protection mode are also valid for IECEx certification.

3.3 Mechanical parts

The mechanical part consist of the external valve body.

The safety of the mechanical parts in front of the application in the hazardous environment, is consequent to:

- All the internal parts are separated and insulated from the external environment by means of pressure-proof seals. The mechanical part is connected to the hydraulic circuit. Inside the body the internal volumes are filled by the hydraulic fluid, thus there are no internal volumes which can be saturated by the external atmosphere
- The mechanical part is not provided of any potential source which could cause the ignition of the explosive gas mixture because its functioning, also in case of failure, doesn't produce any sparks or overheating
- The functioning of the mechanical part does not create conditions (overheating, etc.) which may cause the explosion of the atmosphere.

3.4 PFEA vane and PVPCA piston pumps - fig. 9

PFEA and PVPCA are certified by TÜV for application in potential explosive environment, according to the protection mode **Ex II 2/2 GD cbk IIC T6/T5/T4**, for surface plants with presence of gas and dust, category 2, zone 1, 2 and 21, 22

3.5 CKA Hydraulic cylinders - fig. 10

CKA cylinders are certified by TÜV for application in potential explosive environment, in particular:

- CKA cylinders are certified with Notification n° **TÜV 09 ATEX 366333**, according to the protection mode: **Ex II 2 GD ck IIC T6,T4**, for surface plants with presence of gas or dust, category 2, zone 1, 2, 21 and 22
- They can be supplied with explosion proof magnetosonic position transducer (CKAM), ATEX certified, according to the following protection modes:
 - Ex II 1/2 G Ex d IIB + H2 T6 X**, for surface plants with presence of gas or explosive mixture, category 2, zone 1 and 2;
 - Ex tD IP67 T85°C**, for surface plants with presence of dust, category 2, zone 22
- CKA cylinders are also available with explosion proof proximity sensors (options **R,S**), ATEX certified to **Ex II 3G Ex nA II T4 X**, for surface plants with presence of gas, category 2, zone 2.

DLHZA-T*

Explosion-proof valve

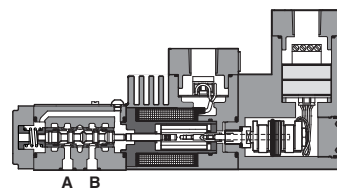

Fig. 6

DKZA-TEs*

Explosion-proof valve

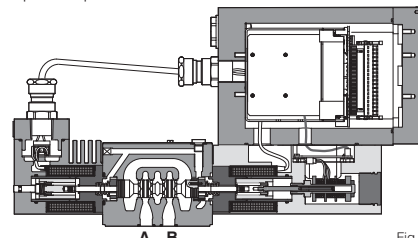

Fig. 7

DHW-06

Intrinsically safe-valve

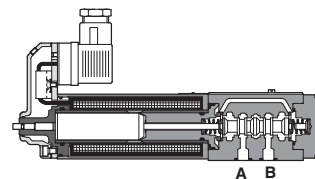

Fig. 8

PFEA

Vane pump with explosion proof ATEX certification

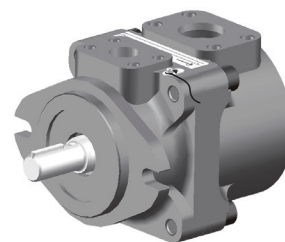

Fig. 9

CKAM

ATEX cylinder with explosion proof position transducer

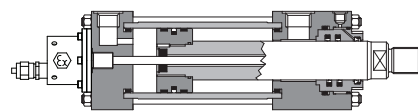

Fig. 10

4 ATOS COMPONENTS FOR APPLICATIONS IN EXPLOSIVE ENVIRONMENT EXEMPTED FROM ATEX AND IECEx CERTIFICATION

4.1 On-off pressure control valves, flow control valves, check valves, modular valves

For the valves with mechanical control the same considerations shown in the section 3.3 can be applied. For application in hazardous environment are excluded the fast/slow valves, type DHQ valves described in tab. D170.

4.2 On-off directional control valves

For the application in the potential explosive environment are excluded the safety valves provided of mechanical switch or inductive proximity switch (table E110 and E115).

The valves provided of electrical control are certified as described in section 3.1.

For the valves with mechanical, hydraulic and pneumatic controls the same considerations shown in the section 3.3 can be applied.

4.3 On-off ISO cartridge valves

The solenoid operated cartridges are certified as described in section 3.1.

For the hydraulic operated cartridges, the same considerations shown in the section 3.3 can be applied.

5 ATOS COMPONENTS IN COMPLIANCE WITH PED DIRECTIVE (2014/68/UE)

According to the requirements of the PED Directive the hydraulic components subject to the CE marking are:

- Components to be used with fluids of group 2 whose operating pressure is greater than 1000 bar and/or components whose product pressure x volume is greater than 10000 bar x liter;
- Components designed for pressure safety applications;
- Power units with accumulators having a volume greater than 1 liter and only if connected to the actuators.

5.1 Pumps, valves and cartridges

These components, identified by the article 3, point 1.1 of the PED Directive, are designed to be used with fluids of group 2, they have a product pressure x volume under pressure always less than 10000 bar x liter and their max working pressure is always lower than 1000 bar. Thus they are exempted by the CE marking, according to the article 3, paragraph 3 of the PED Directive.

PED pressure relief safety valves, (tab. C010, C020, C045 and C066) - fig. 11

These valves, identified by the article 3, point 1.4 of PED Directive, are CE marked and they are certified by **IMQ**

- Category: IV
- Procedure for the conformity evaluation: Module B (CE-type examination) + D (manufacturing quality assurance)

They are supplied with Atos conformity declaration and with the installation, commissioning and maintenance guidelines.

5.2 Cylinders

Atos cylinders, identified by the article 3, point 1.1 of PED Directive, are designed to be used with fluids of group 2 and their working pressure is always less than 1000 bar.

The cylinders with long stroke can exceed the product pressure x volume under pressure of 10000 bar x liter, in this case they are CE marked and they are supplied with the Atos CE conformity declaration.

- Category: I
- Procedure for the conformity evaluation: Module A (factory manufacturing inspection).

5.3 Hydraulic systems accessories

- subplates series BA-***, technical tables K280, K290 and K295

The above components, identified by the article 3, point 1.1 of PED Directive, are designed to be used with fluids of group 2, they have a product pressure x volume under pressure less than 10000 bar x liter and their max working pressure is always lower than 1000 bar. Thus they are exempted by the CE marking, according to the article 3, paragraph 3 of the PED Directive.

Accumulators

The accumulators with a volume ≤ 1 liter and with a max working pressure less than 1000 bar, identified by the article 3, point 1.4 of the PED Directive, are exempted by the CE marking, according to the article 3, paragraph 3 of the PED Directive.

For these accumulators it is valid the declaration released by the manufacturer and available by Atos Quality Assurance department.

It is declared that the accumulators having a volume > 1 liter, identified by the article 3, point 1.4 of the PED Directive, are designed to be used with fluids of group 2 and they are classified depending on the volume and on the max working pressure according to one of the four classes of the Directive listed in section 5.4.

The accumulators subjected to the CE marking are supplied with the CE conformity declaration plus the installation, commissioning and maintenance manual, directly provided by the accumulator manufacturer.

Manometers

The manometers, identified by the annex 1, article 2.10 b of the PED Directive, having a max pressure ≤ 200 bar are exempted by the CE marking according to the article 3, paragraph 3 of the PED Directive

For these manometers it is valid the declaration released by the manufacturer and available by Atos Quality Assurance department.

The manometers, identified by the annex 1, point 2.10 b of the PED Directive, having a max pressure > 200 bar, are classified in the Class I of the Directive, therefore they are subjected to the CE marking. These manometers are supplied with the CE Conformity declaration directly released by the manufacturer.

Other accessories for power units

All the components relevant to the above section, identified by the article 3, point 1.1 of the PED Directive, are designed to be used with fluids of group 2, they have a product pressure x volume under pressure always less than 10000 bar x liter and the max working pressure is always lower than 1000 bar. Thus they are exempted by the CE marking, according to the article 3, paragraph 3 of the PED Directive.

For these components are valid the declarations released by the manufacturers and available by Atos Quality Assurance department.

5.4 Hydraulic power units

The hydraulic power units, if equipped with accumulators having a volume > 1 liter, identified by the article 3, point 2 of PED Directive, following the installation on the machine and the connection to the actuators, are considered hydraulic assemblies, as per article 1, point 1 which have to be evaluated, certified and CE marked according one of the following classes of the Directive:

- Class I: when $PS \times V \leq 50 < 200$; Machine manufacturer self conformity certification
- Class II: when $PS \times V \leq 1000$; Conformity certified by Notified Body
- Class III: when $PS \times V \leq 3000$; Conformity certified by Notified Body
- Class IV: when $PS \times V > 3000$; Conformity certified by Notified Body

PS = Max design pressure **V** = accumulator volume (of single accumulator)

The Atos technical dept. on request can provide the support for the evaluation of the above hydraulic assembly's class.

On request Atos can supply the power units certified and CE marked according the PED Directive, therefore comprehensive of components for pressure safety function.

The certification of the power unit represent an important advantage in front of the certification of the whole hydraulic assembly, that must be provided by the machine manufacturer. In fact in this case the customer certification is reduced only to the inspection of the compatibility of the max pressure of the equipments used in the machine with the max pressure provided by the power unit design.

Each single power unit is provided of installation, commissioning and maintenance manual, containing the relevant CE/PED certificate reporting the power unit series number and the relevant technical descriptions.

- Evaluation procedure of the conformity: Module H1
- Notified body: **IMQ**

