

# Testing box type E-RI-TEST

for proportional valves with on-board electronic driver

Available only on request

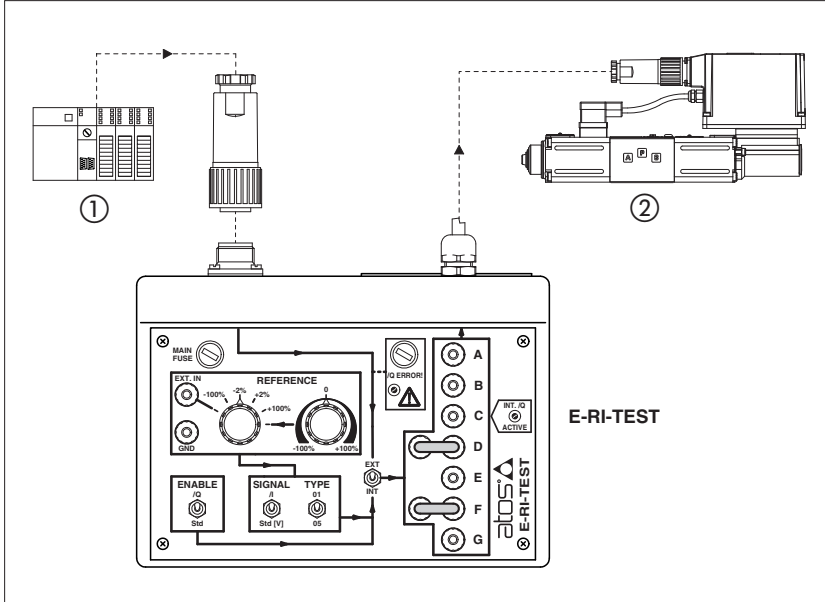

## E-RI-TEST

Testing box allows to test and start-up proportional valves with on-board electronic driver with 7 pin main connector.

It is supplied with 2m cable and with 7 pin main connector, to directly connect the valve driver to be tested.

E-RI-TEST can be used in two operate modalities thanks to a switch selector placed on the frontal panel:

### Test:

- the E-RI-TEST has to be connected between the machine central unit ① and the proportional valve ②. During normal working it is possible to monitor the state and value of all signals of the 7 pins connector. It is not necessary to supply the valve electronic driver.

### Start-up:

- the E-RI-TEST operates by multi-selectable potentiometers and switches selectors placed on the frontal panel. With this mode it is possible to start-up the valve with preliminary movements at low speed thanks to an internal reference generator. The machine central unit ① and all signal management have not to be connected to the E-RI-TEST. The power supply must be connected to the pin A, B of the main connector (see section ③).

## 1 MODEL CODE

E-RI-TEST

Testing box for valves with on-board electronics and 7 pin main connector

\*

Series number

## 2 BLOCK DIAGRAM

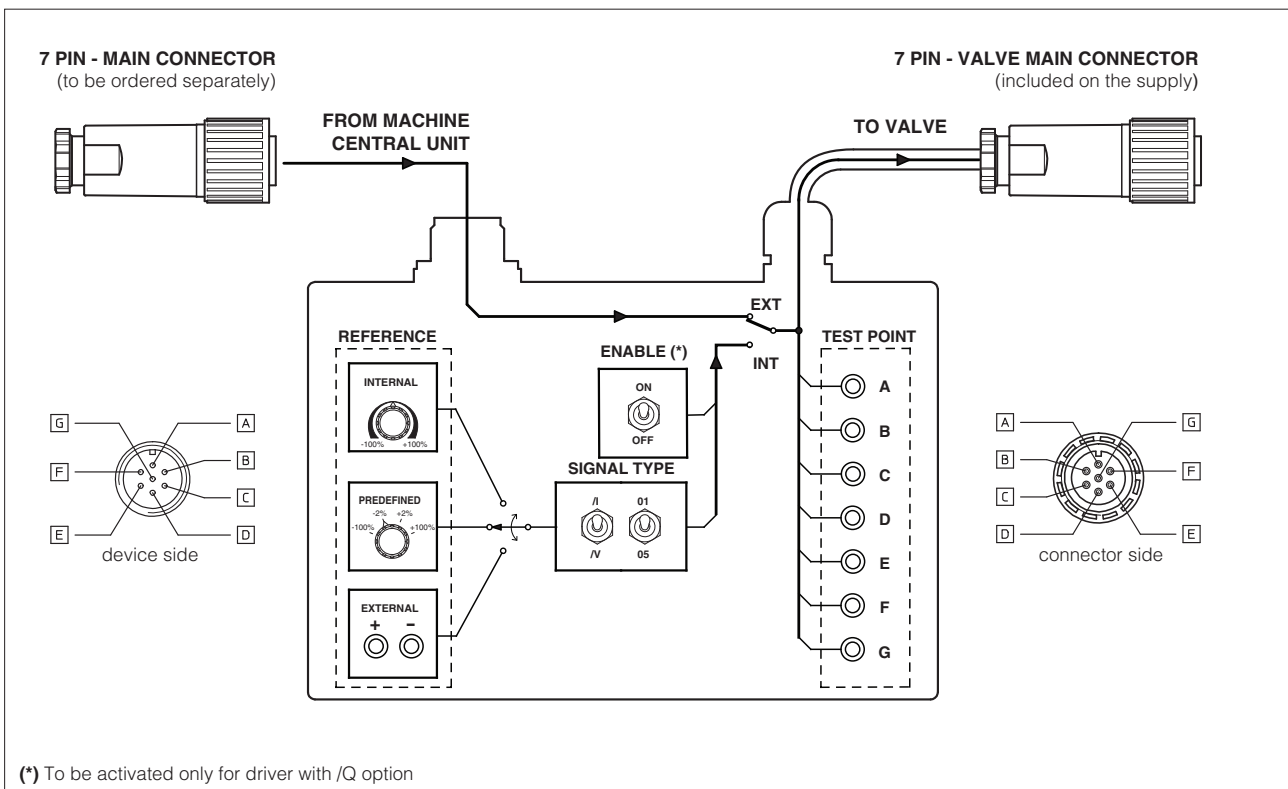

### 3 ELECTRONIC CONNECTIONS

PIN	SIGNAL	TECHNICAL SPECIFICATIONS	NOTES
A	V+	Power supply 24 Vdc for solenoid power stage and driver logic	Input - power supply
B	V0	Power supply 0 VDC for solenoid power stage and driver logic	Gnd - power supply
C (1)	AGND	Ground - signal zero for MONITOR signal	Gnd - analog signal
	ENABLE	Enable (24 Vdc) or disable (0 Vdc) the driver (for /Q option)	Input - on/off signal
D	INPUT+	Reference analog differential input: $\pm 10$ Vdc maximum range (4 $\div$ 20 mA for /I option) For single solenoid valves : 0 $\div$ 10 VDC (4 $\div$ 20 mA for /I option)	Input - analog signal
E	INPUT -	For double solenoid valves: $\pm 10$ VDC (4 $\div$ 20 mA for /I option)	
F (2)	MONITOR	Monitor analog output: $\pm 10$ VDC maximum range (4 $\div$ 20 mA for /I option)	Output - analog signal
	FAULT	Fault (0 Vdc) or normal working (24 VDC) (for /F option)	Output - on/off signal
G	EARTH	Internally connected to the test adapter housing	

(1) With /Q option ENABLE signal replaces AGND on pin C; MONITOR signal is referred to pin B

(2) With /F option FAULT signal replaces MONITOR on pin F

### 4 TECHNICAL CHARACTERISTICS

Power supply	Nominal: +24 VDC rectified and filtered: $V_{rms} = 20 \div 32 V_{MAX}$ (ripple max 10 % VPP)
Max. power consumption	10 W
Reference input signal	Voltage: $\pm 10$ VDC Current: 4 $\div$ 20 mA
Input signal impedance	Voltage: $R_i > 50 k\Omega$ Current: $R_i = 316 \Omega$
External potentiometers Reference	$\pm 2\%$ of input signal range - to be used for positive/negative bias setting $\pm 100\%$ of input signal range - to be used for positive/negative scale setting $\pm 100\%$ continuous range - to be used for preliminar movements
Box format	plastic box with aluminium front end; IP20 protection degree
Operating temperature	-20 $\div$ +60 °C (storage -20 $\div$ +70 °C)
Dimensions	221 x 150 x 100 mm
Mass	1,5 kg (included cable + connector)

### 5 COMPONENTS IDENTIFICATION

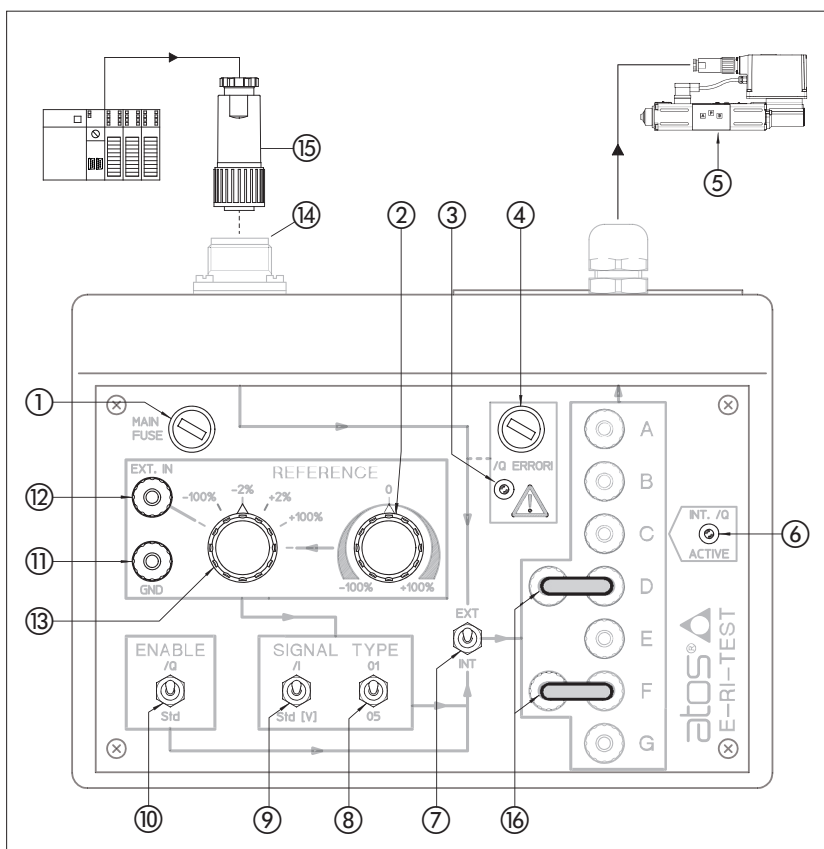

- ① Main fuse, 4A
- ② Internal reference potentiometer:  $\pm 100\%$
- ③ Enable signal in pin C;
- ④ Protection fuse in case pin C is supplied by Enable signal (on valves without /Q option)
- ⑤ Proportional valve
- ⑥ LED on when Enable is active
- ⑦ Internal / External reference selector
- ⑧ Single solenoid (01) / double solenoid (05) valve selector
- ⑨ Voltage (Std [V]) / Current (/I) reference selector
- ⑩ Enable signal selector - to be used only on valves with /Q option)
- ⑪ GND external reference plug
- ⑫ Positive external reference plug
- ⑬ Reference multi selector
- ⑭ 7 pin panel male connector
- ⑮ 7 pin main female connector and cable from PLC (not included on the supply)
- ⑯ Jumpers (see 6.4)

## 6 OPERATING WITH E-RI-TEST

The E-RI-TEST must be interposed between the Machine Control Unit through the main connector ⑮ and the proportional valve ⑤ through the annexed connector and cable.

### 6.1 Power supply

The power supply must be provided through pin A and B of the main connector of the E-RI-TEST.

A safety fuse is present in series to the power supply:  $\varnothing 5 \times 20$  (4A, F).

Never use the test point A and B to provide power supply to the valve connected: these test points must be used to check power supply presence on the pin A and B of proportional valve main connector.

### 6.2 External reference signal

It is used for test operations and it is active with switch ⑦ set to **EXT**. In this condition it is required to connect the Machine Control Unit connector ⑭ to the plug ⑮ and to connect E-RI-TEST to the main connector of the proportional valve ⑤. The user can monitor the valve signals using the test point available on the front panel of the device (see section ② for details).

- pins A...G replicate the correspondent ones of the on-board electronics and it is possible to measure the relevant signals

- /Q fuse ④ protects erroneous enable signal (24 Vdc) on pin C if the on-board electronic driver is not equipped with /Q function:

in this case light ③ is on.

Replace the fuse and check selector ⑩ is on Std position

### 6.3 Internal reference signal

This configuration is used for start-up operation, and it is active with switch ⑦ set to **INT**.

Possible functions:

- to run preliminary valve movement

- to change settings through the reference multi-selector ⑬ of device front panel

- to test or change the valve parameter settings

It is not requested the Machine Control Unit.

- pins A...G: connect these pins to monitor the relevant signals according to the electronic connections (see section ③)

- enable ⑩ for /Q option: when it is active the light ⑥ is on. If the enable pin is wrong connected, the light ③ is switched on

- reference type (V, I) internal position by selector ⑨ and valve configuration selection ⑧

position 01: reference  $4 \div 20 \text{ mA} / 0 \div +10 \text{ Vdc}$

position 05: reference  $4 \div 20 \text{ mA} / -10 \div +10 \text{ Vdc}$

- reference signal can be supplied as follows:

- selector ⑬ set to EXT.IN: any external reference signal can be supplied to the female jacks ⑪ and ⑫
- selector ⑬ set at -100%, or -2%, or +2%, or +100%: in this way maximum and threshold reference signals are selected
- selector ⑬ set to enable the internal reference ②: any reference signal can be selected on potentiometer on the range  $\pm 100\%$

### 6.4 Jumpers

Jumpers ⑭ are used to simplify any measurements with external multi-meters:

- current measurement ⑰: disconnect jumper on D or F pins and connect probes in-series
- voltage measurement ⑱: connect probes between D or F pins and system ground

**Note:** jumpers have to be connected for regular working operations

### 6.2 External reference signal

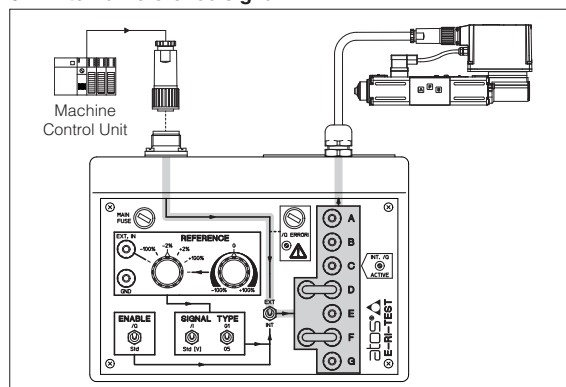

### 6.3 Internal reference signal

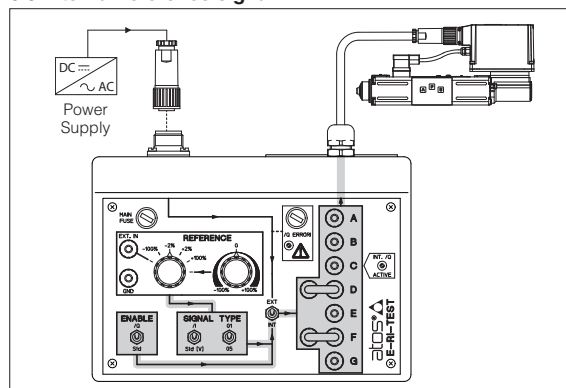

### 6.4 Jumpers

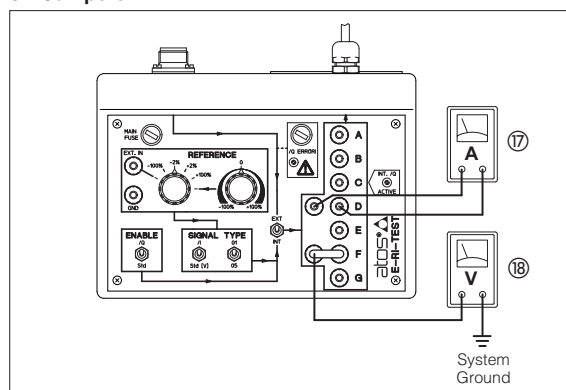

## 7 CONNECTORS CHARACTERISTICS - to be ordered separately

CODE	ZH-7P	ZM-7P
Type	Female straight circular socket plug 7pin	Female straight circular socket plug 7pin
Standard	According to MIL-C-5015	According to MIL-C-5015
Material	Plastic reinforced with fiber glass	Aluminium alloy with cadmiun plating
Cable gland	PG11	PG11
Cable	LiYCY 7x 0,75 mm <sup>2</sup> max 20 m (logic and power supply) or LiYCY 7 x 1 mm <sup>2</sup> max 40 m (logic and power supply)	LiYCY 7x 0,75 mm <sup>2</sup> max 20 m (logic and power supply) or LiYCY 7 x 1 mm <sup>2</sup> max 40 m (logic and power supply)
Connection type	to solder	to solder
Protection (DIN 60529)	IP 67	IP 67

8 OVERALL DIMENSIONS [mm]

**ZM-7P - MAIN CONNECTOR**  
7 pin - metallic  
(to be ordered separately)

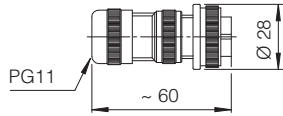

**ZH-7P - VALVE MAIN CONNECTOR**  
7 pin - plastic  
(included on the supply)

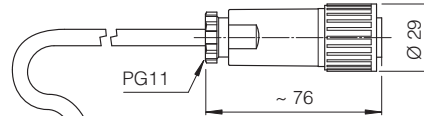

**ZH-7P - MAIN CONNECTOR**  
7 pin - plastic  
(to be ordered separately)

