

Explosion-proof solenoid valves

on/off and proportional controls - cULus certification

obsolete components - availability on request

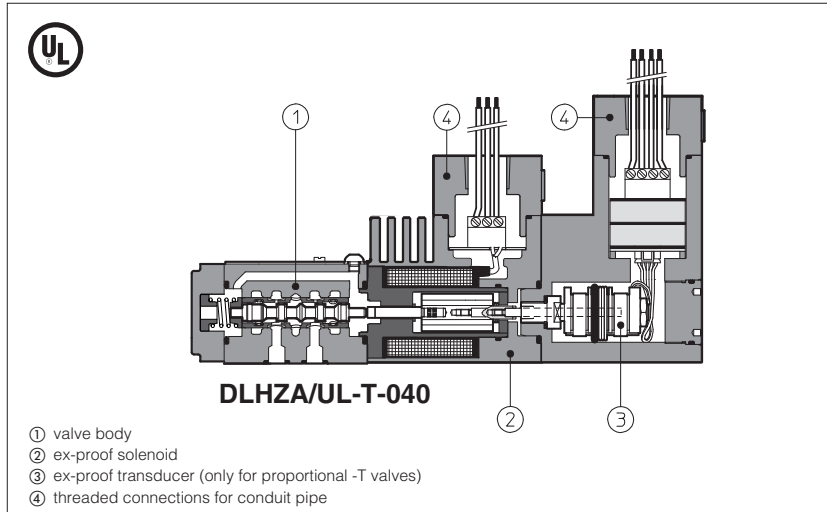

Explosion-proof on/off and proportional solenoids certified cULus according to UL 1002 and CSA 22.2 n°139-1982 Standard, Class I, Groups C&D (Groups IIA & IIB to NEC 505-7).

The solenoid case is designed to contain the possible explosion which could be caused by the presence of the gas mixture inside the housing, thus avoiding dangerous propagation in the external environment.

DHA and DLAH valves are **SIL** compliance with IEC 61508 (TÜV certified) - see section 3.2

They are also designed to limit the external temperature according to the certified class to avoid the self ignition of the explosive mixture present in the environment.

These solenoids are applied to hydraulic valves for application in explosion-hazardous environments.

1 EXPLOSION PROOF SOLENOIDS: MAIN DATA

SOLENOID TYPE	PROPORTIONAL		ON-OFF
	without transducer	with transducer	
Solenoid code	OZAUL-A	OZAUL-T	OAUL
Voltage code	VDC ±10% VAC 50/60 Hz ±10%	12 DC, 24 DC	12DC, 24DC, 110DC, 125DC, 220DC
Power consumption	35W		12W
Coil insulation	Class H		
Protection degree	IP 67 According to IEC 144 when correctly coupled with the relevant conduit pipe		
Duty factor	100%		
Mechanical construction	Flame proof housing classified, according to UL 1002 and CSA 22.2 n°139-1982, class I, groups C&D (Groups IIA & IIB to NEC 505-7)		
Cable entrance and electrical wiring	Connection 1/2" NPT (ANSI B2.1) for conduit pipe. The valves are supplied with 1,07 m (42 inches) cable length factory wired - cable size AWG 16		

(1) For alternating current supply a rectifier bridge is provided built-in the solenoid

2 EXPLOSION PROOF SOLENOIDS: TEMPERATURE DATA

SOLENOID TYPE	PROPORTIONAL	ON/OFF
Method of protection	Ex d	
Temperature class with +70°C ambient temp.	T4	Not applicable
Surface temperature	≤135 °C	≤ 85 °C
Ambient temperature	-40 ÷ +70 °C	

3 CERTIFICATIONS

In the following is resumed the valves marking according to UL 1002 and CSA 22.2 n° 139-1982 certification

- Class I** = Equipment for famable gas and vapours
- Division 1** = Possibility of explosive atmosphere during normal functioning
- Groups C&D** = Gas group (according to UL 1002)
- Groups IIA&IIB** = Gas group (according to NEC 505-7)
- T4** = Temperature class of solenoid surface referred to +70°C ambient temperature

3.2 SIL compliance with IEC 61508: 2010

DHA/UL and DLAH/UL meets the requirements of:

- **SC3** (systematic capability)
- max **SIL 2** (HFT = 0 if the hydraulic system does not provide the redundancy for the specific safety function where the component is applied)
- max **SIL 3** (HFT = 1 if the hydraulic system provides the redundancy for the specific safety function where the component is applied)

3.1 EXAMPLE OF NAMEPLATE MARKING

MODEL CODE

SERIAL N° LISTED 48AM Solenoid for use in hazardous locations

Class I, Groups C & D Temperature code **T4**

Class I, Groups IIA & IIB Temperature code **T4**

Max ambient temp. 70° C 158° F

Electrical rating :

See instructions for use with pulse width modulated (PWM) inverter

CAUTION: To reduce the risk of ignition of hazardous atmospheres, disconnect from circuit before opening enclosure. Keep tightly closed when in operation. T-764

Marking according to NEC 505-7 norms

Marking according to UL 1002 norms

C UL US identification mark

4 MODEL CODE OF SPOOL TYPE ON-OFF DIRECTIONAL SOLENOID VALVES

<p>DHA = spool type - direct DPHA = spool type - piloted</p> <p>UL = C UL US certification</p> <p>Valve size (ISO 4401) for DHA 0 = 06 for DPHA 1 = 10 2 = 16 4 = 25 6 = 32</p> <p>Valve configuration, DHA see section 5 and DPHA see section 6</p> <p>Spool type, DHA see section 5 and DPHA see section 6</p> <p>Solenoid threaded connection: NPT = 1/2" NPT ANSI B2.1 (tapered)</p>	<p>/UL - 0 63 1/2 / NPT / *</p> <p>24DC</p> <p>**</p> <p>/*</p> <p>Seals material: omit for NBR (mineral oil & water glycol) PE = FPM Low temperature execution: BT = low temperature -40°C</p> <p>Series number</p> <p>Voltage code - see section 11</p>
--	---

- Options:
- A** = solenoid at side of port B (for single solenoid valves)
 - O** = horizontal cable entrance
 - MV** = vertical hand lever (1)
 - WP** = prolonged manual override protected by metallic cap
- Only for DPHA:
- /D** = Internal drain
 - /E** = External pilot pressure
 - /H** = Adjustable chokes (meter-out to the pilot chambers of the main valve).
 - /H9** = Adjustable chokes (meter-in to the pilot chambers of the main valve)
 - /L9** = (only for DPHA-2 and DPHA-4) plug with calibrated restrictor on port P of pilot valve
 - /S** = Main spool stroke adjustment (only for DPHA-2, -4)

(1) Option **/MV** available only for DHA, configuration 61, 63, 71 and spool type 0, 0/2, 1, 1P, 1/2, 1/2P, 3, 3P, 4, 7

5 CONFIGURATIONS and SPOOLS for DHA valves

<p>Configurations</p>	<p>Spools</p>	<p>Configurations</p>	<p>Spools</p> <p>not for configuration 75</p> <p>only for spool 0/2 and 1/2</p>
-----------------------	---------------	-----------------------	---

6 CONFIGURATIONS and SPOOLS for DPHA valves

<p>Configurations</p>	<p>Spools</p>	<p>Configurations</p>	<p>Spools</p> <p>not for configuration 75</p> <p>only for spool 0/2 and 1/2</p>
-----------------------	---------------	-----------------------	---

NOTES:

- For **DP*-1** are available only spools: **0, 0/2, 1, 1/2, 3, 4, 5, 58, 6, 7**
- For **DP*-6** are available only spools: **0, 1, 2, 3, 4, 5, 58, 6, 7, 8, 19, 91**

7 MODEL CODE OF POPPET TYPE, LEAK FREE, DIRECTIONAL SOLENOID VALVES

DLAH /UL - 2 A / NPT / * 24DC ** /*

Directional control valve poppet type, size 06
DLAH = max flow 12 l/min
DLAHM = max flow 30 l/min

UL = C UL US certification

2 = two way (only for DLAH)
 3 = three way

Valve configuration, see section 8
A = open in rest position
C = closed in rest position

Seals material (1):
 omit for NBR (mineral oil & water glycol)
PE = FPM

Series number

Voltage code - see section 11

Options:
O = horizontal cable entrance
R = with check valve on port P (only for DLAH)
WP = prolonged manual override protected by metallic cap

Solenoid threaded connection:
NPT = 1/2" NPT ANSI B2.1 (tapered)

(1) Option /BT = low temperature -40°C also available on request

8 CONFIGURATION OF DLAH AND DLAHM

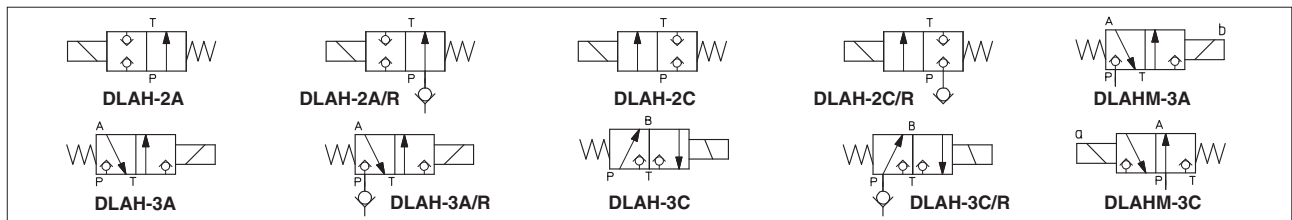

9 Q/Δp DIAGRAMS OF ON/OFF DIRECTIONAL CONTROLS (based on mineral oil ISO VG 46 at 50°C)

Flow direction \ Spool type	Flow direction				
	P→A	P→B	A→T	B→T	P→T
0	C	C	C	C	
0/2, 1, 1/2	A	A	A	A	
3	A	A	C	C	
4, 5	D	D	D	D	A
6	A	A	C	A	
7	A	A	A	C	
8	C	C	B	B	

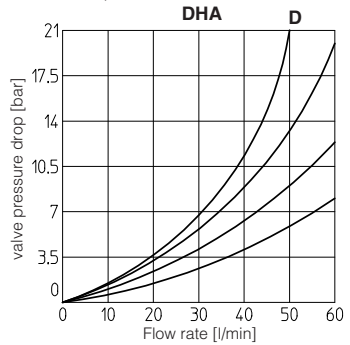

INTERNAL LEAKAGE of DLAH and DLAHM less than 5 drops/min (0,36 cm³/min) at max pressure.

Flow direction \ Valve type	Flow direction	
	P → A (1) (P → B)	A → T (B → T)
DLAH-2A	B	-
DLAH-2C	C	-
DLAH-3A	D	C
DLAH-3C	C	A
DLAHM-3A	G	F
DLAHM-3C	F	E

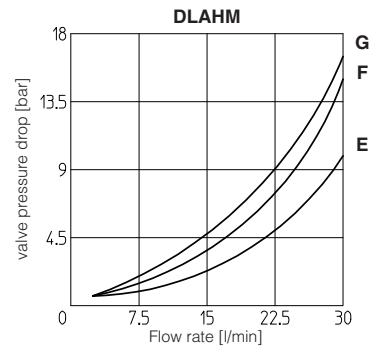
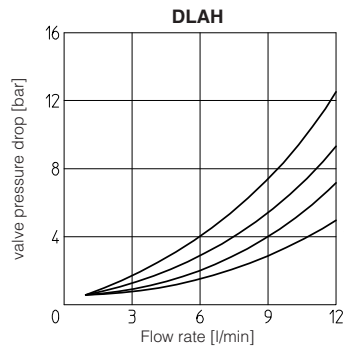

(1) For two-way valves pressure drop refers to P→T

10 OPERATING LIMITS OF ON/OFF DIRECTIONAL CONTROLS (based on mineral oil ISO VG 46 at 50°C)

The diagram have been obtained with warm solenoids and power supply at lowest value ($V_{nom}-10\%$). For DHA valves the curves refer to application with symmetrical flow through the valve (i.e. P → A and B → T). In case of asymmetric flow the operating limits must be reduced.

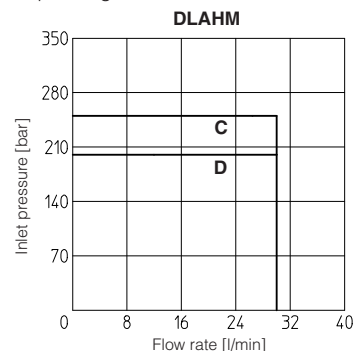
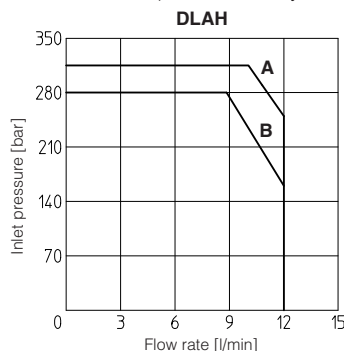
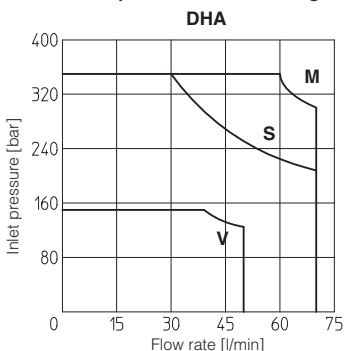

M = Spools 0, 1, 8; **V** = Spools 4, 5.
S = Spools 0/2, 1/2, 3, 6, 7;

A = DLAH-3A;
B = DLAH-2A, DLAH-3C.

C = DLOK-3A;
D = DLAHM-3C.

10.1 Max pressure in port T = 210 bar

11 MODEL CODE OF PRESSURE RELIEF VALVES

AGAM - 20 / 2 0 /210/100/100 / NPT - AO/UL / * 24 DC ** /*

AGAM = pressure relief valve: subplate mounting, see tab. C066
ARAM = pressure relief valve: threaded connections, see tab. C045

Valve size
 for AGAM: 10 (ISO 6264) 20 (ISO 6264) 32 (ISO 6264)
 for ARAM: 20 = G 3/4" 32 = G 1 1/4"

Number of the different setting pressure values:
 1 = one setting pressure
 2 = two setting pressure
 3 = three setting pressure

Valve configuration
 0 = venting with de-energized solenoid
 1 = venting with energized solenoid
 2 = without venting

Max regulated pressure of first (second / third) setting see section 12

(1) Option /BT = low temperature -40°C also available on request

Seals material (1):
 omit for NBR (mineral oil & water glycol)
PE = FPM

Series number

Voltage Code, see section 11

Options:

- E** = external pilot
- O** = horizontal cable entrance
- V** = regulating handwheel
- WP** = prolonged manual override protected by metallic cap
- Y** = external drain

AO/UL = C UL US certification

Solenoid threaded connection:
NPT = 1/2" NPT ANSI B2.1 (tapered)

12 HYDRAULIC CHARACTERISTICS

Valve model	Size 10	Size 20	Size 32
Setting		50; 100; 210; 350	
Max pressure port P [bar]		350	
Pressure range [bar]		4÷50; 6÷100; 7÷210; 8÷350	
Max flow AGAM [l/min]	200	400	600
Max flow ARAM [l/min]	-	350	500

13 MODEL CODE OF COVERS FOR CARTRIDGE VALVES

LIDEW - 1 / NPT - AO/UL - * 24DC ** /*

Cover type:
LIDBH* = with solenoid valve and shuttle valve for pilot selection
LIDEW* = with solenoid valve for pilot selection
 * = valve configuration (see H030 section 2)

Size (ISO 7368)
 1 = 16; 2 = 25; 3 = 32; 4 = 40; 5 = 50; 6 = 63; 8 = 80 (only for LIDEW);

Solenoid threaded connection:
NPT = 1/2" NPT ANSI B2.1 (tapered)

Certification type
AO/UL = C UL US certification

Note: for the code of the ISO cartridge to use with the above covers see tab. H003, section 2 and tab. H030, section 3.

(1) Option /BT = low temperature -40°C also available on request

Optional different provision or setting of the calibrated plugs in the pilot channels see table H030 sect. 3

Seals material (1):
 omit for NBR (mineral oil & water glycol)
PE = FPM

Series number

Voltage code - see section 11

Options:

- B** = cartridge piloted via port "B" of solenoid pilot valve
- E** = external attachments X (1/4" GAS) and underneath port X supplied plugged (only for sizes 40...80)
- O** = horizontal cable entrance
- WP** = prolonged manual override protected by metallic cap

14 HYDRAULIC SYMBOLS

18 MODEL CODE OF SERVOPROPORTIONAL VALVES

DLHZA /UL - T - 0 4 0 - L 7 3 / NPT / * ** /*

DLHZA = size 06
DLKZA = size 10

UL = C UL US certification

T = with integral position transducer

Valve size (ISO 4401)
0 = size 06 (DLHZA)
1 = size 10 (DLKZA)

Configuration, see section 19
4 = spring offset with fail safe
6 = spring offset

Spool overlapping in central position, see section 19
0 = P, A, B, T zero overlapping

Spool type
L = linear; **T** = not linear;

(1) Option **/BT** = low temperature -40°C also available on request

Seals material (1):
omit for NBR (mineral oil & water glycol)
PE = FPM

Series number

Options:
B = solenoid at side of port A
C = position transducer with current feedback 4÷20 mA
Y = external drain

Solenoid threaded connection:
NPT = 1/2" NPT ANSI B2.1 (tapered)

Fail safe configuration:
1 = A, B, P, T with positive overlapping **3** = P, positive overlapping; A, B, T negative

Spool size: see section 19

19 HYDRAULIC CHARACTERISTICS (based on mineral oil ISO VG 46 at 50 °C)

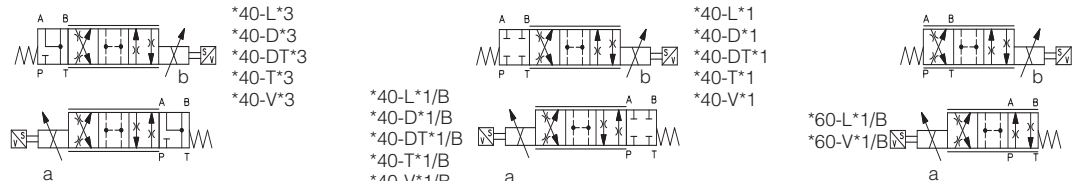
Hydraulic symbols 	<p>DLHZA-T*</p> <p>ports P, A, B = 350; T = 160 (250 with external drain Y)</p> <p>DLKZA-T*</p> <p>ports P, A, B = 315; T = 160 (250 with external drain Y)</p>
Valve model	70
Pressure limits [bar]	60
Δp max P-T	70
Spool	L0 L1 V1 L3 V3 L5 T5 L7 T7 V7 D7 DT7 L3 L7 T7 V7 D7 DT7
Max flow at Δp = 30 bar [l/min]	2,5 4,5 5 9 13 18 26 26÷13 40 65 65÷33
max permissible flow [l/min]	4 7 8 14 20 28 40 40÷20 55 80 80÷40
Leakage [cm³/min] at P = 100 bar (1)	<100 <200 <100 <300 <150 <500 <200 <900 <200 <200 <700 <200 <1000 <1500 <400 <400 <1200 <400
Response time [ms]	≤ 10
Hysteresis [%]	≤ 0,1%
Thermal drift	zero point displacement < 1% at ΔT = 40°C

(1) Referred to spool in center position and 50°C oil temperature.

20 MODEL CODE OF PRESSURE COMPENSATED PROPORTIONAL FLOW CONTROL VALVES

QVHZA / UL - T - 06 / 12 / NPT / * ** /*

QVHZA = size 06
QVKZA = size 10

UL = C UL US certification

A = without position transducer
T = with integral position transducer

Valve size (ISO 4401)
QVHZA: **06** QVKZA: **10**

Max regulated flow:
QVHZA QVKZA
3 = 3,5 l/min; **36** = 36 l/min; **65** = 65 l/min
12 = 12 l/min; **45** = 45 l/min; **90** = 90 l/min
18 = 18 l/min;

(1) Option **/BT** = low temperature -40°C also available on request

Seals material (1):
omit for NBR (mineral oil & water glycol)
PE = FPM

Series number

Omit for standard coil 12 Vdc:
24 = with 24 VDC coils (only A version)

Options:
C = current feedback signal 4÷20 mA (only for -T versions)
D = quick venting
O = horizontal cable entrance (only for -A versions)
WP = prolonged manual override protected by metallic cap (only for valves without transducer)

Solenoid threaded connection:
NPT = 1/2" NPT ANSI B2.1 (tapered)

21 HYDRAULIC CHARACTERISTICS (based on mineral oil ISO VG 46 at 50 °C)

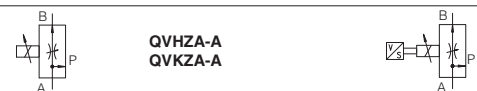
Hydraulic symbols Note: In three-way versions port P is open. In two-way versions port P must be plugged. Port T must always be plugged.	
Valve model	QVHZA-A QVHZA-T QVKZA-A QVKZA-T
Valve size	06 06 10 10
Max pressure ports P, A, B [l/min]	210
Max regulated flow [l/min]	3,5 12 18 36 45 3,5 12 18 35 45 65 90 65 90
Min regulated flow (1) [cm³/min]	15 20 30 50 60 15 20 30 50 60 85 100 85 100
Regulating Δp [bar]	4 - 6 10 - 12 15 4 - 6 10 - 12 15 6 - 8 10 - 12 6 - 8 10 - 12
Max flow on port A [l/min]	40 35 50 55 50 60 70 100 70 100

Above performance data refer to valves coupled with Atos electronic drivers.

(1) Values are referred to 3-way configuration. In the 2-way configuration, the values of min regulated flow are higher

22 MODEL CODE OF PROPORTIONAL PRESSURE RELIEF AND COMPENSATOR VALVES

RZMA / **UL** - **A** - **010** / **250** / **NPT** / * / * / ** / *

Pressure relief:
RZMA = subplate size 06
HZMA = modular size 06
AGMZA = subplate size 10, 20, 32
LIMZA = cartridge (1)
 Pressure compensator:
LICZA = cartridge (1)

UL = C UL US certification

A = without integral pressure transducer

Valve size:
 see section 23 for size code

Max regulated pressure:
 see section 23

(1) For the code of the ISO cartridge to use with LIMZA and LICZA, see tab. F300 section 2.
 (2) Option **/BT** = low temperature -40°C also available on request

Seals material (2):
 omit for NBR (mineral oil & water glycol)
PE = FPM

Series number

Omit for standard coil 12 V_{DC}:
24 = with 24 VDC coils (only A version)

Options:
E = external pilot (only for AGMZA)
O = horizontal cable entrance
P = with integral mechanical pressure limiter (only for L1*ZA)
Y = external drain (only for AGMZA)

Solenoid threaded connection:
NPT = 1/2" NPT ANSI B2.1 (tapered)

23 HYDRAULIC CHARACTERISTICS

Valve model	RZMA			HZMA	AGMZA			LIMZA						LICZA					
Size code	010	030	030		10	20	32	1	2	3	4	5	6	8	1	2	3	4	5
Valve size	06				10	20	32	16	25	32	40	50	63	80	16	25	32	40	50
Max regulated pressure [bar]								80;			180;			250					
Max pressure at port P, A, B, X [bar]								315											
Max pressure at port T, Y [bar]								210											
Max flow [l/min]	4	40	40	200	400	600	200	400	750	1000	2000	3000	4500	200	400	750	1000	2000	

24 MODEL CODE OF PROPORTIONAL PRESSURE REDUCING VALVES

RZGA / **UL** - **A** - **010** / **250** / **NPT** / * / * / ** / *

Pressure reducing:
RZGA = subplate size 06
HZGA = modular size 06
KZGA = modular size 10
AGRCZA = subplate size 10, 20
LIRZA = cartridge

UL = C UL US certification

A = without integral transducer

Valve size:
 see section 25 for size code

Max regulated pressure:
 see section 25

Note: for the code of the ISO cartridge to use with LIRZA, see tab. F300 section 2.
 (1) Option **/BT** = low temperature -40°C also available on request

Seals material (1):
 omit for NBR (mineral oil & water glycol)
PE = FPM

Series number

Omit for standard coil 12 V_{DC}:
24 = with 24 VDC coils (only A version)

Options:
O = horizontal cable entrance (1)
P = with integral mechanical pressure limiter (only for AGRCZA and LIRZA)
R = with check valve (only for AGRCZA)

Solenoid threaded connection:
NPT = 1/2" NPT ANSI B2.1 (tapered)

25 HYDRAULIC CHARACTERISTICS

Valve model	RZGA			HZGA	KZGA	AGRCZA		LIRZA			
Size code	010	033	031	031	031	10	20	1	2	3	4
Valve size	06				10	10	20	16	25	32	40
Max regulated pressure [bar]	32; 100; 210				80;			250			
Min regulated pressure [bar]	0,8	1	1	1	1	1	7	7	7	7	7
Max pressure at port P [bar]	315										
Max pressure at port T [bar]	210										
Max flow [l/min]	12	40	40	100	160	300	160	300	550	800	

**OAUL
OZAUL-A**

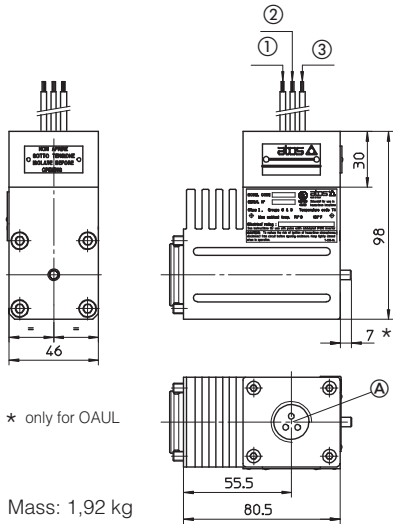

OZAUL-T

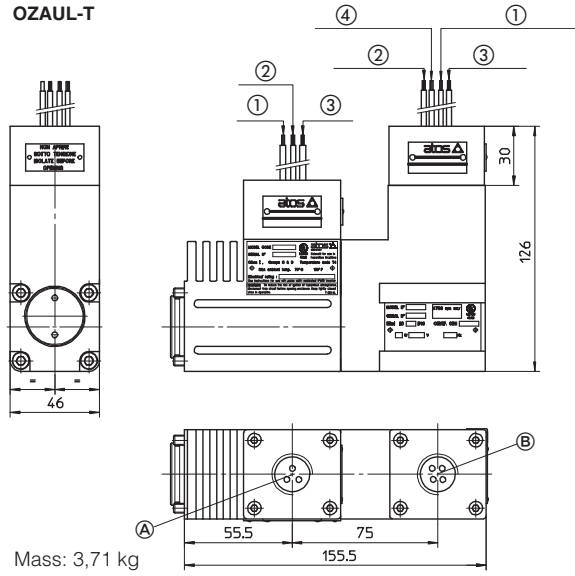

Option /WP

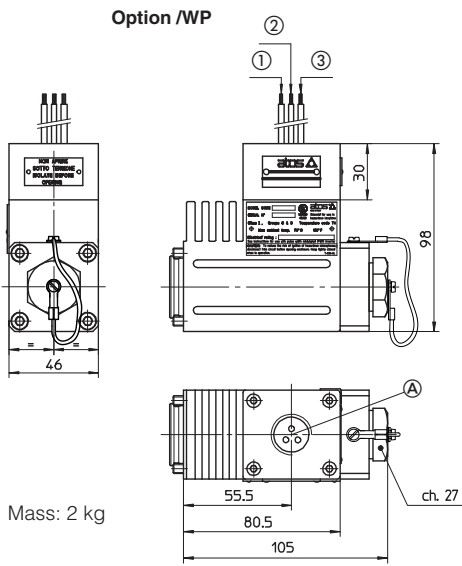

Option /O

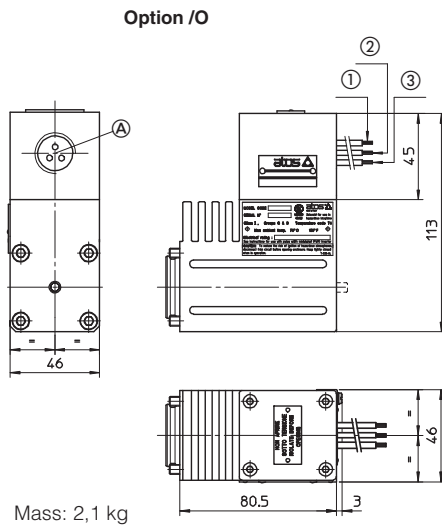

Option /OWP

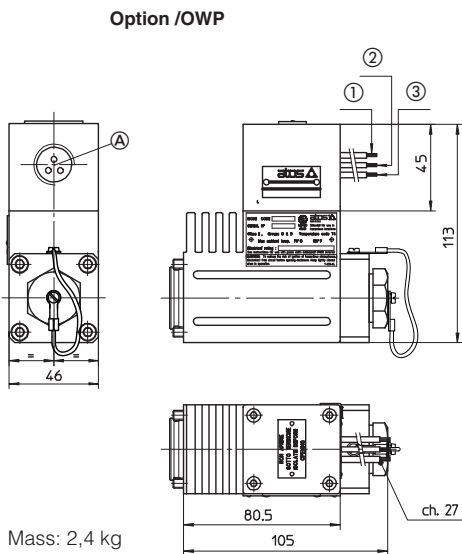

Option /MV

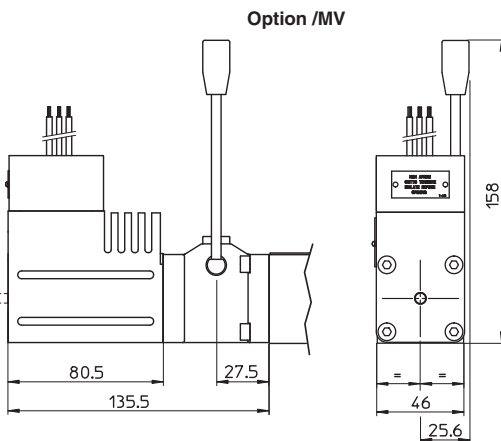

(A) Solenoid wiring (connection 1/2" NPT)

Solenoid OAUL		AC	DC	Solenoid OZAUL	
①	Coil	white	red = +	①	Coil red
②	GND	green	green	②	GND green
③	Coil	black	black = -	③	Coil black

(B) Position transducer wiring (connection 1/2" NPT)

①	Output signal	white
②	Supply -15V	black
③	Supply +15V	red
④	GND	yellow

The valves are supplied with 1 m (42 inches) cable length, factory wired.

Wire AVL2 UL Listed AWG16, 120° /300 V

Power supply: section = 1,2 mm²

Grounding: section = 1,2 mm²