

# Digital proportional relief valves

direct, without transducer

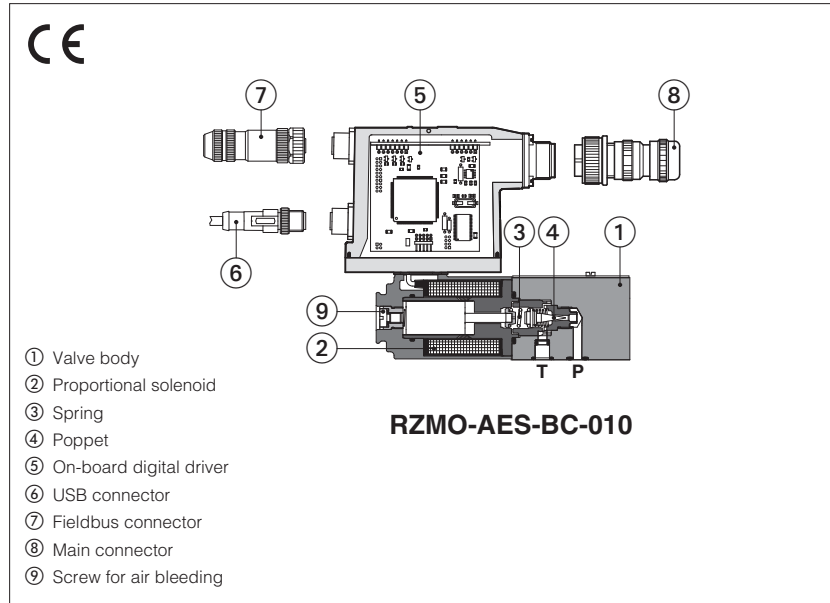

## RZMO-A , RZMO-AEB, RZMO-AES

Poppet type, direct, digital proportional relief valves for pressure open loop controls.

**A** to be coupled with off-board driver.

**AEB** basic execution, with on-board digital driver, with analog reference signal or IO-Link interface for digital reference signal, valve settings, and real-time diagnostics.

**AES** full execution, with on-board digital driver which includes also fieldbus interfaces for digital reference signal, valve settings, and real-time diagnostics.

For **AEB** and **AES**, USB port is always present for valve settings via Atos PC software.

Size: **06** - ISO 4401

Max flow: **4 l/min**

Max pressure: **350 bar**

## 1 MODEL CODE

<b>RZMO</b>	-	<b>AEB</b>	-	<b>NP</b>	-	<b>010</b>	/	<b>210</b>	/	*	/	*	/	*	/	*
<p>Proportional pressure relief valve, direct</p> <p><b>A</b> = off-board driver, see section 3  <b>AEB</b> = basic on-board digital driver  <b>AES</b> = full on-board digital driver</p> <p><b>IO-Link interface</b>, only for AEB, see section 6:  <b>NP</b> = Not present    <b>IL</b> = IO-Link</p> <p><b>Fieldbus interfaces</b>, only for AES, see section 7:  <b>BC</b> = CANopen    <b>EH</b> = EtherCAT  <b>BP</b> = PROFIBUS DP</p> <p><b>Configuration:</b>  <b>010</b> = regulation on port P, discharge in T (direct operated version)</p>																
<p><b>Seals material</b>, see section 11:  - = NBR  <b>PE</b> = FKM  <b>BT</b> = NBR low temp.</p> <p>Series number</p> <p><b>Coil voltage</b>, only for <b>A</b> - see section 15:  - = standard coil for 24VDC Atos drivers  <b>6</b> = optional coil for 12VDC Atos drivers  <b>18</b> = optional coil for low current drivers</p> <p><b>Electronic options</b>, only for <b>AEB-NP</b> and <b>AES (1)</b>:  <b>I</b> = current reference input 4÷20 mA (omit for std voltage 0÷10 VDC)  <b>Q</b> = enable signal  <b>Z</b> = double power supply, enable, fault and monitor signals -12 pin connector</p>																
<p><b>Max regulated pressure (2):</b>  <b>50</b> = 50 bar    <b>210</b> = 210 bar    <b>350</b> = 350 bar  <b>100</b> = 100 bar    <b>315</b> = 315 bar</p>																

(1) Possible combined options: IQ, IZ  
(2) Special execution with max regulated pressure **500 bar** available on request

## 2 HYDRAULIC SYMBOLS

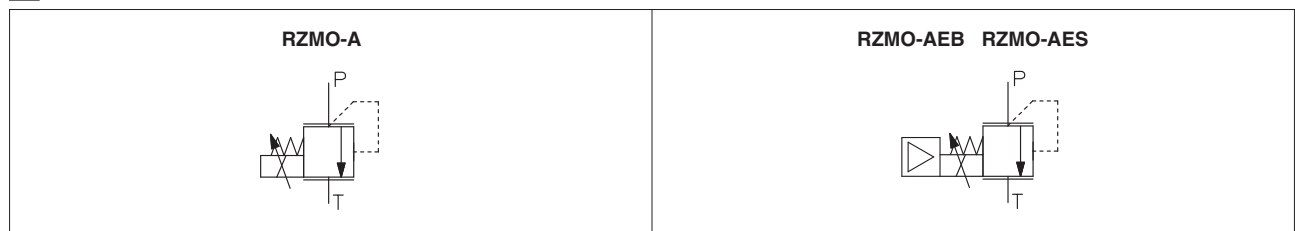

### 3 OFF-BOARD ELECTRONIC DRIVERS - only for A

Drivers model	E-MI-AC-01F		E-MI-AS-IR		E-BM-AS-PS		E-BM-AES
Type	Analog				Digital		
Voltage supply (VDC)	12	24	12	24	12	24	24
Valve coil option	/6	std	/6	std	/6	std	std
Format	plug-in to solenoid				DIN-rail panel		
Tech table	G010		G020		G030		GS050

### 4 GENERAL NOTES

Atos digital proportionals valves are CE marked according to the applicable directives (e.g. Immunity and Emission EMC Directive). Installation, wirings and start-up procedures must be performed according to the general prescriptions shown in tech table **FS900** and in the user manuals included in the E-SW-\* programming software.

### 5 VALVE SETTINGS AND PROGRAMMING TOOLS

Valve's functional parameters and configurations, can be easily set and optimized using Atos E-SW programming software connected via USB/Bluetooth to the digital driver. For fieldbus/IO-Link versions, the software permits valve's parameterization through USB/Bluetooth also if the driver is connected to the central machine unit via fieldbus/IO-Link.

The software is available in different versions according to the driver's options (see table **GS500**):

**E-SW-BASIC** support: NP (USB) IL (IO-Link) PS (Serial) IR (Infrared)

**E-SW-FIELDBUS** support: BC (CANopen) BP (PROFIBUS DP) EH (EtherCAT)  
EW (POWERLINK) EI (EtherNet/IP) EP (PROFINET)

**E-SW-\*/PQ** support: valves with SP, SF, SL alternated control (e.g. E-SW-BASIC/PQ)



**WARNING: drivers USB port is not isolated!** For E-C-SB-USB/M12 cable, the use of isolator adapter is highly recommended for PC protection



**WARNING:** see tech table **GS500** for the list of countries where the Bluetooth adapter has been approved

#### USB or Bluetooth connection

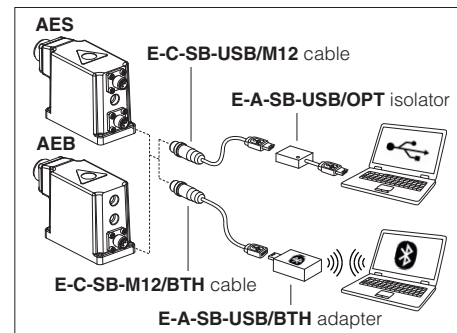

### 6 IO-LINK - only for AEB, see tech. table GS520

IO-Link allows low cost digital communication between the valve and machine central unit. The valve is directly connected to a port of an IO-Link master (point-to-point connection) via low-cost unshielded cables for digital reference, diagnostic and settings. The IO-Link master works as a hub exchanging this information with the machine central unit via fieldbus.

### 7 FIELDBUS - only for AES, see tech. table GS510

Fieldbus allows valve direct communication with machine control unit for digital reference, valve diagnostics and settings. These execution allow to operate the valves through fieldbus or analog signals available on the main connector.

### 8 GENERAL CHARACTERISTICS

Assembly position	Any position
Subplate surface finishing to ISO 4401	Acceptable roughness index: $Ra \leq 0,8$ , recommended $Ra 0,4$ – Flatness ratio 0,01/100
MTTFd valves according to EN ISO 13849	150 years, for further details see technical table P007
Ambient temperature range	<b>A:</b> Standard = $-20^{\circ}\text{C} \div +70^{\circ}\text{C}$ /PE option = $-20^{\circ}\text{C} \div +70^{\circ}\text{C}$ /BT option = $-40^{\circ}\text{C} \div +60^{\circ}\text{C}$ <b>AEB, AES:</b> Standard = $-20^{\circ}\text{C} \div +60^{\circ}\text{C}$ /PE option = $-20^{\circ}\text{C} \div +60^{\circ}\text{C}$ /BT option = $-40^{\circ}\text{C} \div +60^{\circ}\text{C}$
Storage temperature range	<b>A:</b> Standard = $-20^{\circ}\text{C} \div +80^{\circ}\text{C}$ /PE option = $-20^{\circ}\text{C} \div +80^{\circ}\text{C}$ /BT option = $-40^{\circ}\text{C} \div +70^{\circ}\text{C}$ <b>AEB, AES:</b> Standard = $-20^{\circ}\text{C} \div +70^{\circ}\text{C}$ /PE option = $-20^{\circ}\text{C} \div +70^{\circ}\text{C}$ /BT option = $-40^{\circ}\text{C} \div +70^{\circ}\text{C}$
Surface protection	Zinc coating with black passivation, galvanic treatment (driver housing for AEB and AES)
Corrosion resistance	Salt spray test (EN ISO 9227) > 200 h
Vibration resistance	See technical table G004 (for AEB and AES)
Compliance	CE according to EMC directive 2014/30/EU (Immunity: EN 61000-6-2; Emission: EN 61000-6-3) RoHS Directive 2011/65/EU as last update by 2015/863/EU REACH Regulation (EC) n°1907/2006

**9 HYDRAULIC CHARACTERISTICS** - based on mineral oil ISO VG 46 at 50 °C

Valve model	<b>RZMO-*-010</b>	
Max regulated pressure [bar]	50; 100; 210; 315; 350	
Max pressure at port P [bar]	350	
Max pressure at port T [bar]	210	
Min regulated pressure [bar]	see min. pressure / flow diagram at section <a href="#">12</a>	
Max flow [l/min]	4	
Response time 0-100% step signal (depending on installation) <b>(1)</b> [ms]	≤ 70	
Hysteresis	≤ 1,5 [% of max pressure]	
Linearity	≤ 3,0 [% of max pressure]	
Repeatability	≤ 2,0 [% of max pressure]	

**Note:** above performance data refer to valves coupled with Atos electronic drivers, see section [3](#)

**(1)** Average response time value; the pressure variation in consequence of a modification of the reference input signal to the valve is affected by the stiffness of the hydraulic circuit: greater is the stiffness of the circuit, faster is the dynamic response

**10 ELECTRICAL CHARACTERISTICS**

Power supplies	Nominal : +24 VDC Rectified and filtered : VRMS = 20 ÷ 32 VMAX (ripple max 10 % VPP)				
Max power consumption	<b>A</b> = 30 W <b>AEB, AES</b> = 50 W				
Coil voltage code	standard	option /6	option /18		
Max. solenoid current	2,6 A	3,25 A	1,5 A		
Coil resistance R at 20°C	3 ÷ 3,3 Ω	2 ÷ 2,2 Ω	13 ÷ 13,4 Ω		
Analog input signals	Voltage: range ±10 VDC (24 VMAX tolerant) Current: range ±20 mA		Input impedance: Ri > 50 kΩ Input impedance: Ri = 500 Ω		
Monitor output	Output range: voltage ±5 VDC @ max 5 mA				
Enable input	Range: 0 ÷ 9 VDC (OFF state), 15 ÷ 24 VDC (ON state), 9 ÷ 15 VDC (not accepted); Input impedance: Ri > 87 kΩ				
Fault output	Output range : 0 ÷ 24 VDC (ON state ≡ VL+ [logic power supply] ; OFF state ≡ 0 V) @ max 50 mA; external negative voltage not allowed (e.g. due to inductive loads)				
Alarms	Solenoid not connected/short circuit, cable break with current reference signal, over/under temperature, current control monitoring, power supplies level				
Insulation class	H (180°) Due to the occurring surface temperatures of the solenoid coils, the European standards ISO 13732-1 and EN982 must be taken into account				
Protection degree to DIN EN60529	<b>A</b> = IP65; <b>AEB, AES</b> = IP66 / IP67 with mating connectors				
Duty factor	Continuous rating (ED=100%)				
Tropicalization	Tropical coating on electronics PCB				
Additional characteristics	Short circuit protection of solenoid's current supply; current control by P.I.D. with rapid solenoid switching; protection against reverse polarity of power supply				
Communication interface	USB Atos ASCII coding	IO-Link Interface and System Specification 1.1.3	CANopen EN50325-4 + DS408	PROFIBUS DP EN50170-2/IEC61158	EtherCAT IEC 61158
Communication physical layer	not insulated USB 2.0+ USB OTG	SDCI class port B	optical insulated CAN ISO11898	optical insulated RS485	Fast Ethernet, insulated 100 Base TX
Recommended wiring cable	LIYCY shielded cables, see section <a href="#">20</a>				

**Note:** a maximum time of 500 ms (depending on communication type) has to be considered between the driver energizing with the 24 VDC power supply and when the valve is ready to operate. During this time the current to the valve coils is switched to zero.

**11 SEALS AND HYDRAULIC FLUIDS** - for other fluids not included in below table, consult our technical office

Seals, recommended fluid temperature	NBR seals (standard) = -20°C ÷ +60°C (+80°C for <b>A</b> ), with HFC hydraulic fluids = -20°C ÷ +50°C FKM seals (/PE option) = -20°C ÷ +80°C NBR low temp. seals (/BT option) = -40°C ÷ +60°C, with HFC hydraulic fluids = -20°C ÷ +50°C		
Recommended viscosity	20 ÷ 100 mm <sup>2</sup> /s - max allowed range 15 ÷ 380 mm <sup>2</sup> /s		
Max fluid contamination level	normal operation	ISO4406 class 18/16/13    NAS1638 class 7	see also filter section at
	longer life	ISO4406 class 16/14/11    NAS1638 class 5	www.atos.com or KTF catalog
<b>Hydraulic fluid</b>	<b>Suitable seals type</b>	<b>Classification</b>	<b>Ref. Standard</b>
Mineral oils	NBR, FKM, NBR low temp.	HL, HLP, HLPD, HVLP, HVLDP	DIN 51524
Flame resistant without water	FKM	HF DU, HF DR	ISO 12922
Flame resistant with water	NBR, NBR low temp.	HFC	

**12 DIAGRAMS** (based on mineral oil ISO VG 46 at 50 °C)

**1 Regulation diagrams**  
with flow rate Q = 1 l/min

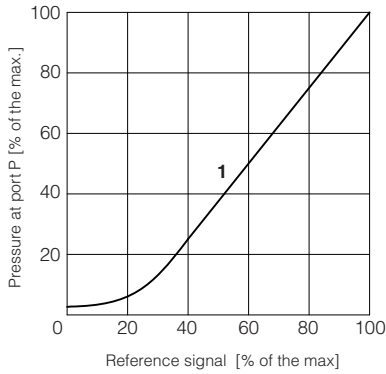

**2 Pressure/flow diagrams**  
with reference signal set at Q = 1 l/min

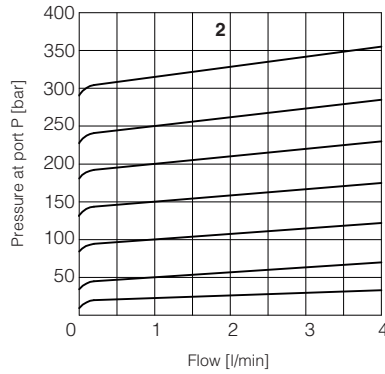

**3-6 Min. pressure/flow diagrams**  
with zero reference signal

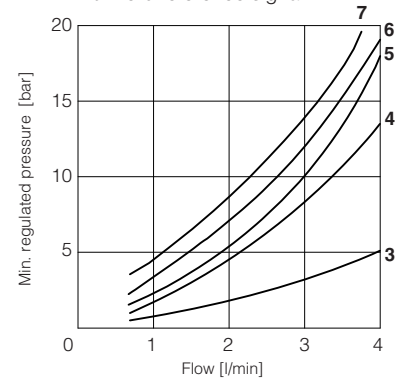

**3** = RZMO/50      **4** = RZMO/100  
**5** = RZMO/210    **6** = RZMO/315  
**7** = RZMO/350

**Note:** the presence of counter pressure at port T can affect the pressure regulation and the minimum pressure

**13 ELECTRONIC OPTIONS** - only for **AEB-NP** and **AES**

- I** = This option provides 4 ÷ 20 mA current reference and monitor signals, instead of the standard 0 ÷ 10 VDC. Input signal can be reconfigured via software selecting between voltage and current, within a maximum range of ±10 VDC or ±20 mA. It is normally used in case of long distance between the machine control unit and the valve or where the reference signal can be affected by electrical noise; the valve functioning is disabled in case of reference signal cable breakage.
- Q** = This option permits to inhibit the valve function without removing the power supply to the driver. Upon disable command the current to the solenoid is zeroed and the valve's spool moves to rest position. The option /Q is suggested for all cases where the valve has to be frequently inhibited during the machine cycle – see 17.5 for signal specifications.
- Z** = This option provides, on the 12 pin main connector, the following additional features:  
**Fault output signal** - see 17.6  
**Enable input signal** - see above option /Q  
**Power supply for driver's logics and communication** - see 17.2

**14 POSSIBLE COMBINED OPTIONS**

**Electronics options:** /IQ, /IZ

**15 COIL VOLTAGE OPTIONS** - only for **A**

- 6** = Optional coil to be used with Atos drivers with power supply 12 Vdc.
- 18** = Optional coil to be used with electronic drivers not supplied by Atos.

**16 AIR BLEEDING**

At the first valve commissioning the air eventually trapped inside the solenoid must be bled-off through the screw ① located at the rear side of the solenoid housing. The presence of air may cause pressure instability and vibrations.

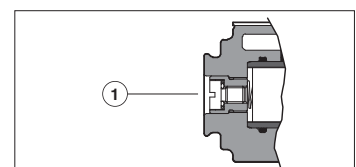

## 17 POWER SUPPLY AND SIGNALS SPECIFICATIONS - only for AEB-NP and AES

Generic electrical output signals of the valve (e.g. fault or monitor signals) must not be directly used to activate safety functions, like to switch-ON/OFF the machine's safety components, as prescribed by the European standards (Safety requirements of fluid technology systems and components-hydraulics, ISO 4413).

For AEB-IL signals see section 18

### 17.1 Power supply (V+ and V0)

The power supply must be appropriately stabilized or rectified and filtered: apply at least a 10000  $\mu$ F/40 V capacitance to single phase rectifiers or a 4700  $\mu$ F/40 V capacitance to three phase rectifiers. In case of separate power supply see 17.2.



A safety fuse is required in series to each power supply: 2,5 A time lag fuse.

### 17.2 Power supply for driver's logic and communication (VL+ and VL0) - only for /Z option

The power supply for driver's logic and communication must be appropriately stabilized or rectified and filtered: apply at least a 10000  $\mu$ F/40 V capacitance to single phase rectifiers or a 4700  $\mu$ F/40 V capacitance to three phase rectifiers.

The separate power supply for driver's logic on pin 9 and 10, allow to remove solenoid power supply from pin 1 and 2 maintaining active the diagnostics, USB and fieldbus communications.



A safety fuse is required in series to each driver's logic and communication power supply: 500 mA fast fuse.

### 17.3 Reference input signal (INPUT+)

The driver controls in closed loop the current to the valve proportionally to the external reference input signal.

Reference input signal is factory preset according to selected valve code, defaults are 0  $\div$  10 V<sub>DC</sub> for standard and 4  $\div$  20 mA for /I option.

Input signal can be reconfigured via software selecting between voltage and current, within a maximum range of  $\pm$ 10 V<sub>DC</sub> or  $\pm$  20 mA.

Drivers with fieldbus interface (BC, BP, EH) can be software set to receive reference signal directly from the machine control unit (fieldbus reference). Analog reference input signal can be used as on-off commands with input range 0  $\div$  24V<sub>DC</sub>.

### 17.4 Monitor output signal (MONITOR)

The driver generates an analog output signal (MONITOR) proportional to the actual coil current of the valve; the monitor output signal can be software set to show other signals available in the driver (e.g. analog reference, fieldbus reference).

Monitor output signal is factory preset according to selected valve code, default settings is  $\pm$ 5 V<sub>DC</sub> (1V = 1A).

Output signal can be reconfigured via software, within a maximum range of 0  $\div$  5 V<sub>DC</sub>.

### 17.5 Enable input signal (ENABLE) - not for standard

To enable the driver, supply a 24 V<sub>DC</sub> on pin 3 (pin C): Enable input signal allows to enable/disable the current supply to the solenoid, without removing the electrical power supply to the driver; it is used to active the communication and the other driver functions when the valve must be disabled for safety reasons. This condition **does not comply** with norms IEC 61508 and ISO 13849.

Enable input signal can be used as generic digital input by software selection.

### 17.6 Fault output signal (FAULT) - only for /Z option

Fault output signal indicates fault conditions of the driver (solenoid short circuits/not connected, reference signal broken for 4  $\div$  20 mA input, etc.).

Fault presence corresponds to 0 V<sub>DC</sub>, normal working corresponds to 24 V<sub>DC</sub>.

Fault status is not affected by the Enable input signal.

## 18 IO-LINK SIGNALS SPECIFICATIONS - only for AEB-IL

### 18.1 Power supply for IO-Link communication (L+ and L-)

The IO-Link master provides dedicated 24 VDC power supply for IO-Link communication.

Maximum power consumption: 2 W

Internal electrical isolation of power L+, L- from P24, N24

### 18.2 Power supply for driver's logic and valve regulation (P24 and N24)

The IO-Link master provides dedicated 24 VDC power supply for valve regulation, logics and diagnostics.

Maximum power consumption: 50 W

Internal electrical isolation of power P24, N24 from L+, L-

### 18.3 IO-Link data line (C/Q)

C/Q signal is used to establish communication between IO-Link master and valve.

## 19 ELECTRONIC CONNECTIONS

### 19.1 Main connector signals - 7 pin (A1) Standard and /Q option - for AEB-NP and AES

PIN	Standard	/Q	TECHNICAL SPECIFICATIONS	NOTES
A	V+		Power supply 24 Vdc	Input - power supply
B	V0		Power supply 0 Vdc	Gnd - power supply
C	AGND		Analog ground	Gnd - analog signal
		ENABLE	Enable (24 Vdc) or disable (0 Vdc) the driver, referred to V0	Input - on/off signal
D	INPUT+		Reference input signal: $\pm 10$ Vdc / $\pm 20$ mA maximum range Defaults are $\pm 10$ Vdc for standard and $4 \div 20$ mA for /I option	Input - analog signal <b>Software selectable</b>
E	INPUT-		Negative reference input signal for INPUT+	Input - analog signal
F	MONITOR referred to: AGND   V0		Monitor output signal: $\pm 5$ Vdc maximum range Default is $\pm 5$ Vdc (1V = 1A)	Output - analog signal <b>Software selectable</b>
G	EARTH		Internally connected to driver housing	

### 19.2 Main connector signals - 12 pin (A2) /Z option - for AEB-NP and AES

PIN	/Z	TECHNICAL SPECIFICATIONS	NOTES
1	V+	Power supply 24 Vdc	Input - power supply
2	V0	Power supply 0 Vdc	Gnd - power supply
3	ENABLE	Enable (24 Vdc) or disable (0 Vdc) the driver, referred to VL0	Input - on/off signal
4	INPUT+	Reference input signal: $\pm 10$ Vdc / $\pm 20$ mA maximum range Defaults are $0 \div 10$ Vdc for standard and $4 \div 20$ mA for /I option	Input - analog signal <b>Software selectable</b>
5	INPUT-	Negative reference input signal for INPUT+	Input - analog signal
6	MONITOR	Monitor output signal: $\pm 5$ Vdc maximum range, referred to VL0 Default is $0 \div 5$ Vdc (1V = 1A)	Output - analog signal <b>Software selectable</b>
7	NC	Do not connect	
8	NC	Do not connect	
9	VL+	Power supply 24 Vdc for driver's logic and communication	Input - power supply
10	VL0	Power supply 0 Vdc for driver's logic and communication	Gnd - power supply
11	FAULT	Fault (0 Vdc) or normal working (24 Vdc), referred to VL0	Output - on/off signal
PE	EARTH	Internally connected to driver housing	

**Note:** do not disconnect VL0 before VL+ when the driver is connected to PC USB port

### 19.3 IO-Link connector signals - M12 - 5 pin - Coding A, port class B (A) only for AEB-IL

PIN	SIGNAL	TECHNICAL SPECIFICATIONS	NOTES
1	L+	Power supply 24 Vdc for IO-Link communication	Input - power supply
2	P24	Power supply 24 Vdc for valve regulation, logics and diagnostics	Input - power supply
3	L-	Power supply 0 Vdc for IO-Link communication	Gnd - power supply
4	C/Q	IO-Link data line	Input / Output - signal
5	N24	Power supply 0 Vdc for valve regulation, logics and diagnostics	Gnd - power supply

**Note:** L+, L- and P24, N24 are electrically isolated

### 19.4 Communication connectors - for AEB (B) and AES (B) - (C)

(B) USB connector - M12 - 5 pin always present		
PIN	SIGNAL	TECHNICAL SPECIFICATION (1)
1	+5V_USB	Power supply
2	ID	Identification
3	GND_USB	Signal zero data line
4	D-	Data line -
5	D+	Data line +

(C1) BC fieldbus execution, connector - M12 - 5 pin (2)		
PIN	SIGNAL	TECHNICAL SPECIFICATION (1)
1	CAN_SHLD	Shield
2	NC	do not connect
3	CAN_GND	Signal zero data line
4	CAN_H	Bus line (high)
5	CAN_L	Bus line (low)

(C2) BP fieldbus execution, connector - M12 - 5 pin (2)		
PIN	SIGNAL	TECHNICAL SPECIFICATION (1)
1	+5V	Termination supply signal
2	LINE-A	Bus line (high)
3	DGND	Data line and termination signal zero
4	LINE-B	Bus line (low)
5	SHIELD	

(C3) (C4) EH fieldbus execution, connector - M12 - 4 pin (2)		
PIN	SIGNAL	TECHNICAL SPECIFICATION (1)
1	TX+	Transmitter
2	RX+	Receiver
3	TX-	Transmitter
4	RX-	Receiver
Housing	SHIELD	

(1) Shield connection on connector's housing is recommended

(2) Only for AES execution

### 19.5 Solenoid connection - only for A

PIN	SIGNAL	TECHNICAL SPECIFICATION	Connector code 666
1	COIL	Power supply	
2	COIL	Power supply	
3	GND	Ground	

## 19.6 AEB-NP connections layout

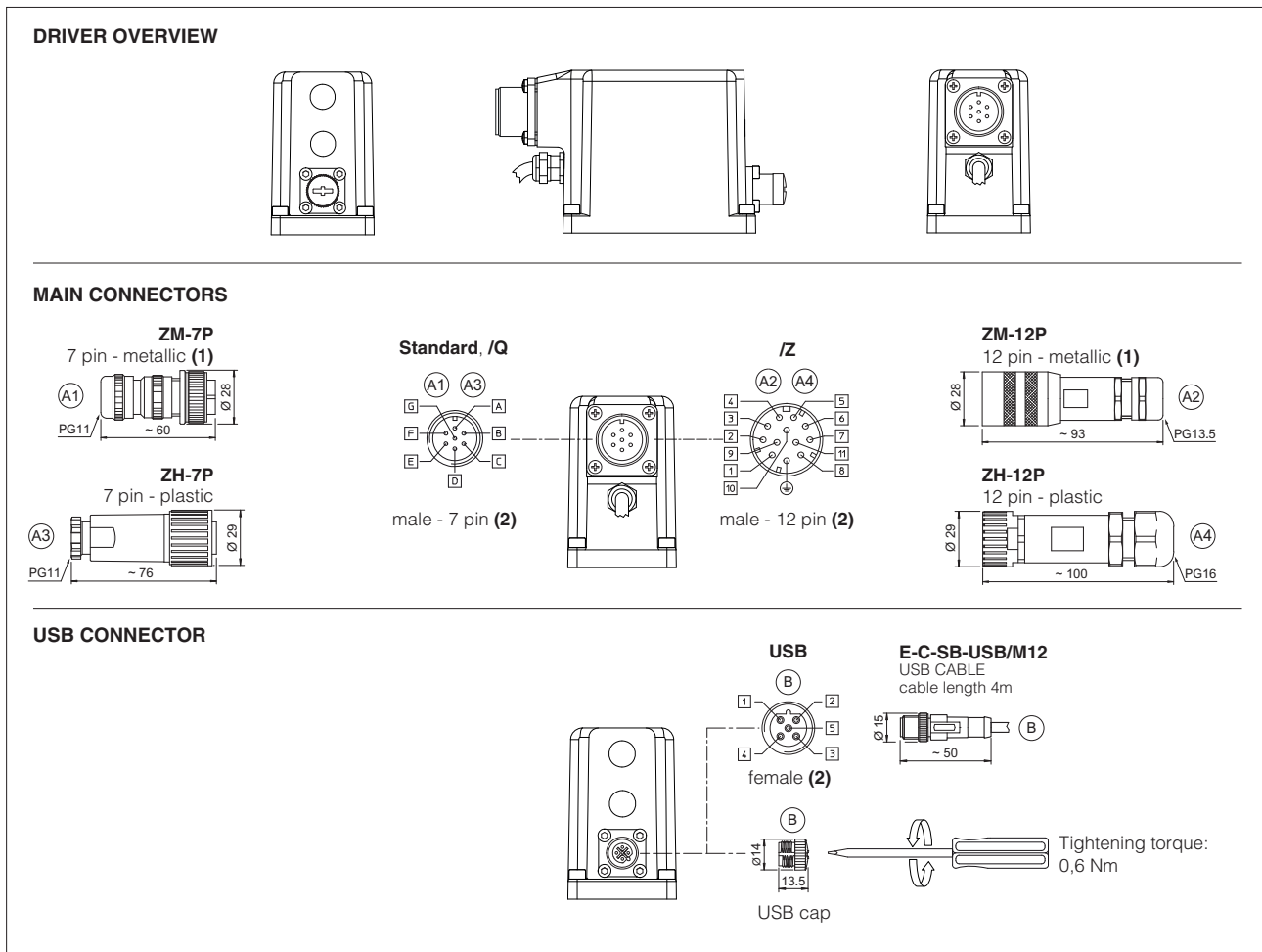

(1) Use of metallic connectors is strongly recommended in order to fulfill EMC requirements (2) Pin layout always referred to driver's view

## 19.7 AEB-IL connections layout

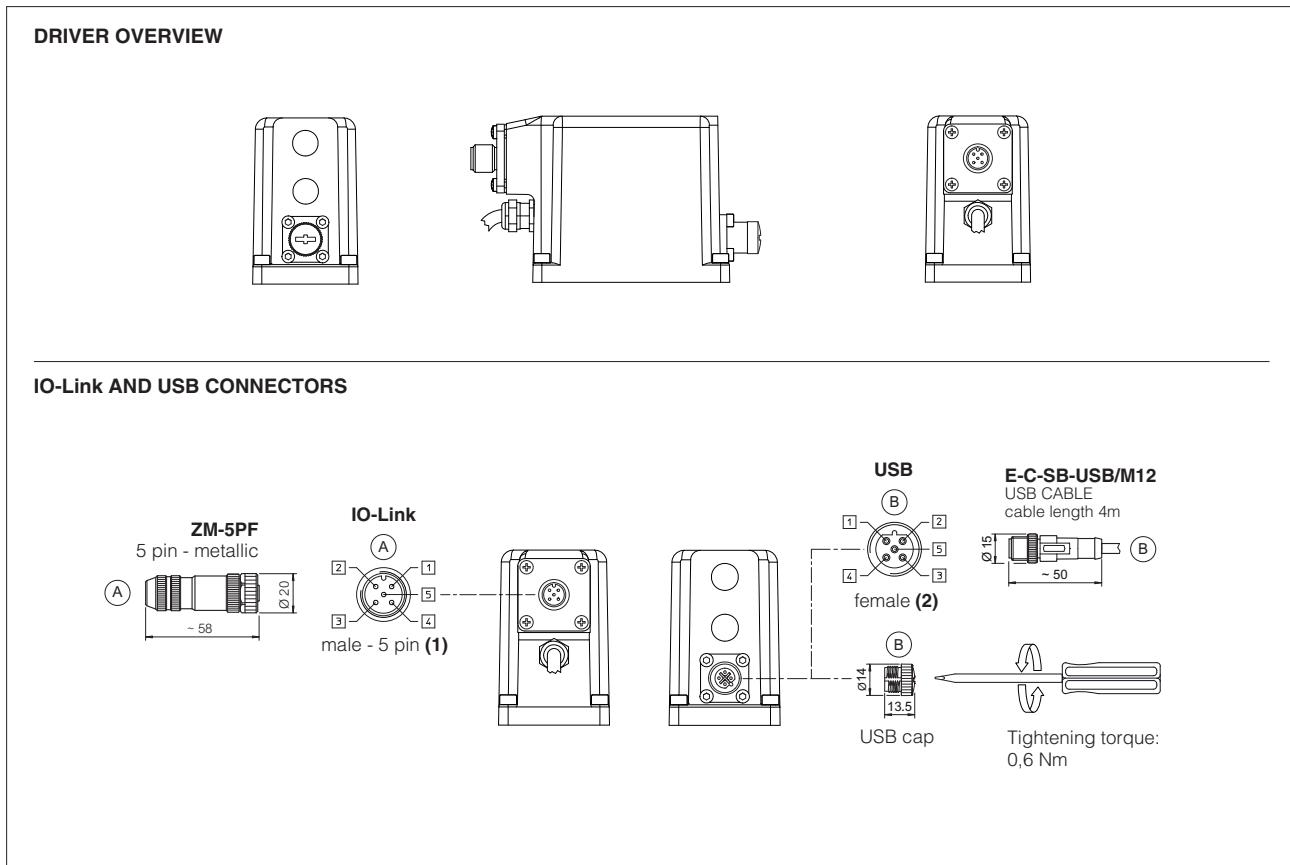

(1) Use of metallic connectors is strongly recommended in order to fulfill EMC requirements (2) Pin layout always referred to driver's view

19.8 AES connections layout

DRIVER OVERVIEW

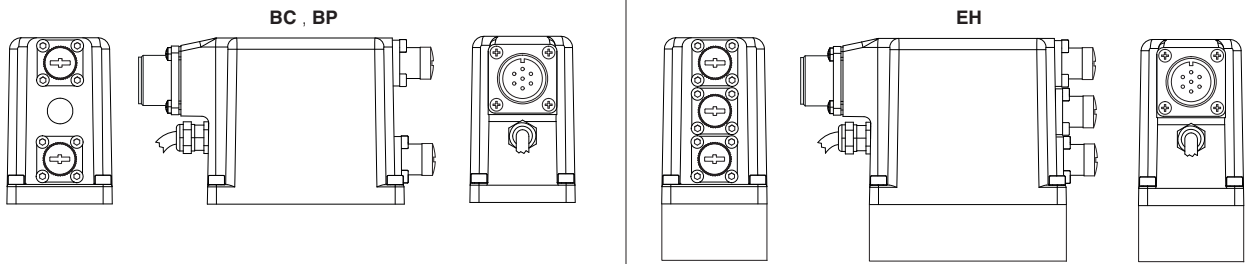

MAIN CONNECTORS

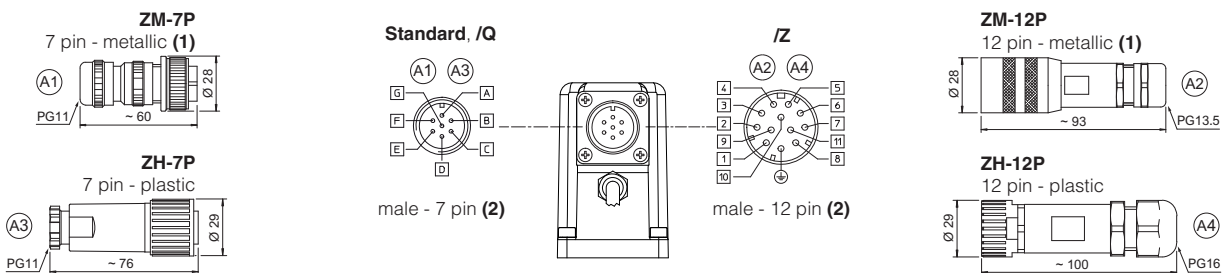

FIELDBUS CONNECTORS

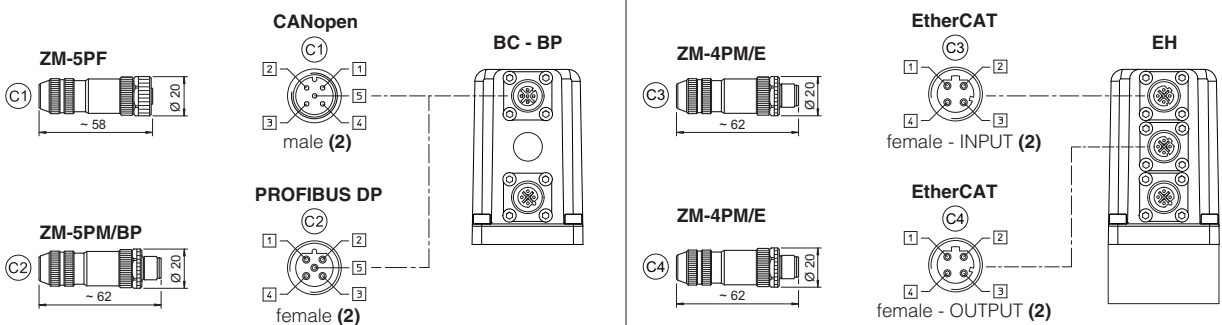

USB CONNECTOR

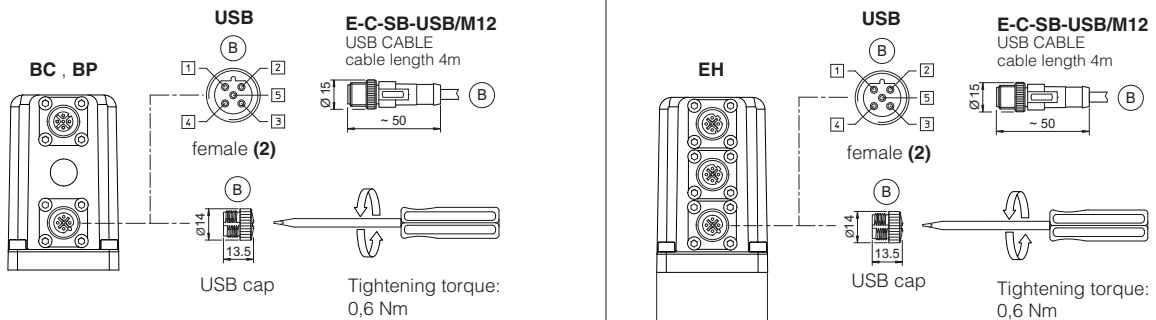

(1) Use of metallic connectors is strongly recommended in order to fulfill EMC requirements (2) Pin layout always referred to driver's view



**20 CONNECTORS CHARACTERISTICS** - to be ordered separately

**20.1 Main connectors - 7 pin - for AEB-NP and AES**

CONNECTOR TYPE	POWER SUPPLY AND SIGNALS	POWER SUPPLY AND SIGNALS
<b>CODE</b>	<b>(A1) ZM-7P</b>	<b>(A3) ZH-7P</b>
Type	7pin female straight circular	7pin female straight circular
Standard	According to MIL-C-5015	According to MIL-C-5015
Material	Metallic	Plastic reinforced with fiber glass
Cable gland	PG11	PG11
Recommended cable	LiYCY 7 x 0,75 mm <sup>2</sup> max 20 m (logic and power supply) or LiYCY 7 x 1 mm <sup>2</sup> max 40 m (logic and power supply)	LiYCY 7 x 0,75 mm <sup>2</sup> max 20 m (logic and power supply) or LiYCY 7 x 1 mm <sup>2</sup> max 40 m (logic and power supply)
Conductor size	up to 1 mm <sup>2</sup> - available for 7 wires	up to 1 mm <sup>2</sup> - available for 7 wires
Connection type	to solder	to solder
Protection (EN 60529)	IP 67	IP 67

**20.2 Main connectors - 12 pin - for AEB-NP and AES**

CONNECTOR TYPE	POWER SUPPLY AND SIGNALS	POWER SUPPLY AND SIGNALS
<b>CODE</b>	<b>(A2) ZM-12P</b>	<b>(A4) ZH-12P</b>
Type	12pin female straight circular	12pin female straight circular
Standard	DIN 43651	DIN 43651
Material	Metallic	Plastic reinforced with fiber glass
Cable gland	PG13,5	PG16
Recommended cable	LiYCY 12 x 0,75 mm <sup>2</sup> max 20 m (logic and power supply)	LiYCY 10 x 0,14mm <sup>2</sup> max 40 m (logic) LiYY 3 x 1mm <sup>2</sup> max 40 m (power supply)
Conductor size	0,5 mm <sup>2</sup> to 1,5 mm <sup>2</sup> - available for 12 wires	0,14 mm <sup>2</sup> to 0,5 mm <sup>2</sup> - available for 9 wires 0,5 mm <sup>2</sup> to 1,5 mm <sup>2</sup> - available for 3 wires
Connection type	to crimp	to crimp
Protection (EN 60529)	IP 67	IP 67

**20.3 IO-Link connector - only for AEB-IL**

CONNECTOR TYPE	IL IO-Link
<b>CODE</b>	<b>(A) ZM-5PF</b>
Type	5pin female straight circular
Standard	M12 coding A – IEC 61076-2-101
Material	Metallic
Cable gland	Pressure nut - cable diameter 6÷8 mm
Recommended cable	5 x 0,75 mm <sup>2</sup> max 20 m
Connection type	screw terminal
Protection (EN 60529)	IP 67



**20.4 Fieldbus communication connectors - only for AES**

CONNECTOR TYPE	BC CANopen (1)		BP PROFIBUS DP (1)		EH EtherCAT (2)
<b>CODE</b>	<b>(C1) ZM-5PF</b>	<b>(C2) ZM-5PM</b>	<b>(C1) ZM-5PF/BP</b>	<b>(C2) ZM-5PM/BP</b>	<b>(C1) (C2) ZM-4PM/E</b>
Type	5 pin female straight circular	5 pin male straight circular	5 pin female straight circular	5 pin male straight circular	4 pin male straight circular
Standard	M12 coding A – IEC 61076-2-101		M12 coding B – IEC 61076-2-101		M12 coding D – IEC 61076-2-101
Material	Metallic		Metallic		Metallic
Cable gland	Pressure nut - cable diameter 6÷8 mm		Pressure nut - cable diameter 6÷8 mm		Pressure nut - cable diameter 4÷8 mm
Cable	CANbus Standard (DR 303-1)		PROFIBUS DP Standard		Ethernet standard CAT-5
Connection type	screw terminal		screw terminal		terminal block
Protection (EN 60529)	IP67		IP 67		IP 67

(1) E-TRM-\*\* terminators can be ordered separately - see tech table **GS500**

(2) Internally terminated

**21 FASTENING BOLTS AND SEALS**

	<p><b>Fastening bolts:</b></p> <p>4 socket head screws M5x50 class 12.9 Tightening torque = 8 Nm</p>
	<p><b>Seals:</b></p> <p>2 OR 108 Diameter of ports P, T: Ø 5 mm</p>

22 INSTALLATION DIMENSIONS [mm]

ISO 4401: 2005

Mounting surface: 4401-03-02-0-05 (see table P005)  
(without ports A and B)

Mass [kg]		
A	AEB, AES	AES-EH
1,8	2,3	2,4

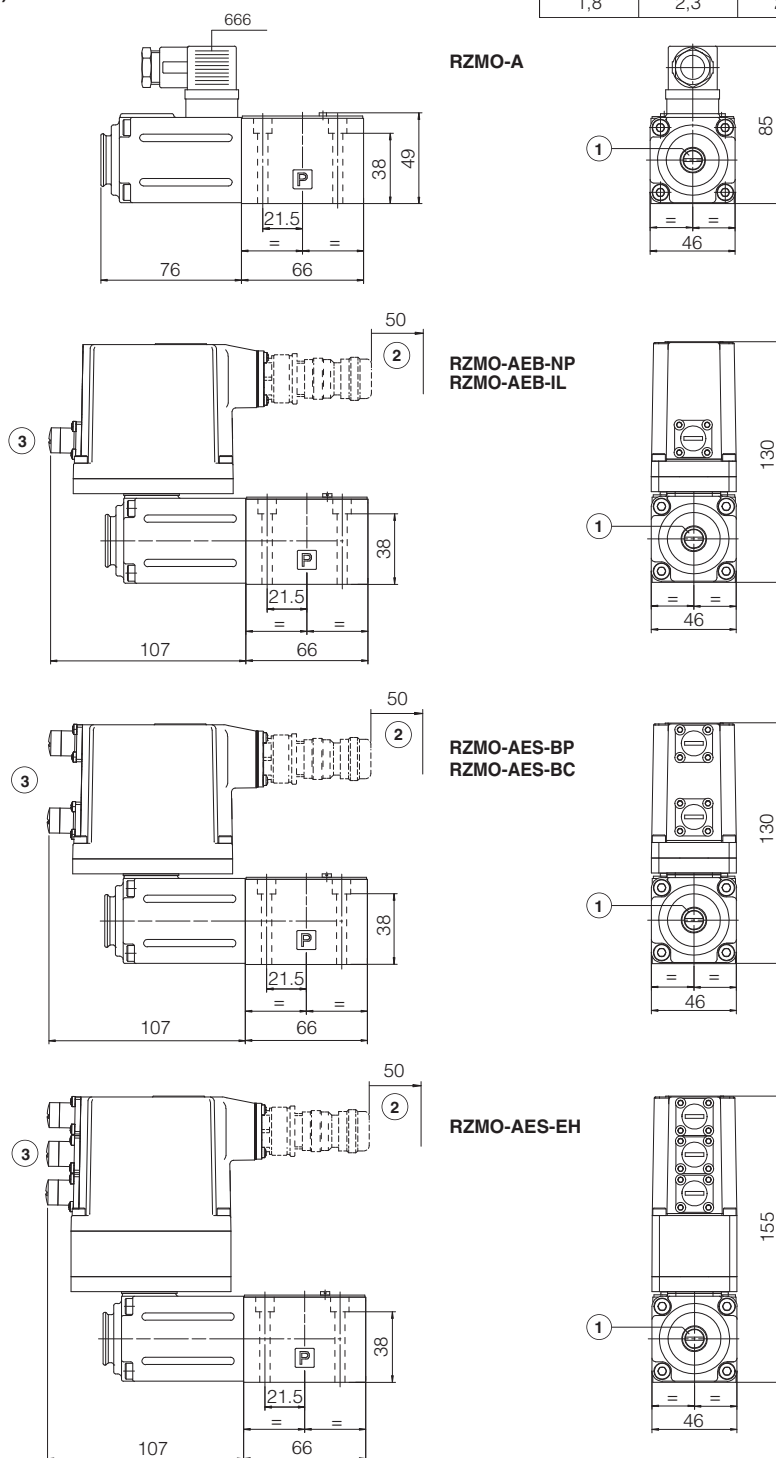

- ① = Air bleeding, see section 16  ② = Space required for connection cable and for connector removal  
③ = The dimensions of all connectors must be considered, see section 19.6, 19.7 and 19.8

23 RELATED DOCUMENTATION

<b>FS001</b>	Basics for digital electrohydraulics	<b>K800</b>	Electric and electronic connectors
<b>FS900</b>	Operating and maintenance information for proportional valves	<b>P005</b>	Mounting surfaces for electrohydraulic valves
<b>G010</b>	E-MI-AC analog driver	<b>QB200</b>	Quickstart for AEB valves commissioning
<b>G020</b>	E-MI-AS-IR digital driver	<b>QF200</b>	Quickstart for AES valves commissioning
<b>G030</b>	E-BM-AS digital driver	<b>E-MAN-MI-AS</b>	E-MI-AS-IR user manual (off-board)
<b>GS050</b>	E-BM-AES digital driver	<b>E-MAN-BM-AS</b>	E-BM-AS user manual (off-board)
<b>GS500</b>	Programming tools	<b>E-MAN-BM-AES</b>	E-BM-AES user manual (off-board)
<b>GS510</b>	Fieldbus	<b>E-MAN-RI-AEB</b>	AEB user manual
<b>GS520</b>	IO-Link interface	<b>E-MAN-RI-AES</b>	AES user manual