

# Proportional directional valves type **DHZO-AES** and **DKZOR-AES**

direct operated, without position transducer, ISO 4401 size 06 and 10

**AES execution included in this table is available only for running supplies or spare parts  
For new applications it is suggested new AEB and AES executions, see table FS160**

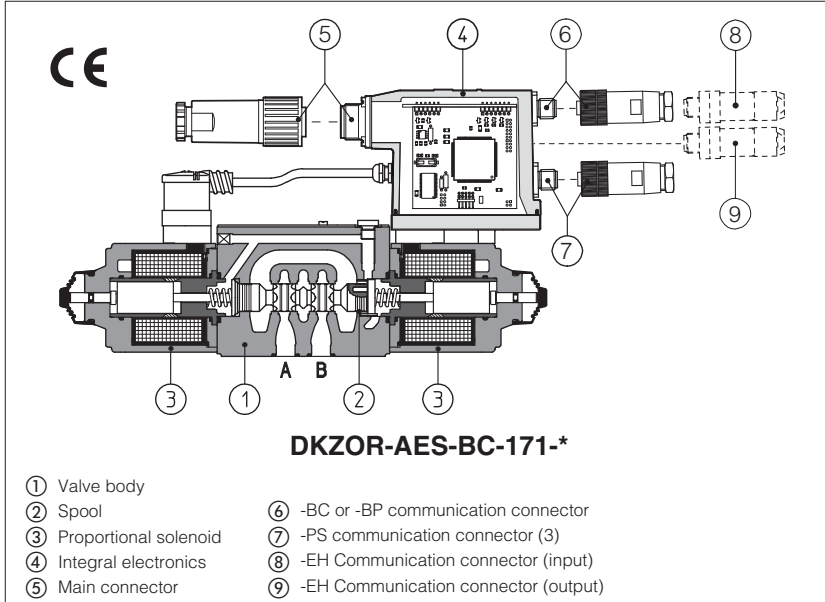

## 1 MODEL CODE

<b>DHZO</b> size 06	<b>DKZOR</b> size 10	<b>A</b> = without position transducer	<b>AE</b> = as A, plus integral electronics	<b>AES</b> = as A plus integral digital electronics	<b>PS</b> = Serial	<b>BC</b> = CANopen	<b>BP</b> = PROFIBUS DP	<b>EH</b> = EtherCAT	<b>Y</b> = external drain	<b>MO</b> = horizontal hand lever	<b>MV</b> = vertical hand lever	<b>BMO</b> = horizontal hand lever installed at side of port A	<b>BMV</b> = vertical hand lever installed at side of port A	<b>N</b> = manual micrometric adjustment	<b>NV</b> = as N plus handwheel and graduated scale	<b>I</b> = current reference input (4-20 mA)	<b>Q</b> = enable signal	<b>Z</b> = double power supply, enable fault and monitor (12 pin connector)	<b>W</b> = power limitation function (12 pin connector)				
Valve size - ISO 4401 <b>0</b> = size 06 <b>1</b> = size 10		Configuration, see section 3 <b>5</b> = external plus central position, spring centered <b>7</b> = 3 position, spring centered		Spool overlapping in central position, see sect. 3 <b>1</b> = P, A, B, T positive overlapping (20% of spool stroke) <b>3</b> = P positive overlapping; (20% of spool stroke) A, B, T, negative overlapping		Spool type (regulating characteristics) <b>L</b> = linear; <b>S</b> = progressive; <b>D</b> = differential-progressive (as <b>S</b> , but with P-A= Q, P-B= Q/2)		Spool size: <b>14, 1, 3, 5</b> = see section 3		Seals material, see section 4: - = NBR <b>PE</b> = FKM <b>BT</b> = HNBR (only -A)		Series number		Coil voltage (only for -A execution) see section 7: - = standard coil for 24V <sub>DC</sub> Atos drivers <b>6</b> = optional coil for 12V <sub>DC</sub> Atos drivers <b>18</b> = optional coil for low current drivers		Hydraulic options, see section 6: <b>B</b> = solenoid and integral electronics at side of port A <b>Y</b> = external drain		Options for -A execution see sect. 7: <b>MO</b> = horizontal hand lever <b>MV</b> = vertical hand lever <b>BMO</b> = horizontal hand lever installed at side of port A <b>BMV</b> = vertical hand lever installed at side of port A <b>N</b> = manual micrometric adjustment <b>NV</b> = as N plus handwheel and graduated scale		Electronics options for -AE execution see section 9: <b>I</b> = current reference input (4-20 mA) <b>Q</b> = enable signal		Electronics options for -AES execution see section 11: <b>Q</b> = enable signal <b>Z</b> = double power supply, enable fault and monitor (12 pin connector) <b>W</b> = power limitation function (12 pin connector) see section 11.3	

**Note:** (1) Serial communication interface always present, also for -BC, -BP and -EH options

## 2 ELECTRONIC DRIVERS FOR DHZO-A\*

Valve model	-A					-AE	-AES	
Drivers model	E-MI-AC-0°F	E-MI-AS-IR	E-BM-AC-0°F	E-BM-AS-PS	E-ME-AC-0°F	E-RP-AC-0°F	E-RI-AE	E-RI-AES
Data sheet	G010	G020	G025	G030	G035	G100	G110	G115

**Note:** For power supply and communication connector see section 14

DHZO-A\* and DKZOR-A\* are proportional valves, direct operated without position transducer, which provide both directional and non-compensated flow control according to the electronic reference signal.

They operate in association with electronic drivers, see section 2, which supply the proportional valves with proper current to align valve regulation to the reference signal supplied to the electronic driver.

- They are available in different executions:
- -A, without position transducer;
  - -AE, -AES as -A plus analogue (AE) or digital (AES) integral electronics ④;

The 4-way spool ②, sliding into a 5-chambers body ①, is directly operated by proportional solenoids ③.

The integral electronics ④ ensures factory presetting, fine functionality plus valve-to-valve interchangeability and simplified wiring and installation.

The electronic main connector ⑥ is fully interchangeable for -AE and -AES executions.

Standard 7 pin main connector is used for power supply, analog input reference and monitor signals.

12 pin connector is used for options /Z and /W (AES).

Following communication interfaces ⑥, ⑦ are available for the digital -AES execution:

- -PS, Serial communication interface for configuration, monitoring and firmware updating through Atos PC software - always present also for -BC, -BP and -EH options.
- -BC, CANopen interface
- -BP, PROFIBUS DP interface
- -EH, EtherCAT interface

The valves with -BC, -BP and -EH interfaces can be integrated into a fieldbus communication network and thus digitally operated by the machine control unit.

The coils are fully plastic encapsulated with insulation class H.

Mounting surface: **ISO 4401 sizes 06 and 10**

Max flow respectively up to **50 l/min** and **105 l/min** with valve differential pressure  $\Delta p = 30$  bar, see table 3.

Max pressure = **350 bar** for DHZO;  
**315 bar** for DKZOR.

### 3 HYDRAULIC CHARACTERISTICS (based on mineral oil ISO VG 46 at 50 °C)

Hydraulic symbols	*71, *71/B	*73, *73/B	*51	*53	*51/B	*53/B		
Valve model	DHZO				DKZOR			
Spool overlapping	1, 3	1, 3	1, 3	1, 3	1, 3	1, 3		
Spool type and size	L14	L1	S2	S3, L3, D3	S5, L5, D5	S3, L3, D3 S5, L5, D5		
Pressure limits [bar]	ports P, A, B = 350; T = 210 (250 with external drain /Y)					ports P, A, B = 315; T = 210 (250 /Y)		
Max flow (1) [l/min]	at $\Delta p = 10$ bar (P-T) at $\Delta p = 30$ bar (P-T) at $\Delta p = 70$ bar (P-T)	1 2 3	4,5 8 12	8 14 21	17 30 45	28 50 74	45 80 120	60 105 160
Response time (2) [ms]	< 30					< 40		
Hysteresis [%]	$\leq 5\%$					$\leq 5\%$		
Repeatability	$\pm 1\%$					$\pm 1\%$		

#### Notes:

- Above performance data refer to valves coupled with Atos electronic drivers, see section 2.
  - The flow regulated by the directional proportional valves is not pressure compensated, thus it is affected by the load variations. To keep constant the regulated flow under different load conditions, modular pressure compensators are available (see tab. D150).
- (1) For different  $\Delta p$ , the max flow is in accordance to the diagrams in sections 14.2 and 15.2  
(2) 0-100% step signal

### 4 MAIN CHARACTERISTICS

Assembly position	Any position					
Subplate surface finishing	Roughness index, Ra 0,4 flatness ratio 0,01/100 (ISO 1101)					
MTTFd valves according to EN ISO 13849	150 years, for further details, see technical table P004					
Ambient temperature	-A execution = -20°C ÷ +70°C (storage -20°C ÷ +80°C) /BT option -40°C ÷ +60°C (storage -20°C ÷ +70°C) -AE execution = -20°C ÷ +60°C (storage -20°C ÷ +70°C) -AES execution = -20°C ÷ +60°C (storage -20°C ÷ +70°C)					
Fluid	Hydraulic mineral oil HL, HLP as per DIN 51524					
Recommended viscosity	20 ÷ 100 mm <sup>2</sup> /s - max allowed range 15 ÷ 380 mm <sup>2</sup> /s					
Fluid contamination class	ISO 4406 class 20/18/15 NAS 1638 class 9, in line filters of 10 $\mu$ m ( $\beta_{10} \geq 75$ recommended)					
Fluid temperature	-20°C +60°C (standard seals)		-20°C +80°C (/PE option)		-40°C +60°C (/BT option)	
Coil code	DHZO-A*			DKZOR-A*		
	standard	option /6	option /18	standard	option /6	option /18
Coil resistance R at 20°C	3 ÷ 3,3 $\Omega$	2 ÷ 2,2 $\Omega$	13 ÷ 13,4 $\Omega$	3,8 ÷ 4,1 $\Omega$	2,2 ÷ 2,4 $\Omega$	12 ÷ 12,5 $\Omega$
Max. solenoid current	2,2 A	2,75 A	1 A	2,6 A	3,25 A	1,2 A
Max. power	30 Watt for DHZO-A execution; 35 Watt for DKZOR-A execution; 50 Watt for -AE and -AES executions					
Protection degree (CEI EN-60529)	IP65 for -A execution; IP67 for -AE and -AES, executions					
Duty factor	Continuous rating (ED=100%)					

### 5 GENERAL NOTES

DHZO and DKZOR proportional valves are CE marked according to the applicable Directives (e.g. Immunity/Emission EMC Directive and Low Voltage Directive). Installation, wirings and start-up procedures must be performed according to the general prescriptions shown in table F003 and in the installation notes supplied with relevant components.  
The electrical signals of the valve (e.g. monitor signals) must not be directly used to activate safety functions, like to switch-ON/OFF the machine's safety components, as prescribed by the European standards (Safety requirements of fluid technology systems and components-hydraulics, EN-982).

### 6 HYDRAULIC OPTIONS

- 6.1 Option /B** Solenoid (for valve configuration \*5\*), and integral electronics at side of port A. For hydraulic configuration vs. reference signal, see section 14.1 and 15.1  
**6.2 Option /Y** External drain advisable when the valve is used in double flow path, see section 14.5 and 15.5. Option /Y is mandatory if the pressure in port T exceeds 160 bar.

### 7 OPTIONS FOR -A EXECUTION

- 7.1 Option /6** optional coil to be used with Atos drivers with power supply 12 Vdc  
**7.2 Option /18** optional coil to be used with electronic drivers not supplied by Atos  
**7.3 Auxiliary hand lever**  
this option is available only for DHZO-A with spool type S3, S5, D3, D5, L3, L5. It allows to operate the valve in absence of electrical power supply. For detailed description of DHZO-A with hand lever option see table E138
- **Option /MO** horizontal hand lever
  - **Option /MV** vertical hand lever
  - **Option /BMO** horizontal hand lever installed at side of port A
  - **Option /BMV** vertical hand lever installed at side of port A

The following supplementary options allow to operate the valve in absence of electrical power supply by means of a micrometric screw replacing the standard solenoid manual override, see table TK500

- 7.4 Option /N** manual micrometric adjustment  
**7.5 Option /NV** as /N plus handwheel and graduated scale

### 8 CONNECTIONS FOR -A EXECUTION

SOLENOID POWER SUPPLY CONNECTOR	
PIN	Signal description
1	SUPPLY
2	SUPPLY
3	GND

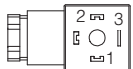

## 9 ANALOG INTEGRAL DRIVERS -AE - OPTIONS

Standard driver execution provides on the 7 pin main connector:

- Power supply** - 24Vdc must be appropriately stabilized or rectified and filtered; a 2,5 A safety fuse is required in series to the driver power supply. Apply at least a 10000  $\mu$ F/40 V capacitance to single phase rectifiers or a 4700  $\mu$ F/40 V capacitance to three phase rectifiers
- Reference input signal** - analog differential input with  $\pm 10$  Vdc nominal range (pin D, E), proportional to desired coil current
- Monitor output signal** - analog output signal proportional to the actual valve's coil current (1V monitor = 1A coil current)

Following options are available to adapt standard execution to special application requirements:

### 9.1 Option /I

It provides the 4÷20 mA current reference signal instead of the standard  $\pm 10$  Vdc. Monitor output signal is still the standard  $\pm 10$  Vdc. It is normally used in case of long distance between the machine control unit and the valve or where the reference signal can be affected by electrical noise; the valve functioning is disabled in case of reference signal cable breakage.

### 9.2 Option /Q

It provides the possibility to enable or disable the valve functioning without cutting the power supply (the valve functioning is disabled but the driver current output stage is still active). To enable the driver supply a 24Vdc on the enable input signal.

### 9.2 Possible combined option: /IQ

## 10 ANALOG INTEGRAL DRIVERS -AE - MAIN FUNCTIONS AND ELECTRONIC CONNECTIONS

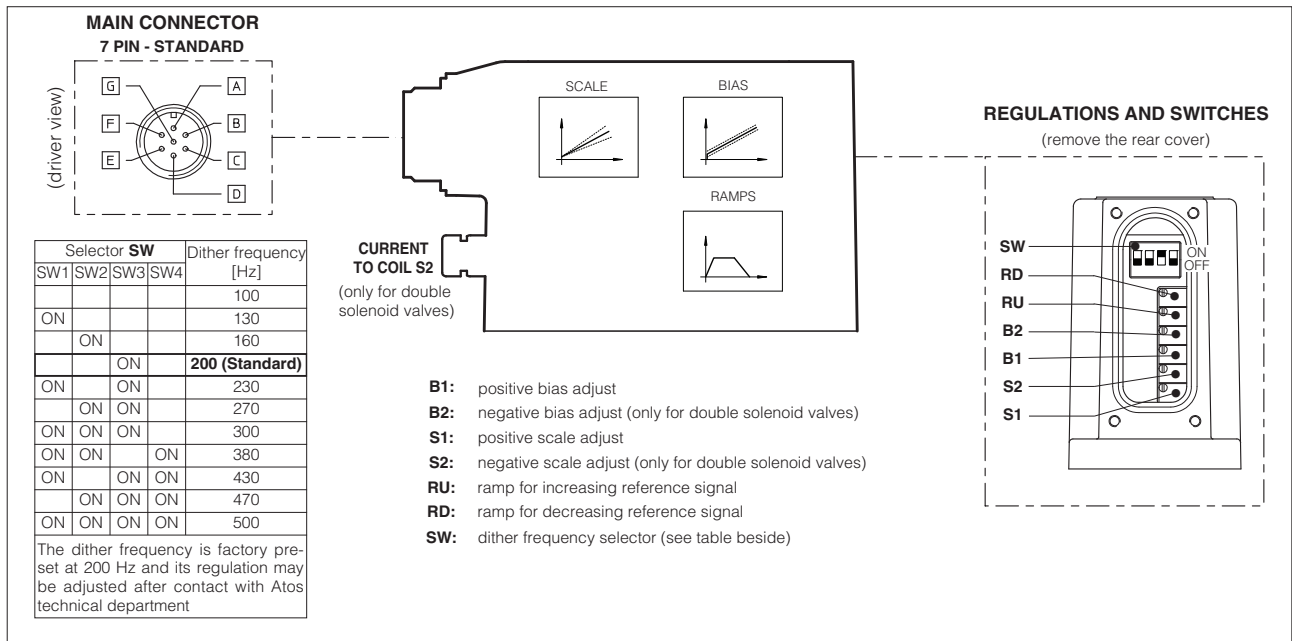

### 10.1 7 PIN MAIN CONNECTOR

PIN	SIGNAL	TECHNICAL SPECIFICATIONS	NOTES
A	V+	Power supply 24 Vdc for solenoid power stage and driver logic	Input - power supply
B	V0	Power supply 0 Vdc for solenoid power stage and driver logic	Gnd - power supply
C (1)	AGND	Ground - signal zero for MONITOR signal	Gnd - analog signal
	ENABLE	Enable (24 Vdc) or disable (0 Vdc) the driver (for /Q option)	Input - on/off signal
D	INPUT+	Reference analog differential input: $\pm 10$ Vdc maximum range (4 ÷ 20 mA for /I option) Default setting for single solenoid valves: 0÷+10 Vdc	Input - analog signal
E	INPUT -	Default setting for double solenoid valves: $\pm 10$ Vdc	
F	MONITOR	Monitor analog output: $\pm 5$ Vdc maximum range; 1 V = 1 A	Output - analog signal
G	EARTH	Internally connected to the driver housing	

**Note:** (1) with /Q option ENABLE signal replaces AGND on pin C; MONITOR signal is referred to pin B.

A minimum time of 60ms to 160ms have to be considered between the driver energizing with the 24 Vdc power supply and when the valve is ready to operate. During this time the current to the valve coils is switched to zero

## 11 DIGITAL INTEGRAL DRIVERS -AES - OPTIONS

Standard driver execution provides on the 7 pin main connector:

- Power supply** - 24Vdc must be appropriately stabilized or rectified and filtered; a 2,5 A safety fuse is required in series to each driver power supply. Apply at least a 10000 µF/40 V capacitance to single phase rectifiers or a 4700 µF/40 V capacitance to three phase rectifiers.
- Reference input signal** - analog differential input with ±10Vdc nominal range (pin D,E), proportional to desired coil current (4÷20 mA with cable break detection, ±10 mA, ±20 mA or 0÷20 mA software selectable)
- Monitor output signal** - analog output signal proportional to the actual valve's coil current (1V monitor = 1A coil current)

Following options are available to adapt standard execution to special application requirements:

### 11.1 Option /Q

To enable the driver, supply 24Vdc on pin C referred to pin B: when the enable signal is set to zero the valve status is software selectable, by factory default the valve functioning is disabled (zero current to the solenoid) but the driver current output stage is still active. For the complete list of selectable status, see tab. G115.

### 11.2 Option /Z

It provides, on the 12 pin main connector, the following additional features:

#### Logic power supply

Separated power supply for the solenoid (pin 1, 2) and for the digital electronic circuits (pin 9, 10).

Cutting solenoid power supply allows to interrupt the valve functioning but keeping energized the digital electronics thus avoiding fault conditions of the machine fieldbus controller. This condition allows to realize safety systems in compliance with European Norms EN13849-1 (ex EN954-1).

#### Enable Input Signal

To enable the driver, supply 24Vdc on pin 3 referred to pin 2: when the enable signal is set to zero the valve status is software selectable, by factory default the valve functioning is disabled (zero current to the solenoid) but the driver current output stage is still active. For the complete list of selectable status, see tab. G115.

#### Fault Output Signal

Fault output signal indicates fault conditions of the driver (solenoid short circuits/not connected, reference signal cable broken for 4÷20mA input, etc.). Fault presence corresponds to 0 Vdc, normal working corresponds to 24Vdc (pin 11 referred to pin 2): Fault status is not affected by the Enable input signal

### 11.3 Option /W - only for valves coupled with pressure compensator type HC-011 or KC-011 (see tab. D150).

It provides, on the 12 pin main connector, the above option /Z features plus the hydraulic power limitation function.

The driver receives the flow reference signal by the analog external input INPUT+ and a pressure transducer remotely installed in the hydraulic system, has to be connected to the driver's analog input TR.

When the actual requested hydraulic power  $p \times Q$  ( $TR \times INPUT+$ ) reaches the max power limit ( $p1 \times Q1$ ), internally set by software, the driver automatically reduces the flow regulation of the valve. The higher is the pressure feedback the lower is the valve's regulated flow:

$$\text{Flow regulation} = \text{Min} \left( \frac{\text{PowerLimit [sw setting]}}{\text{Transducer Pressure [TR]}} ; \text{Flow Reference [INPUT+]} \right)$$

For detailed information on hydraulic power limitation, see tab. G115

## 12 DIGITAL INTEGRAL DRIVERS -AES - MAIN FUNCTIONS AND ELECTRONIC CONNECTIONS

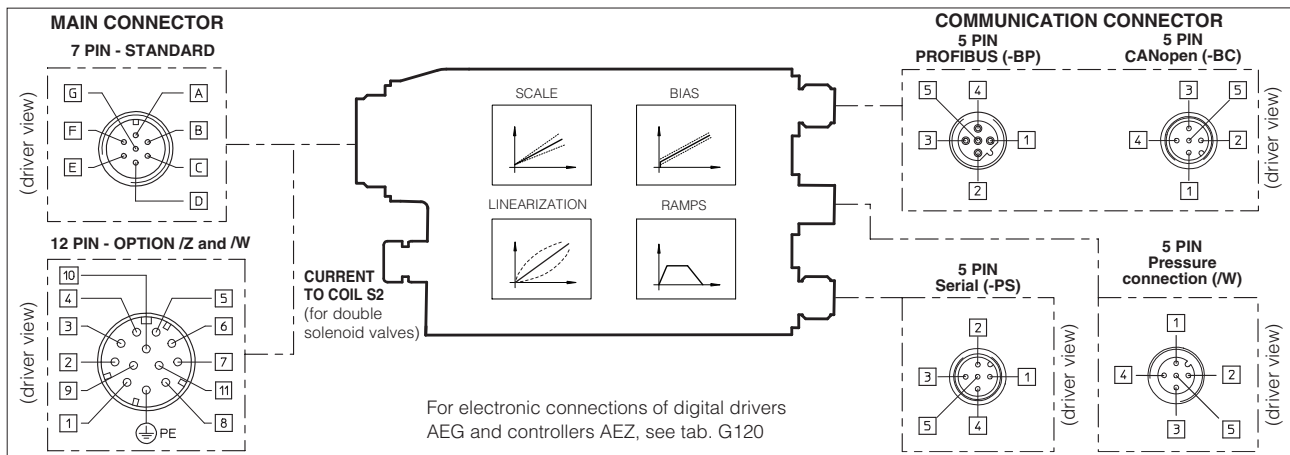

### 12.1 7 or 12 PIN MAIN CONNECTOR (-AES standard, /Q, /Z, /W options)

Standard 7pin	/Z, /W options 12pin	SIGNAL	TECHNICAL SPECIFICATIONS	NOTES
A	1	V+	Power supply 24 Vdc for solenoid power stage (and for driver logic on 7 pin connection)	Input - power supply
B	2	V0	Power supply 0 Vdc for solenoid power stage (and for driver logic on 7 pin connection)	Gnd - power supply
C (option /Q)	3	ENABLE	Enable (24 Vdc) or disable (0 Vdc) the driver	Input - on/off signal
D	4	INPUT+	Reference analog input: ±10 Vdc / ±20 mA maximum range software selectable Default setting for single solenoid valves: 0÷+10 Vdc, differential input	Input - analog signal
E	-	INPUT -	Default setting for double solenoid valves: ±10 Vdc, differential input /Z and /W options: common mode INPUT+ referred to AGND	
C	5	AGND	Ground - signal zero for MONITOR signal (INPUT+ signal only for /Z and /W options)	Gnd - analog signal
F	6	MONITOR	Monitor analog output: ±5 Vdc maximum range; Default setting 1V = 1A	Output - analog signal
-	7	NC	do not connect	
-	8	MONITOR 2	2nd monitor analog output: ±5 Vdc maximum range ( <b>only for /W option</b> )	Output - analog signal
-	9	VL+	Power supply 24 Vdc for driver logic	Input - power supply
-	10	VLO	Power supply 0 Vdc for driver logic	Gnd - power supply
-	11	FAULT	Fault (0 Vdc) or normal working (24 Vdc)	Output - on/off signal
G	PE	EARTH	Internally connected to the driver housing	

**Note:** A minimum time of 270 to 340 ms have be considered between the driver energizing with the 24 VDC power supply and when the valve is ready to operate. During this time the current to the valve coils is switched to zero.

## 12.2 ELECTRONIC CONNECTIONS - 5 PIN COMMUNICATION AND PRESSURE TRANSDUCER CONNECTORS

PIN	Serial (-PS)		CANopen (-BC)		PROFIBUS DP (-BP)	
	SIGNAL	TECHNICAL SPECIFICATION	SIGNAL	TECHNICAL SPECIFICATION	SIGNAL	TECHNICAL SPECIFICATION
1	NC	do not connect	CAN_SHLD	Shield	+5V	for termination
2	NC	do not connect	NC	do not connect	LINE-A	Bus line (high)
3	RS_GND	Signal zero data line	CAN_GND	Signal zero data line	DGND	data line and termination Signal zero
4	RS_RX	Valves receiving data line	CAN_H	Bus line (high)	LINE-B	Bus line (low)
5	RS_TX	Valves transmitting data line	CAN_L	Bus line (low)	SHIELD	do not connect

### 12.3 5 PIN M12 PRESSURE CONNECTOR (only for /W option)

PIN	Input Voltage (Software selectable)		Input Current (Software selectable)	
	SIGNAL	TECHNICAL SPECIFICATION	SIGNAL	TECHNICAL SPECIFICATION
1	VT	Remote transducer power supply 24 Vdc	VT	Remote transducer power supply 24 Vdc
2	TR	Remote transducer signal (0 ÷ 10 Vdc)	TR	Remote transducer signal (0 ÷ 20 mA)
3	AGND	signal zero for power supply and signal	NC	do not connect
4	NC	do not connect	NC	do not connect
5	NC	do not connect	NC	do not connect

## 13 DIGITAL INTEGRAL DRIVER -AES-EH - MAIN FUNCTIONS AND ELECTRONIC CONNECTIONS

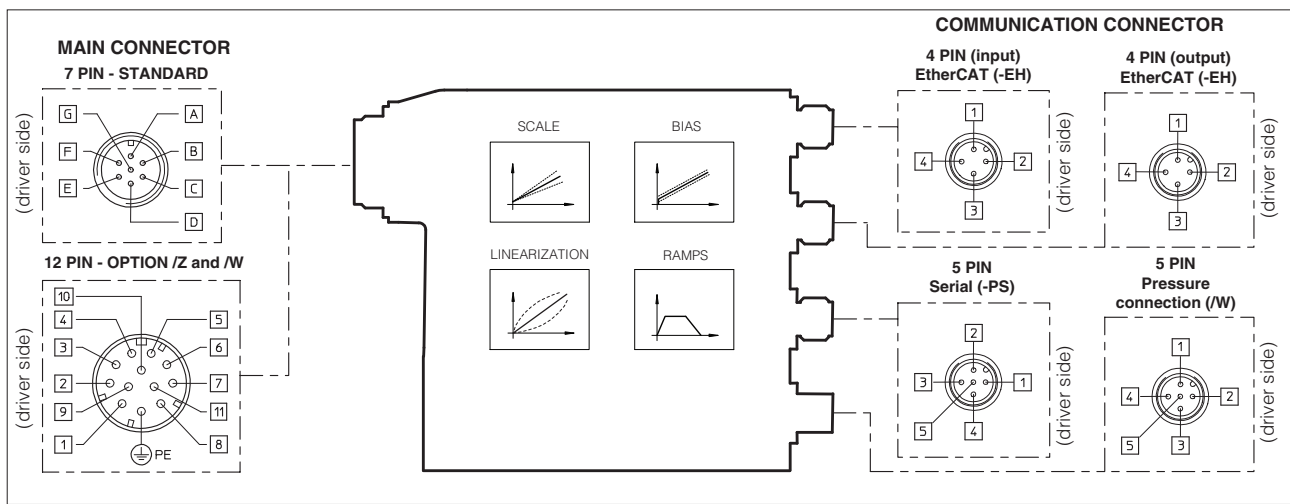

**Note:** for the electronic connections of 7 or 12 pin main connector, see section 12.1  
for pressure transducer electronic connector (option /W) see section 12.3)

### 13.1 4 & 5 PIN M12 COMMUNICATION CONNECTORS

Serial (-PS)			EtherCAT (-EH)		
PIN	SIGNAL	TECHNICAL SPECIFICATION	PIN	SIGNAL	TECHNICAL SPECIFICATION
1	NC	do not connect	1	TX+	Transmitter
2	NC	do not connect	2	RX+	Receiver
3	RS_GND	Signal zero data line	3	TX-	Transmitter
4	RS_RX	Valves receiving data line	4	RX-	Receiver
5	RS_TX	Valves transmitting data line	Housing	Shield	Positioned on control cabinet side

## 14 MODEL CODES OF POWER SUPPLY AND COMMUNICATION CONNECTORS (to be ordered separately)

VALVE VERSION	-A	-AE, -AES		-AES/Z	-AES/W -AEZ	-Serial (-PS) or CANopen (-BC)	PROFIBUS DP (-BP)	EtherCAT (-EH)
CONNECTOR CODE	666	ZH-7P	ZM-7P	ZH-12P	ZH-5PM	ZH-5P	ZH-5P/BP	ZM-4PM/EH
PROTECTION DEGREE	IP65	IP67	IP67	IP67	IP67	IP67	IP67	IP67
DATA SHEET	K500	G110, G115, K500			G115, K500	G115, K500		

connectors supplied with the valve

## 15 SOFTWARE TOOLS

The driver configuration and parameters can be easily set with the Atos E-SW programming software, available in four different versions according to the driver's communication execution: E-SW-PS (Serial), E-SW-BC (CANopen), E-SW-BP (PROFIBUS DP), E-SW-EH (EtherCAT). Programming software E-SW-BC, E-SW-BP, E-SW-EH for BC, BP and -EH drivers, can be also used to modify the valve's parameterization through the serial communication interface, without disconnecting the valve from the machine's bus line.

For a more detailed description of software interface, PC requirements, adapters, cables and terminators, please refer to technical table G500.

**Programming software, must be ordered separately:**

**E-SW-\*** (mandatory - first supply) = Dvd including E-SW-<sup>\*</sup> software installer and operator manuals; it allows the registration to Atos digital service

**E-SW-<sup>\*</sup>-N** (optional - next supplies) = as above but not allowing the registration to Atos digital service

On first supply of the E-SW-<sup>\*</sup> software, it is required to apply for the registration in the Atos download area: [www.download atos.com](http://www.download atos.com).

Once the registration is completed, the password will be sent by email.

The software remains active for 10 days from the installation date and then it stops until the user inputs his password.

With the password you can also download, in your personal area, the latest releases of the Atos software, manuals, drivers and configuration files.

**16 DIAGRAMS FOR DHZO** (based on mineral oil ISO VG 46 at 50 °C)

**5.1 Regulation diagrams**

- 1 = linear spool L14
- 2 = linear spool L1
- 3 = progressive spool S2
- 4 = linear spool L3
- 5 = progressive spool S3, D3
- 6 = linear spool L5
- 7 = progressive spool S5, D5

**Note:** hydraulic configuration vs reference signal for double solenoid valves (standard and option /B)

- Reference signal  $0 \div +10\text{ V}$  } P → A / B → T
- $12 \div 20\text{ mA}$  }
- Reference signal  $0 \div -10\text{ V}$  } P → B / A → T
- $4 \div 12\text{ mA}$  }

Hydraulic configuration vs reference signal for single solenoid valves:

- Reference signal:
- $0 \div +10\text{ V}$  } P → A / B → T (standard)
- $4 \div 20\text{ mA}$  } P → B / A → T (option /B)

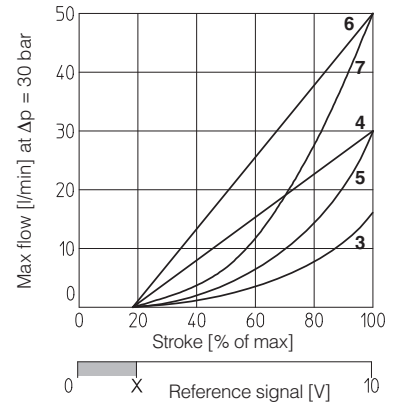
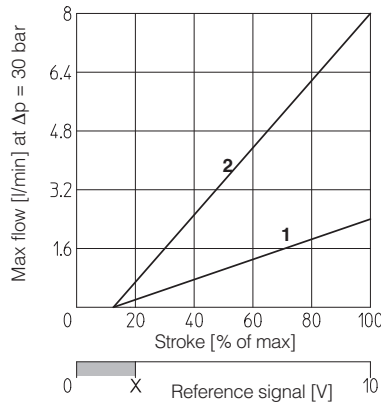

**X** = Threshold for bias activation depending to the valve type and amplifier type

**16.2 Flow /Δp diagrams**

stated at 100% of valve stroke

- 1 = spool L14
- 2 = spool L1
- 3 = spool S2
- 4 = spool S3, L3, D3
- 5 = spool S5, L5, D5

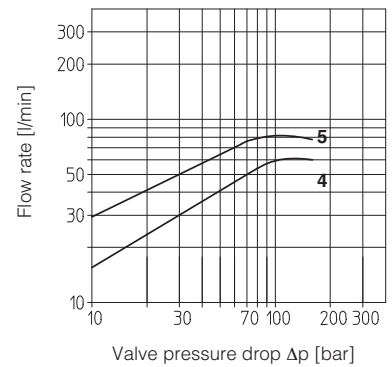
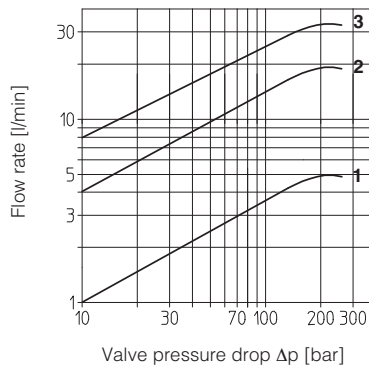

**16.3 Operating limits**

- 1 = spool L14
- 2 = spool L1
- 3 = spool S2
- 4 = spool L3, S3, D3
- 5 = spool L5, S5, D5

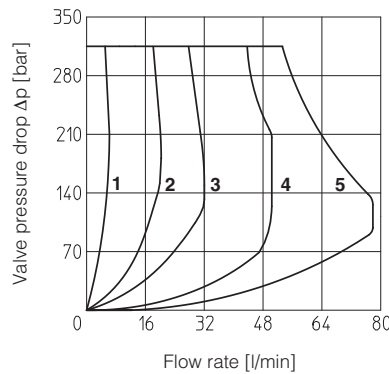

**16.4 Operation as throttle valve**

Single solenoid valves (DHZO-\*-051) can be used as simple throttle valves:  
Pmax = 250 bar (option /Y advisable)

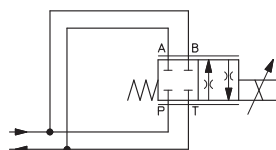

	SPOOL TYPE						
	L14	L1	S2	L3	S3	L5	S5
Max flow Δp= 70bar [l/min]	6	20	40	80	100		

**17 DIAGRAMS FOR DKZOR** (based on mineral oil ISO VG 46 at 50 °C)

**17.1 Regulation diagrams**

- 1 = linear spool L3
- 2 = progressive spool S3, D3
- 3 = linear spool L5
- 4 = progressive spool S5, D5

**Note:**

Hydraulic configuration vs reference signal for double solenoid valves (standard and option /B)

Reference signal  $0 \div +10 \text{ V}$  }  $P \rightarrow A / B \rightarrow T$   
 $12 \div 20 \text{ mA}$  }  
 Reference signal  $0 \div -10 \text{ V}$  }  $P \rightarrow B / A \rightarrow T$   
 $4 \div 12 \text{ mA}$  }

Hydraulic configuration vs reference signal for single solenoid valves:

Reference signal:  
 $0 \div +10 \text{ V}$  }  $P \rightarrow A / B \rightarrow T$  (standard)  
 $4 \div 20 \text{ mA}$  }  $P \rightarrow B / A \rightarrow T$  (option /B)

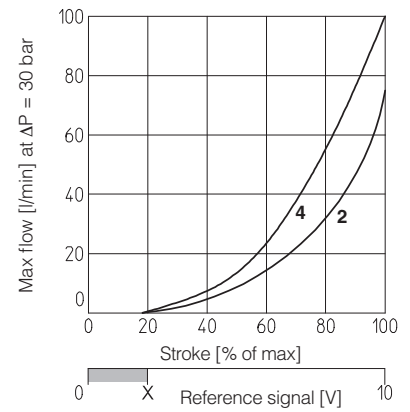
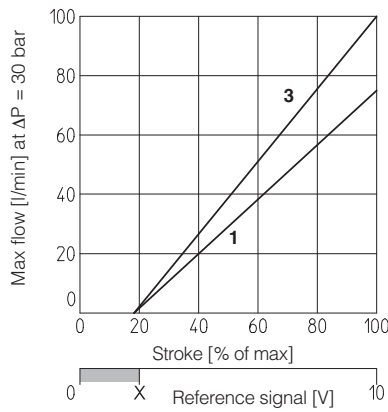

**X** = Threshold for bias activation depending to the valve type and amplifier type

**17.2 Flow /Δp diagrams**

stated at 100% of valve stroke

- 1 = spool S3, L3, D3
- 2 = spool S5, L5, D5

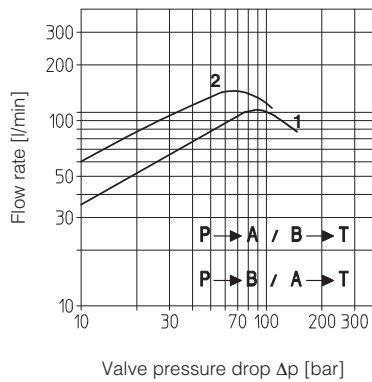

**17.3 Operating limits**

- 1 = spool L3, S3, D3
- 2 = spool L5, S5, D5

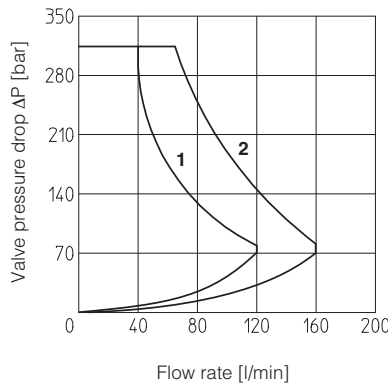

**17.4 Operation as throttle valve**

Single solenoid valves (DKZOR-\*-151) can be used as simple throttle valves:  
 Pmax = 250 bar (option /Y advisable)

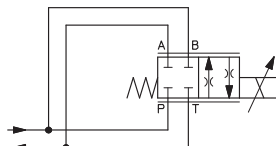

	SPOOL TYPE			
	L3	S3	L5	S5
Max flow Δp= 30 bar [l/min]	100		160	

18 INSTALLATION DIMENSIONS FOR DHZO [mm]

ISO 4401: 2005

Mounting surface: 4401-03-02-0-05 (see table P005)  
 (for /Y version, surface 4401-03-03-0-05 without X port)

Fastening bolts: 4 socket head screws M5x50 class 12.9

Tightening torque = 8 Nm

Seals: 4 OR 108; 1 OR 2025

Diameter of ports A, B, P, T:  $\varnothing$  7,5 mm (max)

Diameter of port Y:  $\varnothing$  = 3,2 mm (only for /Y option)

DHZO-A-05

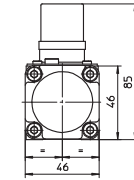
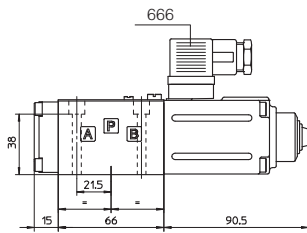

Mass: 1,9 kg

DHZO-A-07

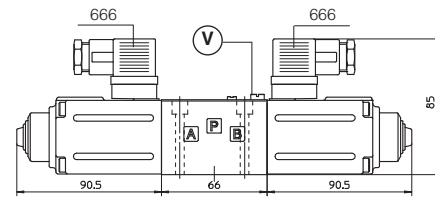

Mass: 2,6 kg

Note: for option /B the solenoid is at side of port A

DHZO-AE-05

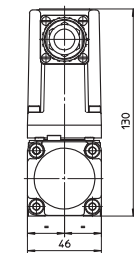
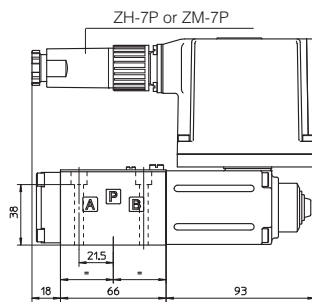

Mass: 2,3 kg

DHZO-AE-07

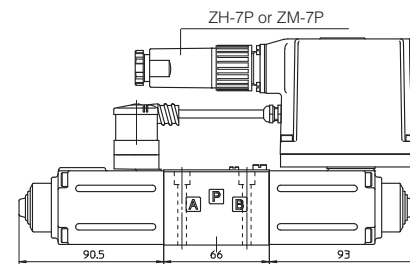

Mass: 3,1 kg

DHZO-AES-05

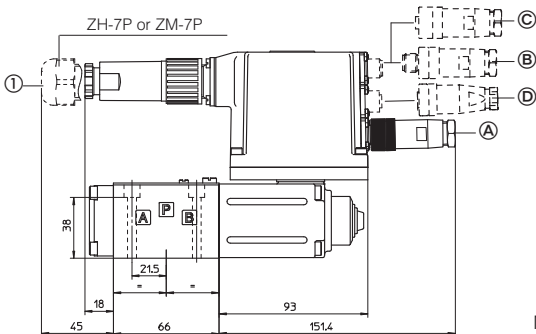

Mass: 2,3 kg

DHZO-AES-07

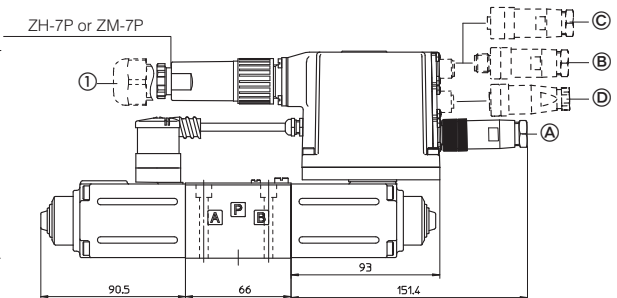

Mass: 3,1 kg

DHZO-AES-EH-05

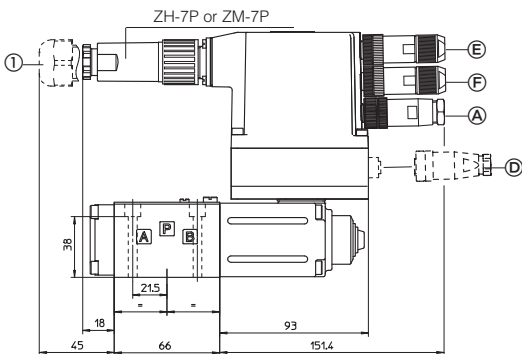

Mass: 2,4 kg

DHZO-AES-EH-07

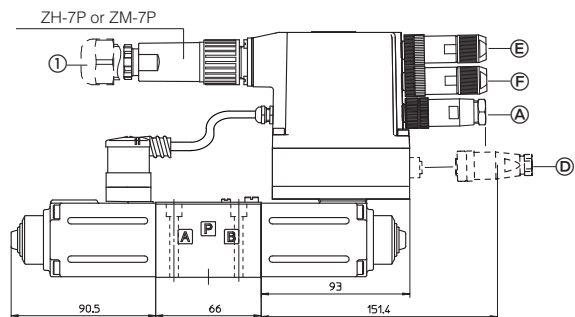

Mass: 3,2 kg

- Ⓐ -PS communication interface, ZH-5P connector
- Ⓑ -BP communication interface, ZH-5P/BP connector
- Ⓒ -BC communication interface, ZH-5P connector
- Ⓓ -Option /W pressure transducer interface, ZH-5PM connector
- Ⓔ -EH communication interface (input), ZM-4PM/EH connector
- Ⓕ -EH communication interface (output), ZM-4PM/EH connector

Ⓛ dotted line = 12 pin connector ZH-12P for option /Z, /W



19 INSTALLATION DIMENSIONS FOR DKZOR [mm]

ISO 4401: 2005

Mounting surface: 4401-05-04-0-05 (see table P005)  
 (for /Y version, surface 4401-05-05-0-05 without X port)

Fastening bolts: 4 socket head screws M6x40 class 12.9

Tightening torque = 15 Nm

Seals: 5 OR 2050; 1 OR 108

Diameter of ports A, B, P, T:  $\varnothing$  11,2 mm (max)

Diameter of port Y:  $\varnothing$  = 5 mm (only for /Y option)

DKZOR-A-15

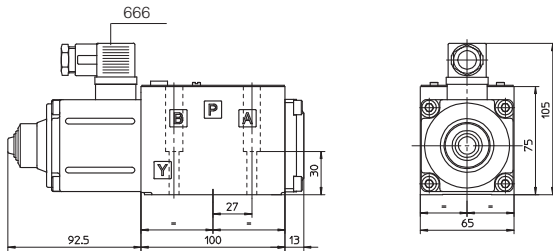

Mass: 3,8 kg

DKZOR-A-17

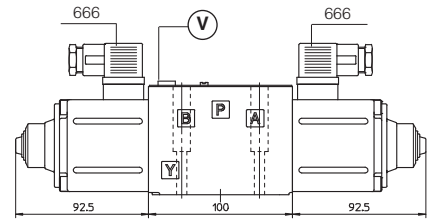

Mass: 4,5 kg

Note: for option /B the solenoid is at side of port A

DKZOR-AE-15

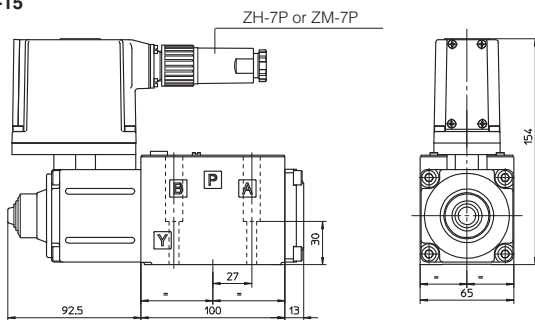

Mass: 4,3 kg

DKZOR-AE-17

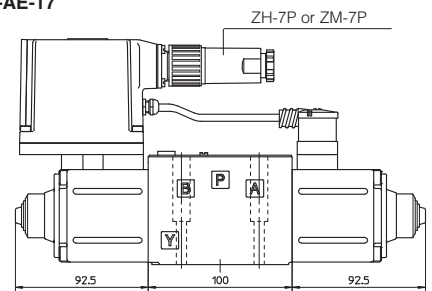

Mass: 5,0 kg

DKZOR-AES-15

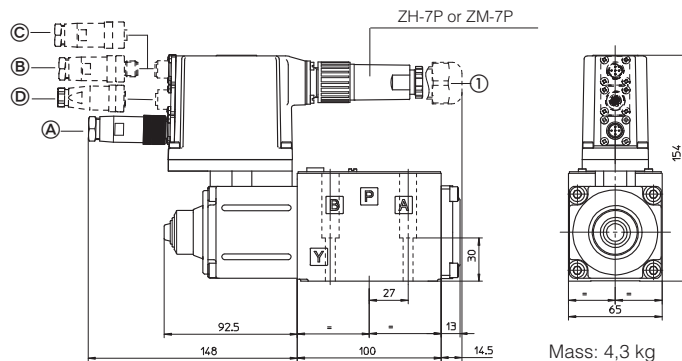

Mass: 4,3 kg

DKZOR-AES-17

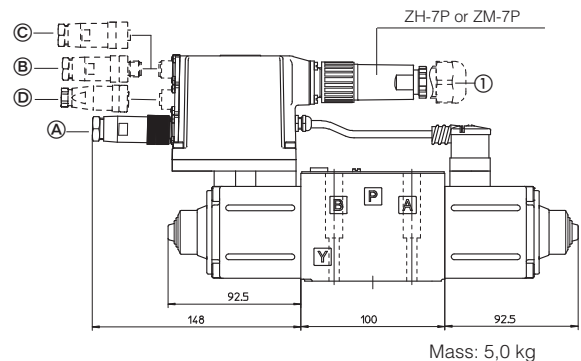

Mass: 5,0 kg

DKZOR-AES-EH-15

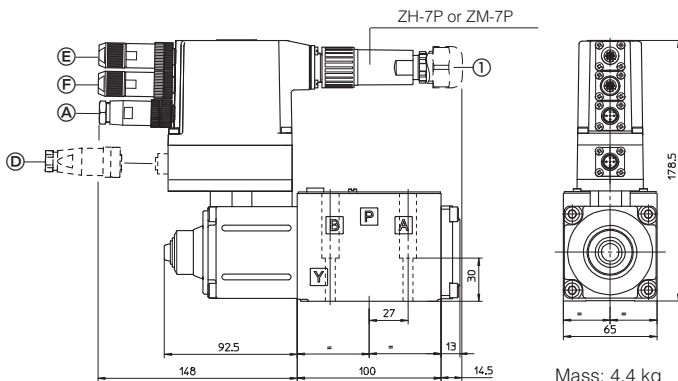

Mass: 4,4 kg

DKZOR-AES-EH-17

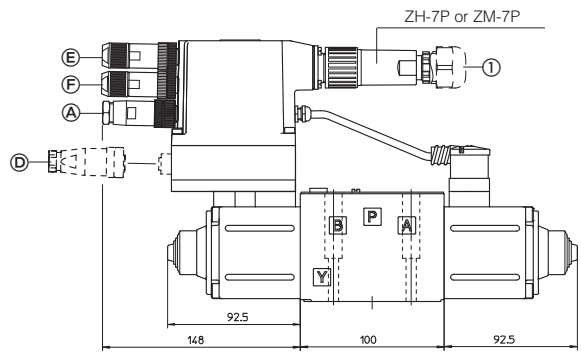

Mass: 5,1 kg

- Ⓐ -PS communication interface, ZH-5P connector
- Ⓑ -BP communication interface, ZH-5P/BP connector
- Ⓒ -BC communication interface, ZH-5P connector
- Ⓓ -Option /W pressure transducer interface, ZH-5PM connector
- Ⓔ -EH communication interface (input), ZM-4PM/EH connector
- Ⓕ -EH communication interface (output), ZM-4PM/EH connector

Ⓖ dotted line = 12 pin connector ZH-12P for option /Z, /W

