

Check valves type SADR

in-line mounting - from G 1/4" to G 1" threaded ports

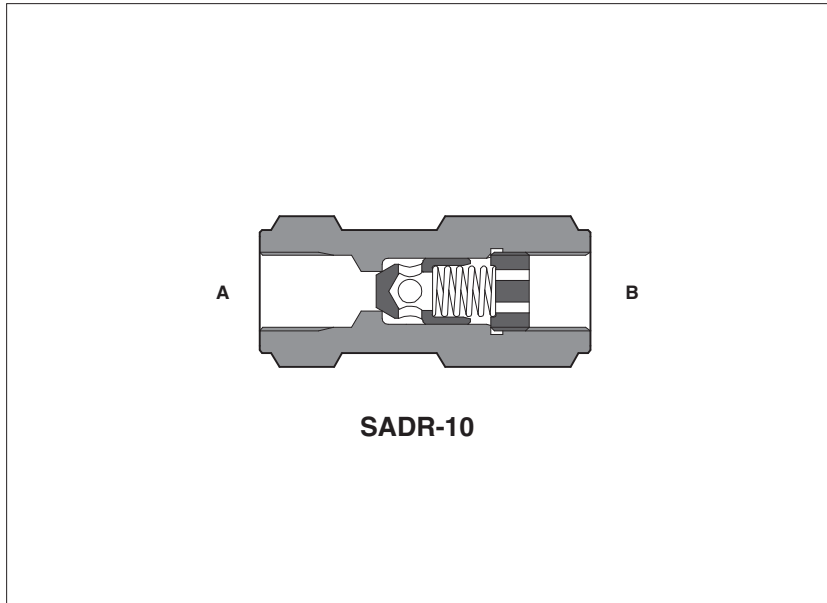

SADR are direct operated check valves for in-line mounting available with port size from 1/4" to 1" GAS.

They are designed to operate in hydraulic systems with hydraulic mineral oil or synthetic fluids having similar lubricating characteristics.

Flow up to **360 l/min**
Pressure up to **400 bar**

1 MODEL CODE

SADR	-	10	/	4	**
Check valve in-line mounting					Series number
Size/threaded connections:		Cracking pressure:			
06 = G 1/4"		- =0,5 bar			
10 = G 3/8"		/2 = 2 bar			
15 = G 1/2"		/4 = 4 bar			
20 = G 3/4"		/8 = 8 bar			
25 = G 1"					

2 HYDRAULIC CHARACTERISTICS

Hydraulic symbol					
Valve model	SADR-06	SADR-10	SADR-15	SADR-20	SADR-25
Max recommended flow [l/min]	40	80	150	300	360
Max pressure [bar]	400			350	

3 MAIN CHARACTERISTICS OF CHECK VALVES TYPE SADR

Assembly position / location	Any position
Fluid	Hydraulic oil as per DIN 51524 ... 535;
Recommended viscosity	15 ÷ 100 mm ² /s - max allowed range 2,8 ÷ 500 mm ² /s
Max fluid contamination level	ISO4406 class 20/18/15 NAS1638 class 9, see also filter section at www.atos.com or KTF catalog
Fluid temperature	-20 ÷ +80°C
Flow direction	As shown in the symbol at section 2
Rated flow	See diagrams Q/Δp at section 4

4 FLOW VERSUS PRESSURE DROP DIAGRAMS Based on based on mineral oil ISO VG 46 at 50°C

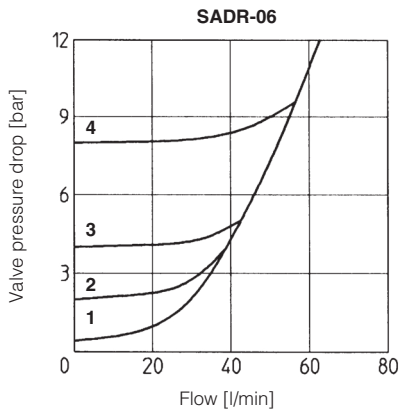

- 1 = SADR-06
- 2 = SADR-06/2
- 3 = SADR-06/4
- 4 = SADR-06/8

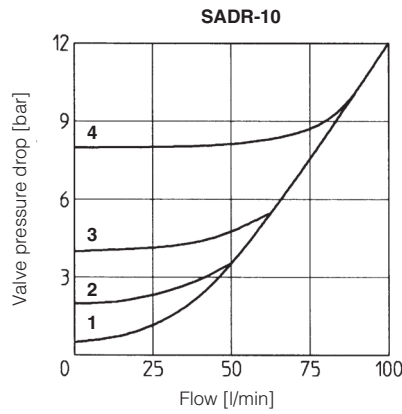

- 1 = SADR-10
- 2 = SADR-10/2
- 3 = SADR-10/4
- 4 = SADR-10/8

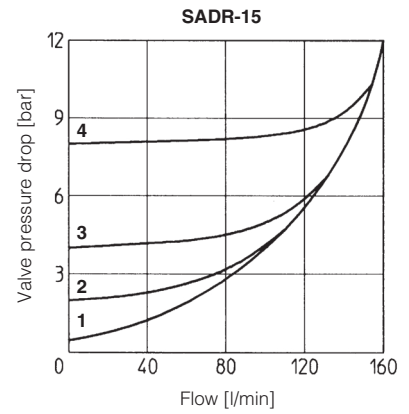

- 1 = SADR-15
- 2 = SADR-15/2
- 3 = SADR-15/4
- 4 = SADR-15/8

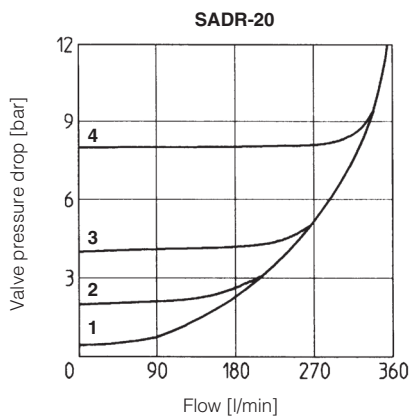

- 1 = SADR-20
- 2 = SADR-20/2
- 3 = SADR-20/4
- 4 = SADR-20/8

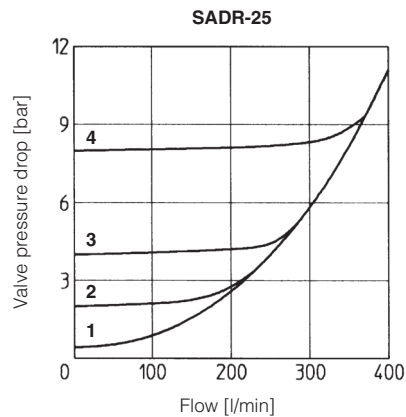

- 1 = SADR-25
- 2 = SADR-25/2
- 3 = SADR-25/4
- 4 = SADR-25/8

5 DIMENSIONS [mm]

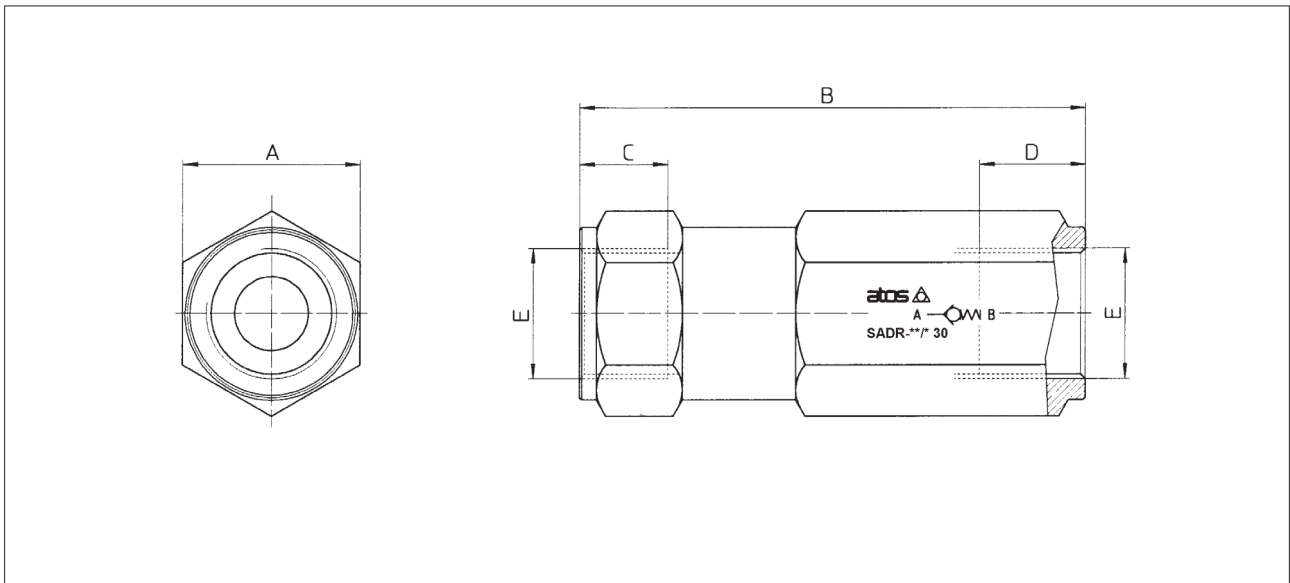

Model	A	B	C	D	E	Mass [kg]
SADR - 06	22	67	12	13	G 1/4"	0,2
SADR - 10	27	70	12	13	G 3/8"	0,4
SADR - 15	32	82,5	14	17	G 1/2"	0,6
SADR - 20	36	102,5	16	21,5	G 3/4"	0,9
SADR - 25	46	120	18	24,5	G 1"	2,1