

Proportional relief valves

piloted, without transducer

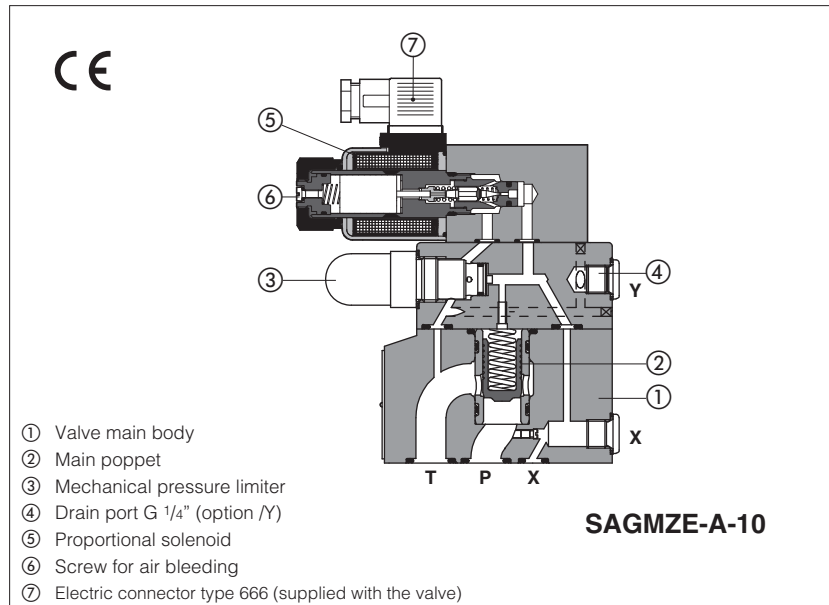

SAGMZE-A

Poppet type, pilot operated proportional relief valves for pressure open loop controls.

They operate in association with electronic drivers, see section 2, which supply the proportional valves with proper current to align the valve regulation to the reference signal.

The solenoid coils are available with different nominal resistances depending to the voltage supply to the electronic driver (12 Vdc or 24 Vdc) and to the driver characteristics, see section 2 and 3.

Mounting surface: **ISO 6264**

Size: **10, 20, 32**

Max flow: **200, 400, 600 l/min**

Max pressure: **350 bar**

1 MODEL CODE

SAGMZE	-	A	-	10	/	315	/	*	-	*	/	*	**	/	*
Proportional pressure relief valve pilot operated															
A = for off-board driver, see section 2															
Valve size ISO 6264 10, 20, 32															
Max regulated pressure: 50 = 50 bar 210 = 210 bar 350 = 350 bar 100 = 100 bar 315 = 315 bar															
Hydraulic options, see section 8 E = external pilot Y = external drain (only pipe connection G 1/4")															
Seals material, see section 4: - = NBR PE = FKM BT = HNBR															
Series number															
Coil voltage, see section 2 and 3: - = standard coil for 24Vdc Atos drivers 6 = optional coil for 12Vdc Atos drivers 18 = optional coil for low current drivers (1)															
Coils with special connectors, see section 12 - = omit for standard DIN connector J = AMP Junior Timer connector K = Deutsch connector S = Lead Wire connection															

(1) select valve's coil voltage /18 in case of electronic drivers not supplied by Atos, with power supply 24Vdc

2 OFF-BOARD ELECTRONIC DRIVERS - see www.atos.com or KTI industrial master catalog

Drivers model	E-MI-AC		E-MI-AS-IR		E-BM-AS-PS		E-BM-AES
Type	analog		digital		digital		digital
Voltage supply (V _{dc})	12	24	12	24	12	24	24
Valve coil option	/6	std	/6	std	/6	std	std
Format	DIN 43650 plug-in to solenoid				DIN-rail panel		
Data sheet	G010		G020		G030		GS050

3 HYDRAULIC CHARACTERISTICS (based on mineral oil ISO VG 46 at 50 °C)

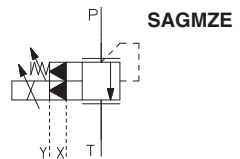
Hydraulic symbols			
Assembly position / location	Any position		
Subplate surface finishing	Roughness index Ra 0,4 - flatness ratio 0,01/100 (ISO 1101)		
MTTFd values according to EN ISO 13849	75 years, for further details see technical table P007		
Ambient temperature range	Standard and /PE = -20°C ÷ +70°C; /BT option = -40°C ÷ +60°C		
Storage temperature range	Standard and /PE = -20°C ÷ +80°C; /BT option = -40°C ÷ +70°C		
Coil code	Standard standard coil to be used with Atos drivers with power supply 24Vdc	option /6 optional coil to be used with Atos drivers with power supply 12 Vdc	option /18 optional coil to be used with electronic drivers not supplied by Atos, with power supply 24 Vdc
Coil resistance R at 20°C	3,1 Ω	2,1 Ω	13,1 Ω
Max. solenoid current	2,5 A	3 A	1,2 A
Protection degree (CEI EN-60529)	IP 65 (with connectors 666 correctly assembled)		
Duty factor	Continuous rating (ED=100%)		

Valve size	10	20	32
Max regulated pressure	50; 100; 210; 315; 350		
Min. regulated pressure [bar]	see min. pressure / flow diagrams at sect. 7		
Max. pressure at port P [bar]	350		
Max. pressure at port T [bar]	210		
Max. flow [l/min]	200	400	600
Response time 0-100% step signal (1) (depending on installation) [ms]	≤ 120	≤ 135	≤ 150
Hysteresis [% of the max pressure]	≤ 0,5		
Linearity [% of the max pressure]	≤ 1,0		
Repeatability [% of the max pressure]	≤ 0,2		

Notes: above performance data refer to valves coupled with Atos electronic drivers, see section 2.

(1) Average response time values; the pressure variation in consequence of a modification of the reference input signal to the valve is affected by the stiffness of the hydraulic circuit: greater is the stiffness of the circuit, faster is the dynamic response.

4 SEALS AND HYDRAULIC FLUID - for other fluids not included in below table, consult our technical office

Seals, recommended fluid temperature	NBR seals (standard) = -20°C ÷ +80°C, with HFC hydraulic fluids = -20°C ÷ +50°C FKM seals (/PE option) = -20°C ÷ +80°C HNBR seals (/BT option) = -40°C ÷ +60°C, with HFC hydraulic fluids = -40°C ÷ +50°C		
Recommended viscosity	20 ÷ 100 mm ² /s - max allowed range 15 ÷ 380 mm ² /s		
Max fluid contamination level	normal operation longer life	ISO4406 class 18/16/13 NAS1638 class 7 ISO4406 class 16/14/11 NAS1638 class 5	see also filter section at www.atos.com or KTF catalog
Hydraulic fluid	Suitable seals type	Classification	Ref. Standard
Mineral oils	NBR, FKM, HNBR	HL, HLP, HLPD, HVLP, HVLDP	DIN 51524
Flame resistant without water	FKM	HFDU, HFDR	ISO 12922
Flame resistant with water	NBR, HNBR	HFC	

5 GENERAL NOTES

SAGMZE proportional valves are CE marked according to the applicable Directives (e.g. Immunity/Emission EMC Directive and Low Voltage Directive).

6 SOLENOID CONNECTIONS

SOLENOID POWER SUPPLY CONNECTOR TYPE 666	
PIN	Signal description
1	SUPPLY
2	SUPPLY
3	GND

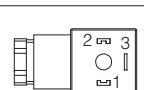

7 DIAGRAMS (based on mineral oil ISO VG 46 at 50 °C)

1 = Regulation diagrams
with flow rate Q = 50 l/min

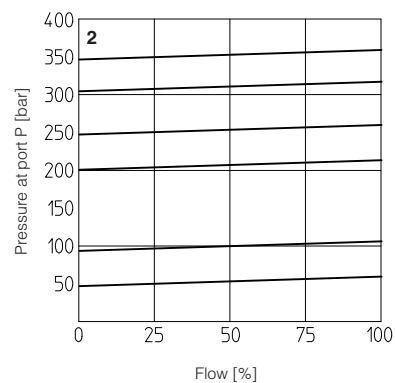
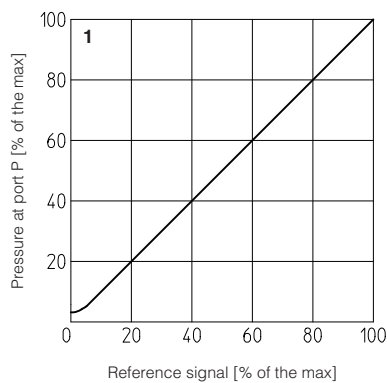

2 = Pressure/flow diagrams
with reference signal set at Q = 50 l/min

3-8 = Min. pressure/flow diagrams
with zero reference signal

- 3 = SAGMZE-A-10/50, 100, 210, 315
- 4 = SAGMZE-A-10/350
- 5 = SAGMZE-A-20/50, 100, 210, 315
- 6 = SAGMZE-A-20/350
- 7 = SAGMZE-A-32/50, 100, 210, 315
- 8 = SAGMZE-A-32/350

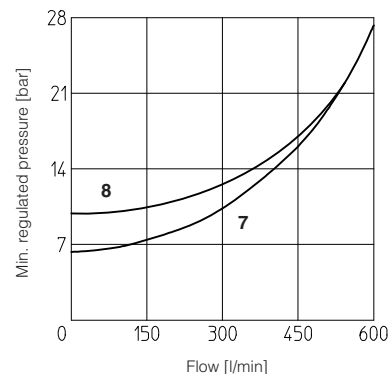
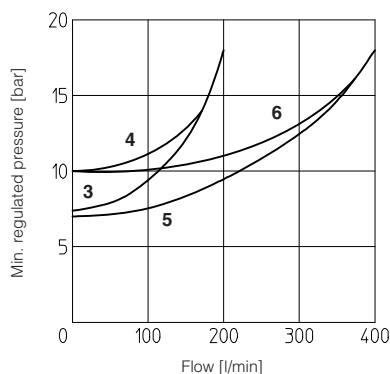

8 HYDRAULIC OPTIONS

8.1 Option E

External pilot option to be selected when the pilot pressure is supplied from a different line respect to the P main line.

With option E the internal connection between port P and X of the valve is plugged.

The pilot pressure must be connected to the X port available on the valve's mounting surface or on main body (threaded pipe connection G 1/4").

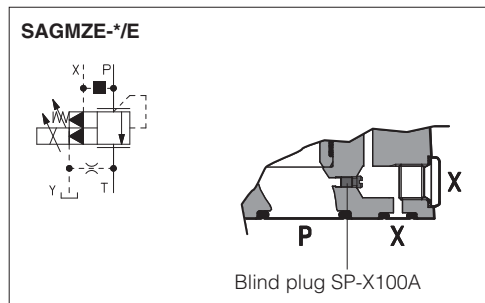

8.2 Option Y

The external drain is mandatory in case the main line T is subjected to pressure peaks or it is pressurized.

The Y drain port has a threaded connection G 1/4" available on the pilot stage body.

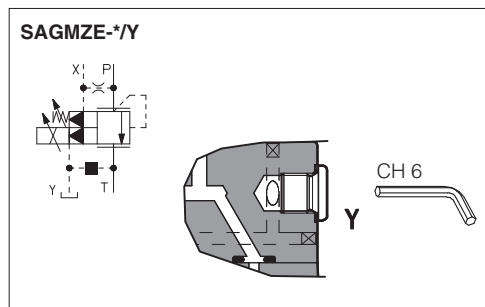

9 MECHANICAL PRESSURE LIMITER

The SAGMZE are provided with mechanical pressure limiter acting as protection against overpressure. For safety reasons the factory setting of the mechanical pressure limiter is fully unloaded (min pressure).

At the first commissioning it must be set at a value lightly higher than the max pressure regulated with the proportional control.

For the pressure setting of the mechanical pressure limiter, proceed according to following steps:

- apply the max reference input signal to the valve's driver. The system pressure will not increase until the mechanical pressure limiter remains unloaded.
- turn clockwise the adjustment screw ① until the system pressure will increase up to a stable value corresponding to the pressure setpoint at max reference input signal.
- turn clockwise the adjustment screw ① of additional 1 or 2 turns to ensure that the mechanical pressure limiter remains closed during the proportional valve working.

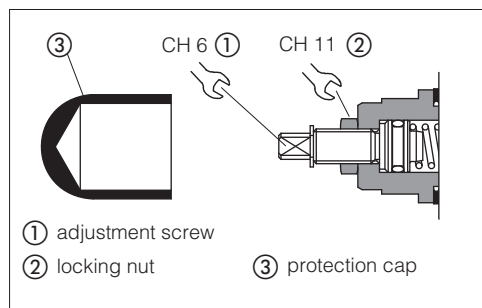

10 AIR BLEEDING

At the first valve commissioning the air eventually trapped inside the solenoid must be bled-off through the screw ① located at the rear side of the solenoid housing.

The presence of air may cause pressure instability and vibrations.

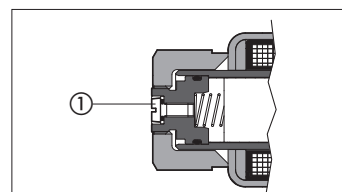

11 REMOTE PRESSURE UNLOADING

The **P** main line can be remotely unloaded by connecting the valve X port to a solenoid valve as shown in the below scheme (venting valve).

This function can be used in emergency to unload the system pressure by-passing the proportional control.

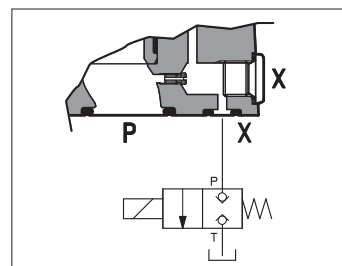

12 COILS TYPE WITH SPECIAL CONNECTORS

Options -J

Coil type COZEJ
AMP Junior Timer connector
Protection degreee IP67

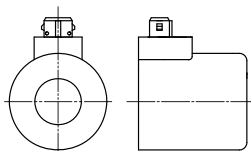

Options -K

Coil type COZEK
Deutsch connector, DT-04-2P male
Protection degreee IP67

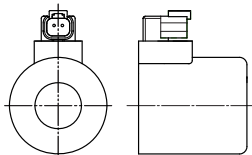

Options -S

Coil type COZES
Lead Wire connection
Cable lenght = 180 mm

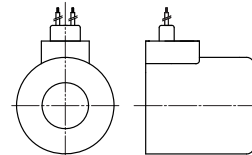

SIZE 10

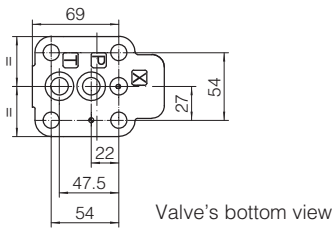

ISO 6264: 2007

Mounting surface: 6264-06-09-1-97

Fastening bolts:

4 socket head screws M12x35 class 12.9

Tightening torque = 125 Nm

Seals: 2 OR 123; 1 OR 109/70

Ports P, T: $\varnothing = 14,5$ mm

Port X: $\varnothing = 3,2$ mm

SAGMZE-A-10

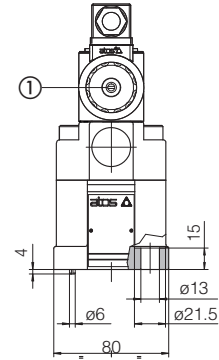
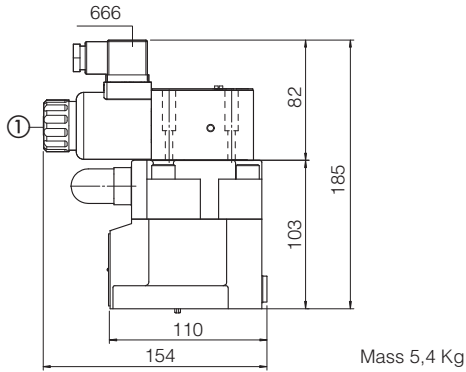

SIZE 20

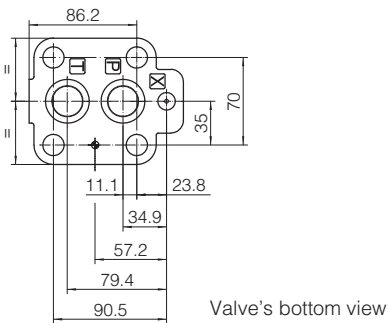

ISO 6264: 2007

Mounting surface: 6264-08-13-1-97

Fastening bolts: 4 socket head screws

M16x50 class 12.9

Tightening torque = 300 Nm

Seals: 2 OR 4112, 1 OR 109/70

Ports P, T: $\varnothing = 24$ mm

Port X: $\varnothing = 3,2$ mm

SAGMZE-A-20

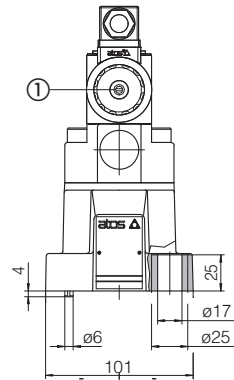
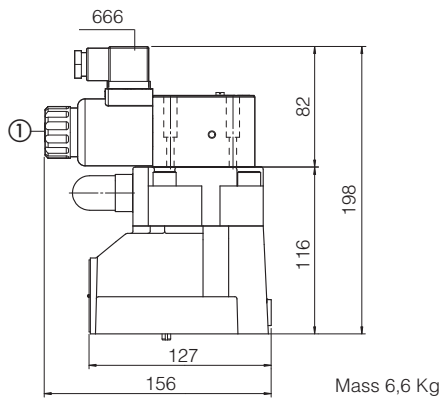

① = Screw for air bleeding

SIZE 32

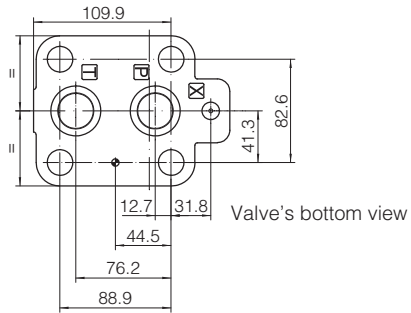

ISO 6264: 2007

Mounting surface: 6264-10-17-1-97

(with M20 fixing holes instead of standard M18)

Fastening bolts: 4 socket head screws

M20x60 class 12.9

Tightening torque = 600 Nm

Seals: 2 OR 4131, 1 OR 109/70

Ports P, T: $\varnothing = 28$ mm

Port X: $\varnothing = 3,2$ mm

Mass 8 Kg

SAGMZE-A-32

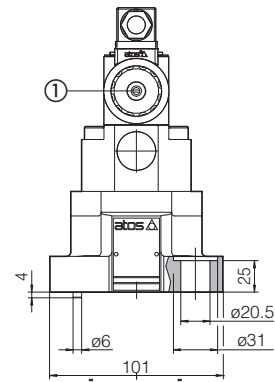
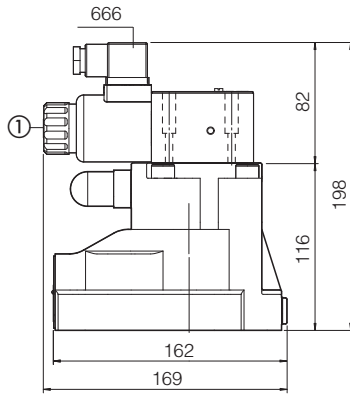

① = Screw for air bleeding