

Electronic drivers type E-ME-T-2*H

analog, Euro double card format, for proportional valves with transducer

Available only on request

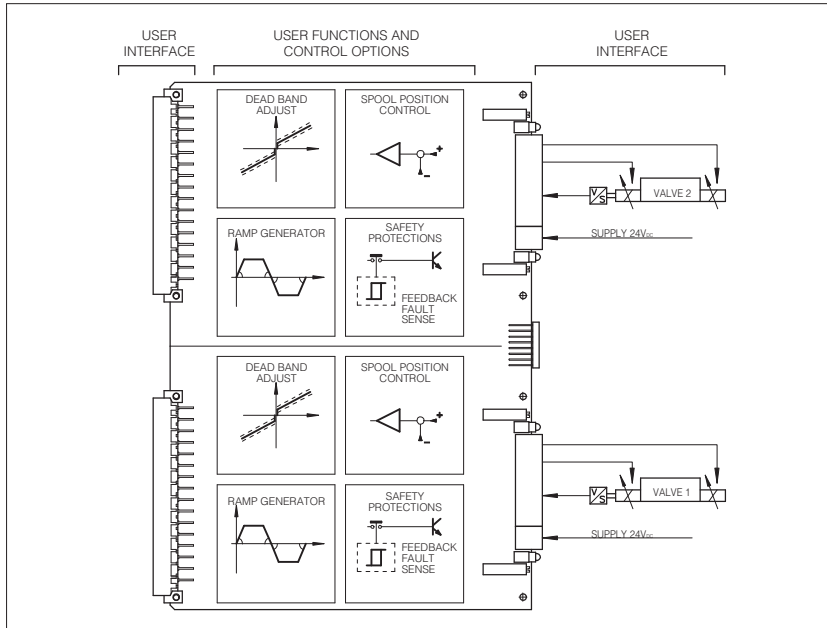

E-ME-T-2*H electronic drivers supply single and double solenoid proportional valves type ZO(R)-T with the correct current signal to align valve regulation to the error signal.

The driver operates the spool's position control proportionally to the input voltage reference signals supplying a switching current to the solenoids.

Bias adjustment is available for accurate valve regulations.

A typical application is the two-axes close-loop synchronization for bending presses.

This double driver is supplied already set, coupled with two suitable proportional valves, optimizing their performances.

The electronic driver is in Eurocard format (2 x DIN 4194 - Plug-in-units). A backplane connector is used to wire low-power signals (setpoints, enable, etc.). Valve coil, transducer and power supply wires (24V_{DC}) are connected on the front side by means of a terminal board connector.

This version includes the following improved features:

- electronic filters on input and output lines
- test point for reference and feedback on front panel

1 MODEL CODE

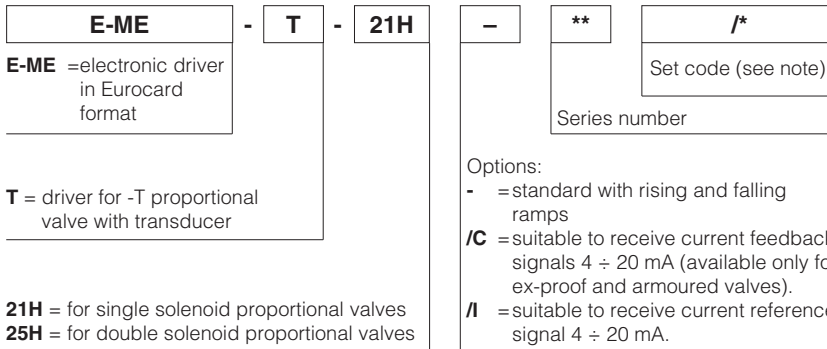

Note: The set code identifies the correspondence between the driver and the relevant proportional valve (see 4.4).

2 BLOCK DIAGRAM

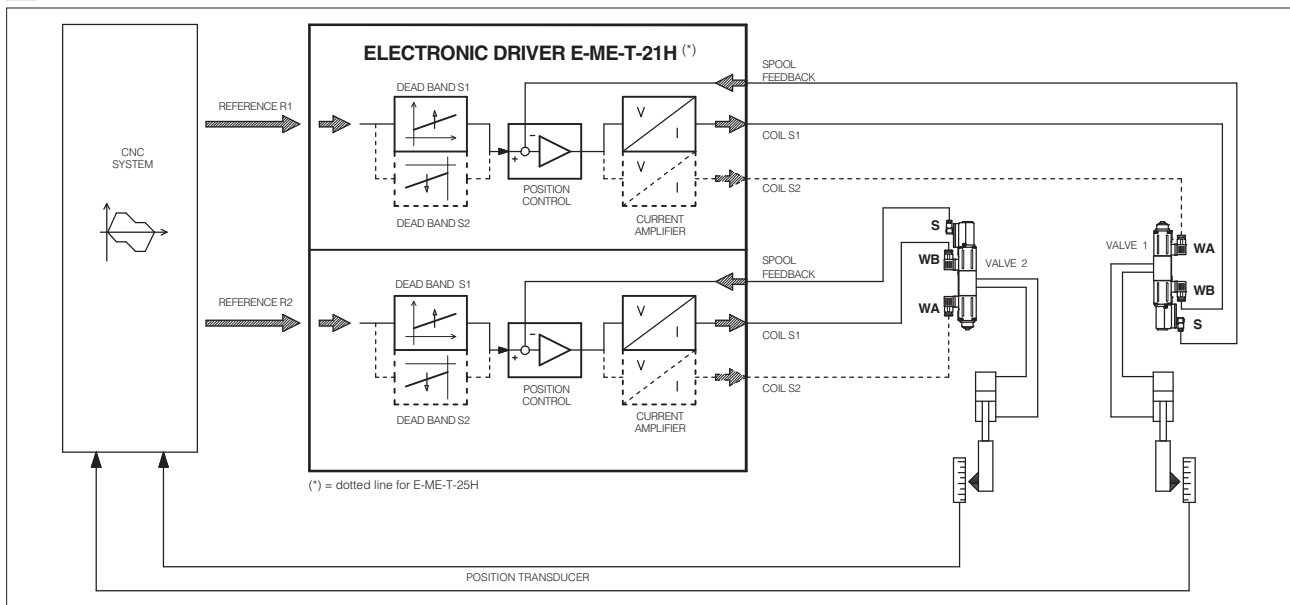

3 MAIN CHARACTERISTICS OF EACH SECTION OF E-ME-T-2*H ELECTRONIC DRIVERS

Power supply (see 4.1): plug connector on front panel with two contacts Contacts: positive 2a; negative 4a, 4c (see 10)	Nominal: +24 V _{DC} Rectified and filtered: V _{RMS} = 21 ÷ 28 V _{MAX} (ripple max 10 % V _{PP}) Smooth battery voltage (continuous) : 21 ÷ 40 V _{DC}
Max power consumption	50 W per valve
Current supplied to solenoids	I _{MAX} = 3,3 A square wave PWM type (with solenoid type ZO-T with resistance 3,2 Ω) I _{MAX} = 2,5 A square wave PWM type (with explosion-proof solenoid with resistance 3,2 Ω)
Nominal reference signal	±10 V differential amplifier at contact 20c (+) and 20a (-)
Input signal impedance	Voltage R _i > 50 kΩ
Reference voltage for external electronics	-10 V / 10 mA from 32c contact +10 V / 10 mA from 32a contact
Enabling signal	V = 6 ÷ 40 V _{DC} on contact 16a with led indicator on front panel; R _i ≥ 30 kΩ (max 3 mA)
Cable break fault alarm (22a)	Active low; no alarm: +24 V _{DC} (max 100 mA)
Valve electrical wirings screw type 8 pin plug connector on front panel (plug included)	Coil: S1 contacts 3,4 2 x 1 mm ² up to 20 m - 2 x 1,5 mm ² shielded up to 40 m S1 contacts 5,6 Transducer: -15 V contact 7 +15 V contact 8 rif. 0 V contact 9 signal contact 10 4 x 0,25 mm ² up to 20 m - 4 x 0,5 mm ² shielded up to 40 m
Card format	Double Eurocard 233,4 x 160 x 40 mm (width x length x height) (Plug-in unit DIN 41494)
Back card connector	Male DIN 41612 /D
Connector elements available	Type E-K-32M/2 card holder/screw connections (see table G800) to be ordered separately
Operating temperature	0 ÷ 50 °C (storage -20 ÷ 70 °C)
Total mass	430 g (without front panel)
Features	Position control by PID action - Fast solenoid excitation and switching off. Outputs to solenoids protected against accidental short circuits. Feedback cable break produces an inhibition of the driver, zeroing the current and creating a fail-safe position in the valve. Diagnostic state of the valve spool position.

4 GENERAL SPECIFICATIONS

4.1 Power supply and wirings for each regulator

The power supply must be appropriately stabilized or rectified and filtered (use a 4700µF/63V capacitor when ripple > 10%). Never insert or remove the driver while the electronic system is powered on.

The driver is protected against overloads by an internal safety fuse: 4 A fast fuse (see 7).

4.2 Reference signal

The electronic driver is designed to receive external voltage reference signals according to 10, 11. Connect the electronic driver according to 5, 11, 12.

4.3 Set code

Basic calibration of the electronic driver is factory preset according to proportional valve it has to be coupled with. The two drivers on the card E-ME-T-2*H are supplied with the same basic calibration. These pre-calibrations are identified by a standard number in the model code.

For correct set code selection, please include in the driver order also the complete code of the connected proportional valve (for **ex-proof valves** see tables F600, E125).

For further information about set code, please contact Atos technical office.

4.4 Calibration/settings accessible to the user

– Scale

The relation between the driving current and the reference signal is fixed. For single solenoid valves with two external operating positions (-*60, -*40), the reference signal is ±10V (the same as double solenoid valve). Only for particular requirements a separate scale adjust for solenoid S1 and S2 (internal potentiometers P7, P16 for solenoid S1 and P8, P17 for solenoid S2) to obtain differential hydraulic operations in particular working conditions (see 7).

– Bias (dead band compensation), see 8, 9

Regulation of dead band adjust the hydraulic zero of the valve (adjustment of starting position) to the corresponding electrical zero. The electronic card is factory preset for the valve it is coupled with according to the set code (see section 4.3). For double solenoid driver E-ME-T-25H/* a step function generator becomes active when the input reference voltage signal is greater than ±200mV enabling start current set by front panel bias potentiometers P1 and P2 for independent dead band regulation.

5 EXT. REFERENCE SIGNALS R1, R2

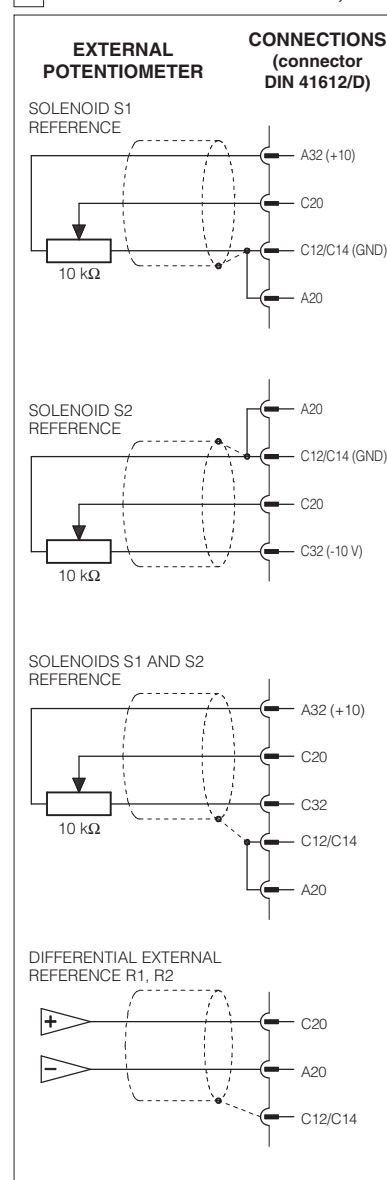

6 INSTALLATION AND START-UP

It is advisable to perform calibration procedures in the order given below.

6.1 Warning:

- Never insert or remove the driver while the electronic system is powered on.
- Voltages must always be measured with reference to GND (test point TP2).
- Refer to [7], [8] to identify components mentioned in calibration procedures.

6.2 Start-up

The operations described here follow must be applied to each driver on the card. Factory preset adjustment may not meet the desired requirements for the specific application and performances can be optimized by on-site re-adjustments of bias and scale potentiometers, in sequence. Connect each electronic driver according to the desired connection diagram (see [10], [11], [12]).

- Enabling signal, see [10], [11]

The electronic driver operate when the contact 16a is supplied with an enabling signal (usually $24V_{DC}$). It could be useful in emergency conditions to inhibit the driver by zeroing this signal (enable led off).

- Bias adjustment (dead band compensation), see [8], [9], [10]

For version E-ME-T-21H:

- supply a reference signal voltage $0 V_{DC}$
- gradually operate the potentiometer P1 until stop of the controlled actuator is obtained

For version E-ME-T-25H:

- supply a reference signal voltage $+0,2 V_{DC}$
- gradually turn clockwise the potentiometer P1 for solenoid S1 until a movement of the controlled actuator is obtained
- gradually turn in the opposite sense the potentiometer P1 until stop of the controlled actuator is obtained
- repeat the operation and supply a reference signal voltage $-0,2 V_{DC}$ by the potentiometer P2

- Scale adjustment, see [8], [9], [10]

Factory preset reference signal is $0 \div +10V$ for E-ME-T-21H and $\pm 10V$ for E-ME-T-25H (see 4.4). Only in particular cases when a non standard reference signal is available it is possible to adjust maximum valve opening with scale regulation proceeding as follow:

- supply a $+10 V_{DC}$ reference signal (for E-ME-T-25H repeat the operation for $-10 V_{DC}$ reference signal) and, if it is necessary, turn counterclockwise the internal scale potentiometers P7, P16 and P8, P17 (factory preset to 100%) to reduce valve opening (see [7])

7 E-ME-T-2*H TOPOGRAPHICAL VIEW

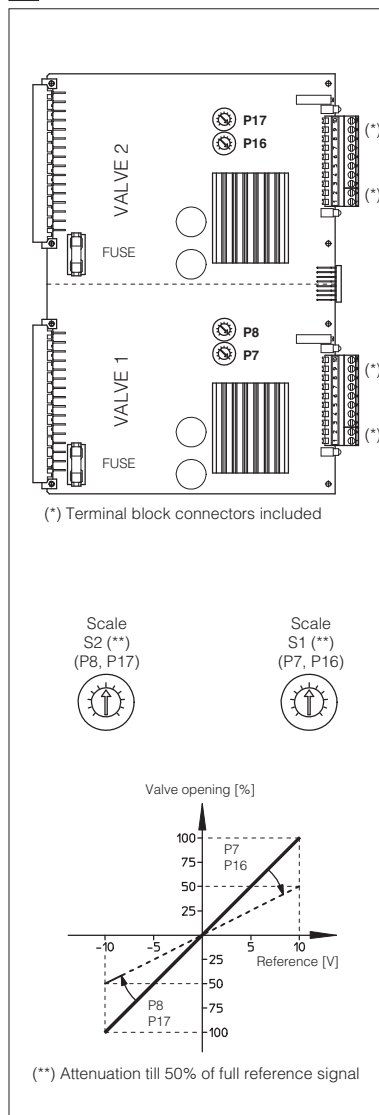

8 E-ME-T*-25H TOPOGRAPHICAL VIEW OF REGULATIONS

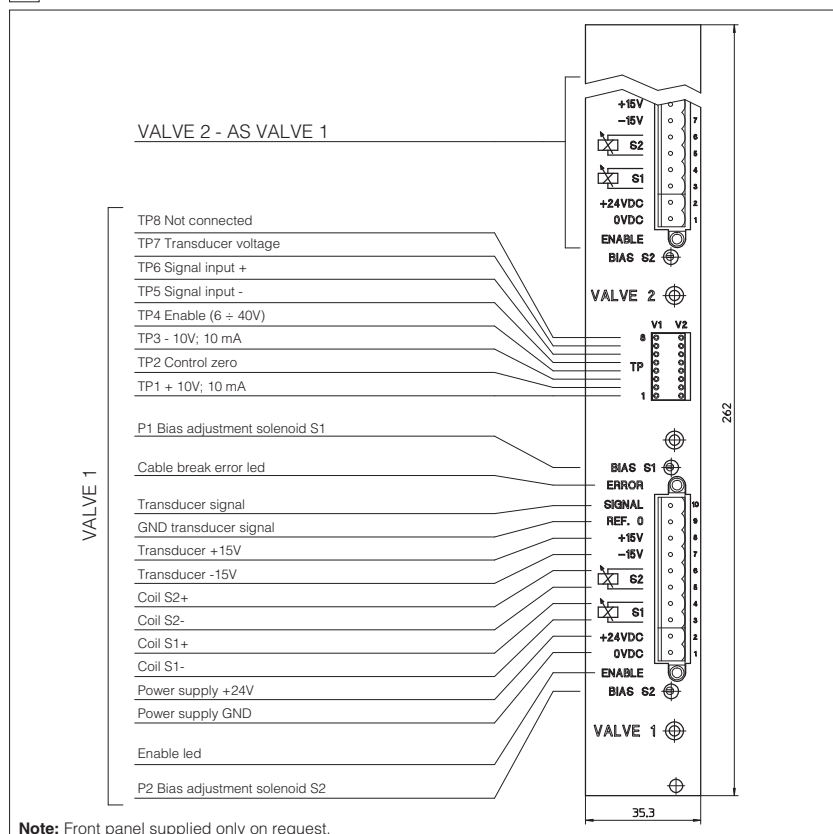

9 E-ME-T-2*H DIAGRAM

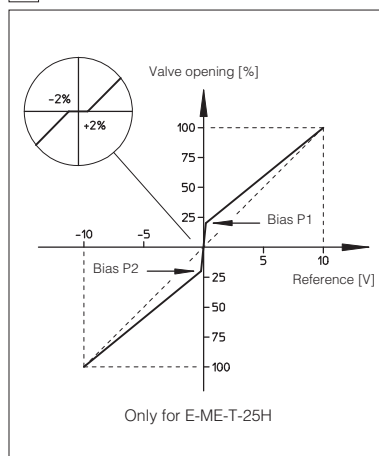

10 WIRING BLOCK DIAGRAM (for each electronic driver)

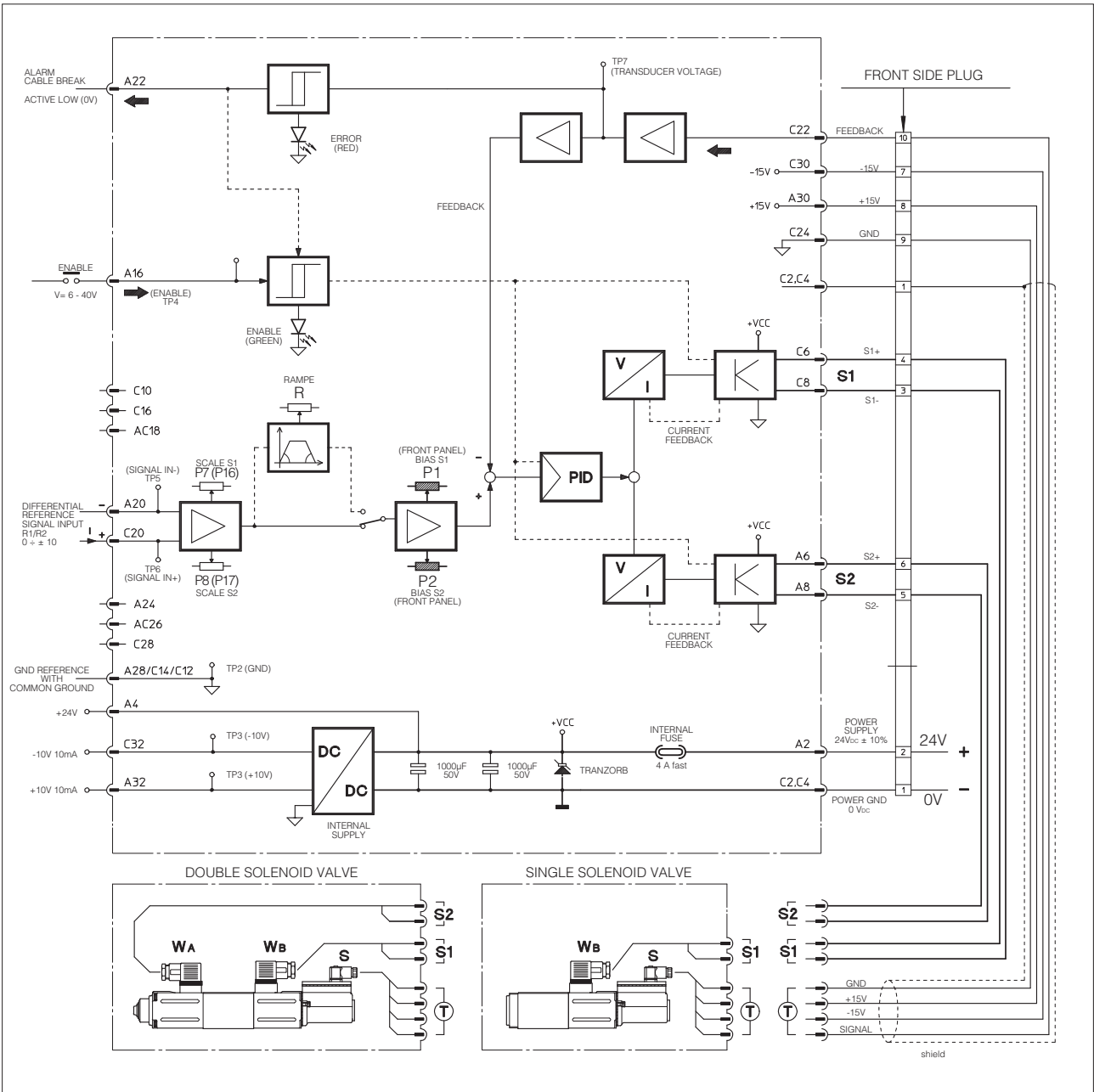

11 REAR CONNECTIONS FOR EACH SECTION

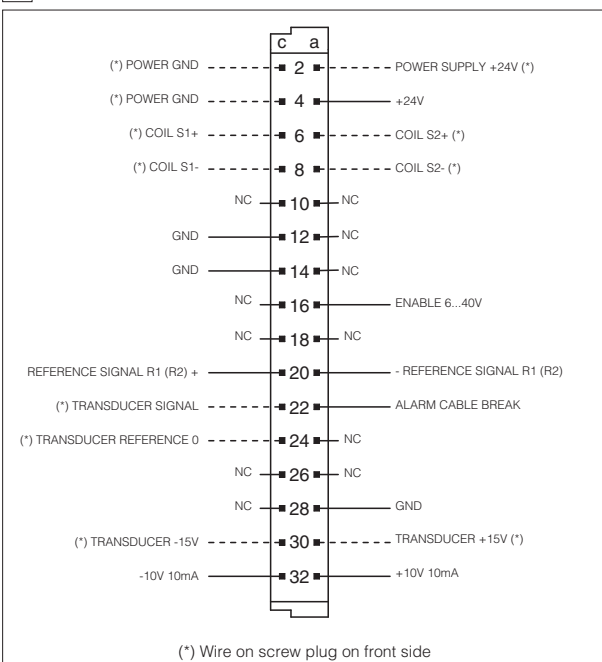

12 FRONT PANEL CONNECTIONS FOR EACH SECTION

