

On-off explosion-proof valves with MA certification

Directional, ISO 4401 size 06 and 10 (direct), 16 and 25 (two stage)

Pressure relief, ISO 6264, size 10, 20 and 32

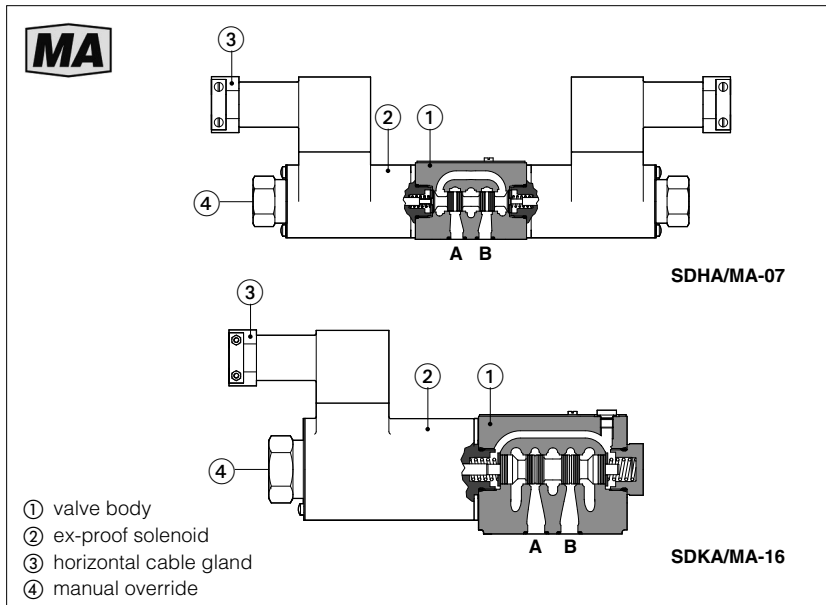

Directional and pilot operated pressure relief valves equipped with explosion-proof solenoids certified according to **MA** Chinese mining certification, protection mode:

Ex d I Mb for surface, tunnel or mine plants

The solenoids are provided with cable glands (horizontally oriented) for cable entrance and internal terminal board for power supply coils connections.

The solenoid case classified **Ex d** is designed to contain the possible explosion which could be caused by the presence of the gas mixture inside the housing, thus avoiding dangerous propagation in the external environment.

They are also designed to limit the external temperature according to the certified class to avoid the self ignition of the explosive mixture present in the environment.

SDHA /MA: directional, direct, size 06

SDKA /MA: directional, direct, size 10

SDPHA /MA: directional, two stage, size 16 and 25

SAGAM /MA: pressure relief, size 10, 20 and 32

1 EXPLOSION PROOF SOLENOIDS: MAIN DATA

SOLENOID TYPE	ON/OFF	
Voltage code VDC ±10%	12DC, 24DC, 110DC	
Power consumption	16,5 W (SDHA, SDPHA, SAGAM)	18W (SDKA)
Method of protection	Ex d	
Temperature class	T4	
Surface temperature	≤135 °C	
Ambient temperature	-20 ÷ +40 °C	
Protection degree	IP 65	
Duty factor	100%	
Mechanical construction	Flame proof housing classified Ex d	
Cable entrance and electrical wiring	Horizontal cable gland, internal terminal board for cable connection, see section 3	
MA Certification	Ex d = Equipment for explosive atmosphere, flame proof housing I = Gas group (Methane) Mb = Equipment protection, high level protection for explosive atmospheres	
Operating pressure	SDHA/MA	P, A, B = 350 bar T = 210 bar
	SDKA/MA	P, A, B = 315 bar T = 210 bar
	SDPHA/MA	P, A, B, X = 350 bar T = 250 bar (standard) T = 210 bar (option /D) Ports Y = 0 bar - Minimum pilot pressure for correct operation is 8 bar
	SAGAM/MA	P, X = 350 bar T, Y = 210 bar
Maximum flow	SDHA/MA	80 l/min
	SDKA/MA	120 l/min
	SDPHA/MA	SDPHA-2: 300 l/min ; SDPHA-4: 700 l/min ;
	SAGAM/MA	SAGAM/MA-10 = 200 l/min ; SAGAM/MA-20 = 400 l/min ; SAGAM/MA-32 = 600 l/min ;

2 MAIN CHARACTERISTICS, SEALS AND HYDRAULIC FLUID - for other fluids not included in below table, consult our technical office

Assembly position / location	Any position for all valves		
Subplate surface finishing	Roughness index Ra 0,4 - flatness ratio 0,01/100 (ISO 1101)		
Seals, recommended fluid temperature	NBR seals (standard) = -20°C ÷ +80°C, with HFC hydraulic fluids = -20°C ÷ +50°C FKM seals (/PE option) = -20°C ÷ +80°C		
Recommended viscosity	15 ÷ 100 mm ² /s - max allowed range 2.8 ÷ 500 mm ² /s		
Max fluid contamination level	ISO4406 class 20/18/15 NAS1638 class 9, see also filter section at www.atos.com or KTF catalog		
Hydraulic fluid	Suitable seals type	Classification	Ref. Standard
Mineral oils	NBR, FKM, HNBR	HL, HLP, HLPD, HVLP, HVLPD	DIN 51524
Flame resistant without water	FKM	HFDU, HFDR	ISO 12922
Flame resistant with water	NBR, HNBR	HFC	

3 SOLENOID WIRING

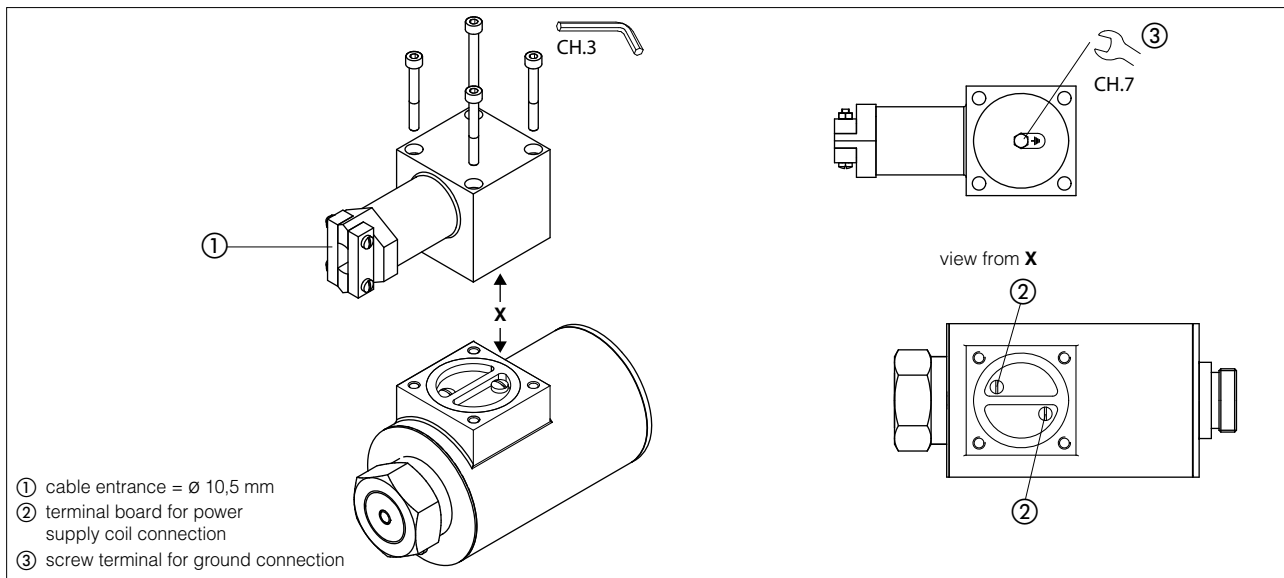

4 MODEL CODE OF DIRECT SOLENOID VALVES TYPE SDHA, SDKA

SDHA	/	MA	-	0	63	1/2	/	A	24DC	**	**
<p>SDHA = spool type - direct, size 06 SDKA = spool type - direct, size 10</p> <p>MA = Ex-proof Ma Chinese mining certification</p> <p>0 = size 06 for SDHA 1 = size 10 for SDKA</p> <p>Valve configuration, see section 5</p> <p>Spool type, see section 5</p>											
<p>Option: A = solenoid at side of port B (for single solenoid valves)</p>										<p>Seals material, see sect. 2: - = NBR PE = FKM</p> <p>Series number</p>	
<p>Voltage code - see section 1</p>										<p>Series number</p>	

5 CONFIGURATIONS and SPOOLS (representation according to ISO 1219-1)

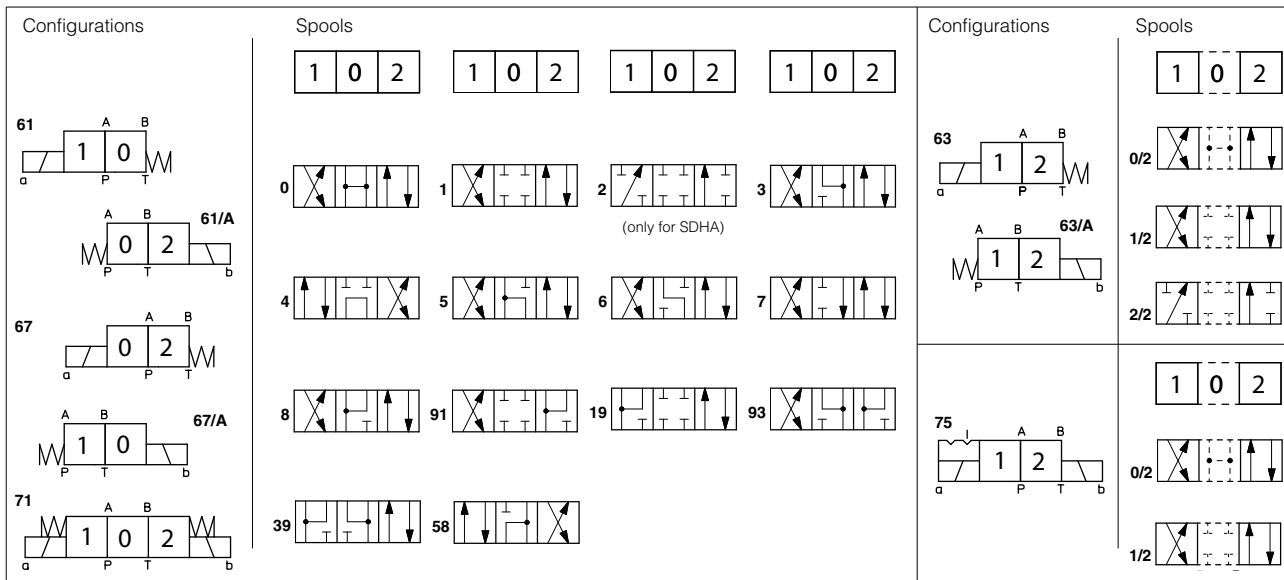

SDHA spools **1, 4, 5** and **58** are also available as **1/1, 4/8, 5/1** and **58/1**. They are properly shaped to reduce water-hammer shocks during the switching.
SDKA spool **1** is also available as **1/1**. It is properly shaped to reduce water-hammer shocks during the switching.

6 Q/ΔP DIAGRAMS based on mineral oil ISO VG 46 at 50°C

SDHA

Flow direction Spool type	Flow direction				
	P→A	P→B	A→T	B→T	P→T
0, 0/1	A	A	C	C	D
1, 1/1	D	C	C	C	
3, 3/1	D	D	A	A	
4, 4/8, 5, 5/1, 58, 58/1 19, 91, 93, 39	F	F	G	C	E
1/2, 0/2	D	D	D	D	
6, 7	D	D	D	D	
8	A	A	E	E	
2	D	D			
2/2	F	F			

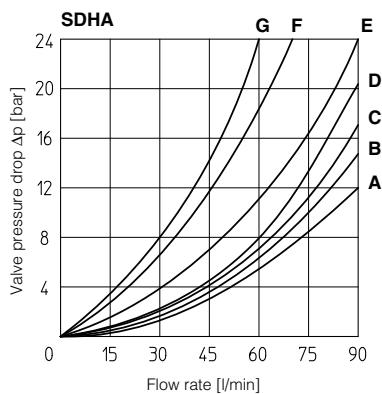

SDKA

Flow direction Spool type	Flow direction					
	P→A	P→B	A→T	B→T	P→T	B→A
0, 0/1, 0/2, 2/2	A	A	B	B		
1, 1/1, 1/3, 6, 8	A	A	D	C		
3, 3/1, 7	A	A	C	D		
4	B	B	B	B	F	
5	A	B	C	C	G	
1/2	B	C	C	B		
19	A	D	C			H

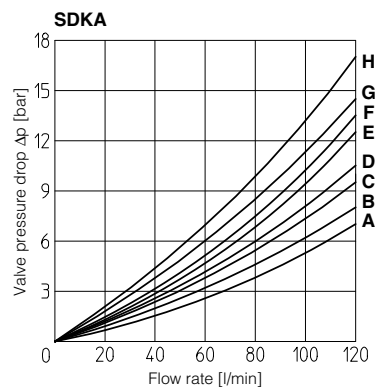

7 OPERATING LIMITS For a correct valve operation do not exceed the max recommended flow rates (l/min) shown in the below tables

SDHA

- A** = Spools 0, 0/1, 1, 1/2, 3, 8
- B** = Spools 0/2, 1/1, 6, 7
- C** = Spools 3/1, 4, 4/8, 5, 5/1, 19, 39, 58, 58/1, 09, 90, 91, 93, 94
- D** = Spools 2, 2/2

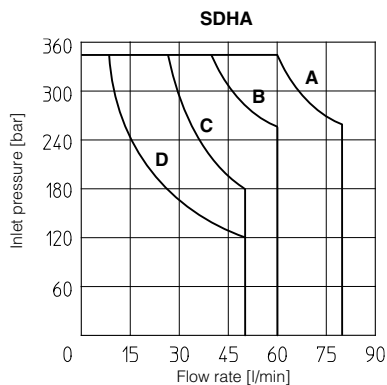

SDKA

- M** = Spools 0, 0/1, 1, 1/1, 3, 3/1, 1/2, 0/2, 8
- S** = Spools 1/3, 6, 7
- Y** = Spools 4, 5
- V** = Spools 2/2
- T** = Spools 19

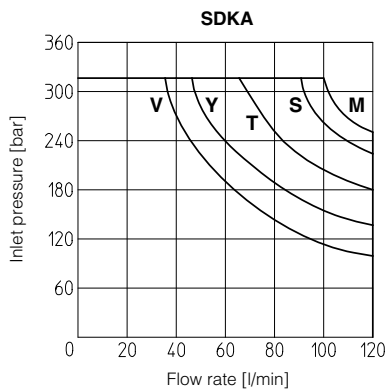

8 MODEL CODE OF PILOTED SOLENOID VALVES TYPE SDPHA

<p>SDPHA</p> <p>SDPHA = spool type - piloted</p> <p>MA = Ex-proof Ma Chinese mining certification</p> <p>Valve size (ISO 4401) 2 = 16 4 = 25</p> <p>Valve configuration, see section 9</p> <p>Spool type, see section 9</p>	/	<p>MA</p>	-	<p>2</p>	<p>63</p>	<p>1/2</p>	-	<p>A</p>	<p>24DC</p> <p>Voltage code - see section 1</p>	<p>**</p> <p>Series number</p>	<p>I*</p> <p>Seals material: omit for NBR (mineral oil & water glycol) PE = FPM</p>
---	---	------------------	---	-----------------	------------------	-------------------	---	-----------------	--	---------------------------------------	---

Options:

- /A = Solenoid at side of port B (for single solenoid valves)
- /D = Internal drain
- /E = External pilot pressure
- /H = Adjustable chokes (meter-out to the pilot chambers of the main valve)
- /R = pilot pressure generator (4 bar on port P)
- /S = Main spool stroke adjustment

9 CONFIGURATIONS and SPOOLS (representation according to ISO 1219-1)

<p>Configurations</p> <p>Spools</p> <p>Spools type 0 and 3 are also available as 0/1 and 3/1 with restricted oil passages in central position, from user ports to tank.</p> <p>Spools type 1 and 4 are also available as 1/1 and 4/8 that are properly shaped to reduce water-hammer shocks during the switching.</p>	<p>Configurations</p> <p>Spools</p>
---	---

10 Q/ΔP DIAGRAMS based on mineral oil ISO VG 46 at 50°C

SDPHA-2

Spool type	Flow direction				
	P→A	P→B	A→T	B→T	P→T
0/2, 1, 3, 6, 7, 8	A	A	D	A	-
1/1, 1/2, 7/1	B	B	D	E	-
0	A	A	D	E	C
0/1	A	A	D	-	-
2	A	A	-	-	-
2/2	B	B	-	-	-
3/1	A	A	D	D	-
4	C	C	H	I	F
4/8	C	C	G	I	F
5	A	B	F	H	G
5/1	A	B	D	F	-
6/1	B	B	C	E	-
19	C	-	-	G	-
39	C	-	-	H	-
91	C	C	E	-	-
93	-	C	D	-	-

SDPHA-4

Spool type	Flow direction				
	P→A	P→B	A→T	B→T	P→T
1	B	B	B	D	-
1/1	D	E	E	F	-
1/2	E	D	B	C	-
0	D	C	D	E	F
0/1, 3/1, 5/1, 6, 7	D	D	D	F	-
0/2	D	D	D	E	-
2	B	B	-	-	-
2/2	E	D	-	-	-
3	B	B	D	F	-
4	C	C	H	L	L
5	A	D	D	D	H
6/1	D	E	D	F	-
7/1	D	E	F	F	-
8	D	D	E	F	-
19	F	-	-	E	-
39	G	F	-	F	-
91	F	F	D	-	-
93	-	G	D	-	-

SDPHA-2

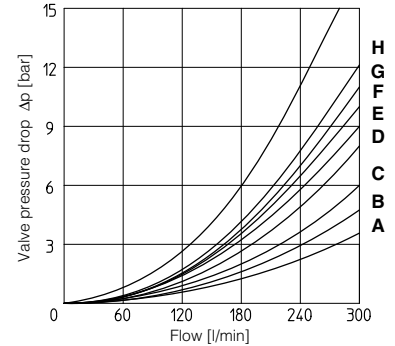

SDPHA-4

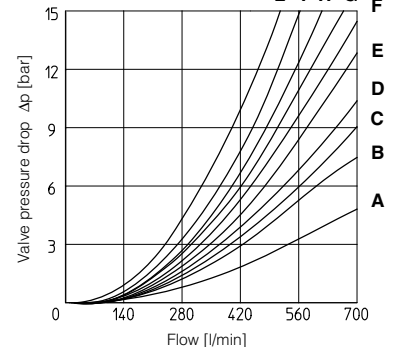

11 OPERATING LIMITS For a correct valve operation do not exceed the max recommended flow rates (l/min) shown in the below tables

SDPHA-2

Spool	Inlet pressure [bar]			
	70	140	210	350
	Flow rate [l/min]			
0, 1, 3, 6, 7, 8	300	300	300	250
2, 4, 4/8	300	300	240	140
5	260	220	180	100
0/1, 0/2, 1/2	300	250	210	180
16, 17, 56, *9, 9*	300	300	270	200

SDPHA-4

Spool	Inlet pressure [bar]			
	70	140	210	350
	Flow rate [l/min]			
1, 6, 7, 8	700	700	700	600
2, 4, 4/8	500	500	450	400
5, 0/1, 0/2, 1/2	600	520	400	300
0, 3	700	700	600	540
16, 17, 58, *9, 9*	500	500	500	450

12 MODEL CODE OF PRESSURE RELIEF VALVES TYPE SAGAM

<p>SAGAM</p> <p>SAGAM = pressure relief valve: subplate mounting</p> <p>MA = ex-proof MA chinese mining certification</p> <p>Valve size: 10 (ISO 6264) 20 (ISO 6264) 32 (ISO 6264)</p> <p>1 = one setting pressure</p> <p>Valve configuration, see section 13 0 = venting with de-energized solenoid 1 = venting with energized solenoid</p>	/	<p>MA</p>	-	<p>20</p>	/	<p>1</p>	/	<p>0</p>	/	<p>210</p>	-	<p>*</p>	/	<p>24DC</p>	/	<p>**</p>	/	<p>*</p>
<div style="float: right; border: 1px solid black; padding: 5px; margin-bottom: 10px;"> Seals material, see section 2: - = NBR PE = FKM </div> <p style="text-align: right;">Series number</p> <hr/> <p style="text-align: right;">Voltage code - see section 11</p> <p>Options: V = regulating handweel</p> <p>Max regulated pressure: 50 = 50 bar 210 = 210 bar 100 = 100 bar 350 = 210 bar</p>																		

13 HYDRAULIC SYMBOL



14 REGULATED PRESSURE VERSUS FLOW DIAGRAMS based on mineral oil ISO VG 46 at 50°C

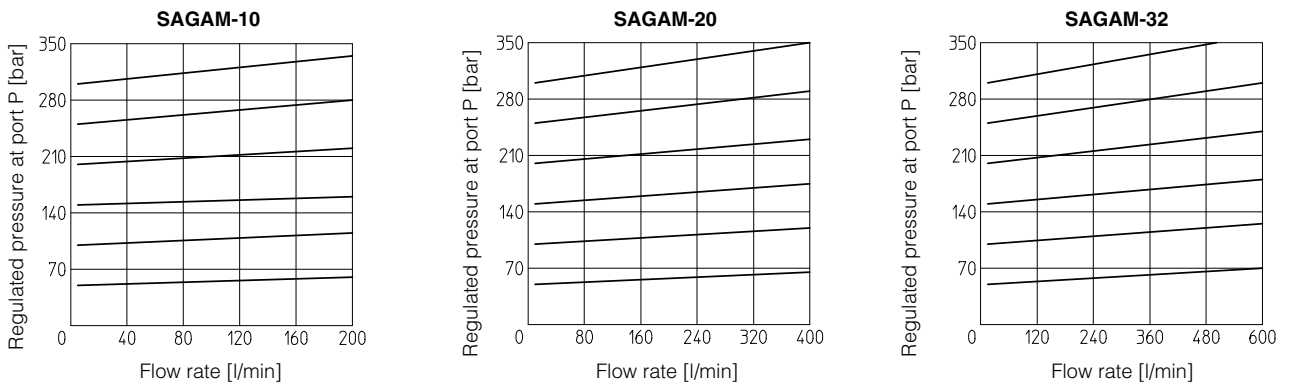

15 MINIMUM PRESSURE VERSUS FLOW DIAGRAMS based on mineral oil ISO VG 46 at 50°C

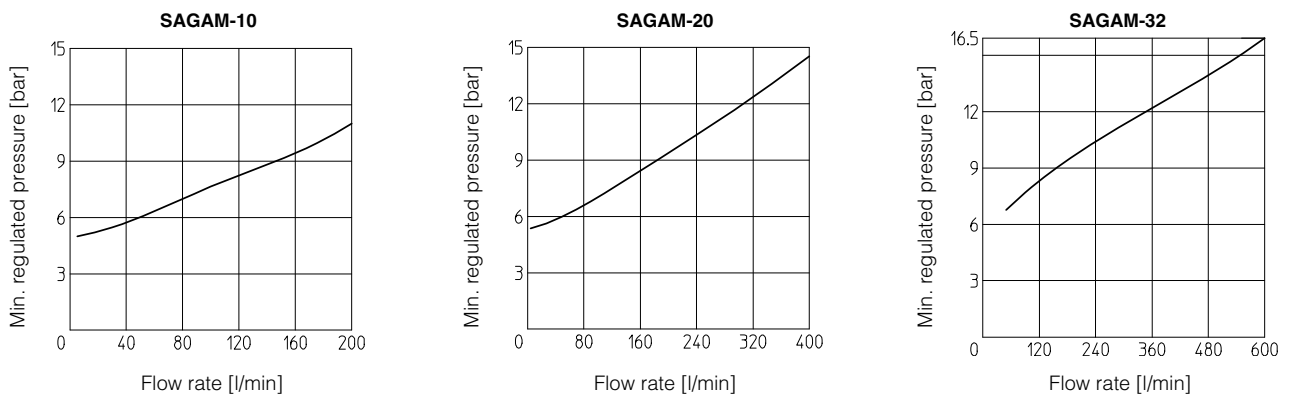

SDHA/MA

ISO 4401: 2005

Mounting surface: 4401-03-02-0-05

Fastening bolts: 4 socket head screws:

M5x30 class 12.9

Tightening torque = 8 Nm

Seals: 4 OR 108

Ports P,A,B,T: $\varnothing = 7.5$ mm (max)

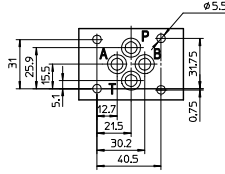

P = PRESSURE PORT
A, B = USE PORT
T = TANK PORT

SDHA/MA-06

SDHA/MA-07 (dotted line)

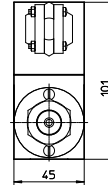
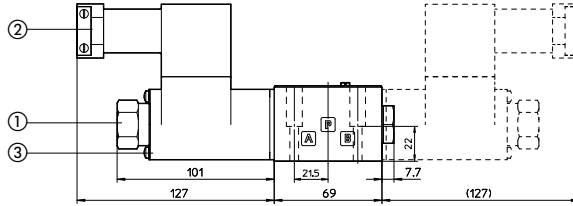

Mass of basic versions:
 SDHA/MA-06: 3,2 kg
 SDHA/MA-07: 4,9 kg

- ① manual override
- ② horizontal cable gland, cable entrance = $\varnothing 10,5$ mm
- ③ screw terminal for additional equipotential grounding

SDKA/MA

ISO 4401: 2005

Mounting surface according to 4401-05-05-0-05
 (without X port, Y port optional)

Fastening bolts:

4 socket head screws M6x40 class 12.9

Tightening torque = 15 Nm

Seals: 5 OR 2050 and 1 OR 108

Ports P,A,B,T: $\varnothing = 11,5$ mm (max)

Ports Y: $\varnothing = 5$ mm

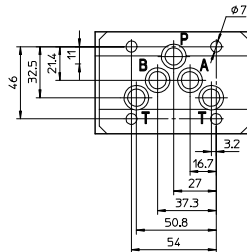

P = PRESSURE PORT
A, B = USE PORT
T = TANK PORT

SDKA/MA-16

SDKA/MA-07 (dotted line)

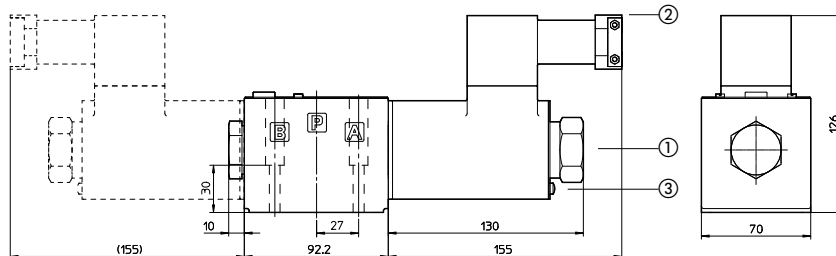

Mass of basic versions:
 SDKA/MA-16: 5,7 kg
 SDKA/MA-17: 8,7 kg

- ① manual override
- ② horizontal cable gland, cable entrance = $\varnothing 10,5$ mm
- ③ screw terminal for additional equipotential grounding

SDPHA/MA-2

ISO 4401: 2005

Mounting surface: 4401-07-07-0-05

Fastening bolts:
 4 socket head screws M10x50 class 12.9
 Tightening torque = 70 Nm
 2 socket head screws M6x45 class 12.9
 Tightening torque = 15 Nm
 Diameter of ports A, B, P, T: $\varnothing = 20$ mm;
 Diameter of ports X, Y: $\varnothing = 7$ mm;
 Seals: 4 OR 130, 2 OR 2043

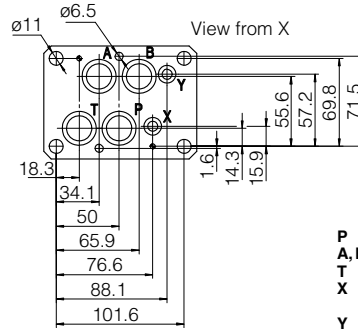

P = PRESSURE PORT
A, B = USE PORT
T = TANK PORT
X = EXTERNAL OIL PILOT PORT
Y = DRAIN PORT

SDPHA/MA-26

SDPHA/MA-27 (dotted line)

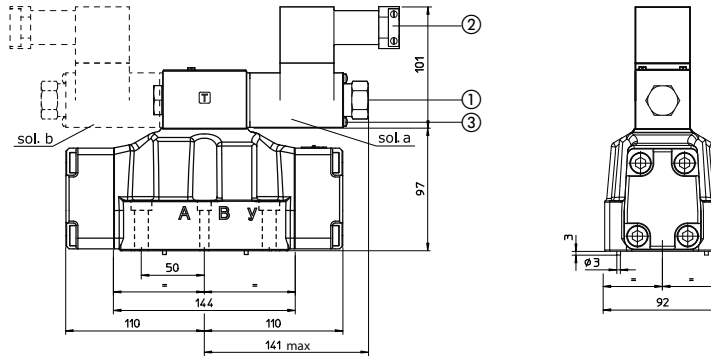

Mass of basic versions
 SDPHA/MA-26: 10,8 kg
 SDPHA/MA-27: 12,5 kg

- ① manual override
- ② horizontal cable gland, cable entrance = \varnothing 10,5 mm
- ③ screw terminal for additional equipotential grounding

SDPHA/MA-4

ISO 4401: 2005

Mounting surface: 4401-08-08-0-05 (see table P005)

Fastening bolts:
 6 socket head screws M12x60 class 12.9
 Tightening torque = 125 Nm
 Seals: 4 OR 4112; 2 OR 3056
 Diameter of ports A, B, P, T: $\varnothing = 24$ mm;
 Diameter of ports X, Y: $\varnothing = 7$ mm;

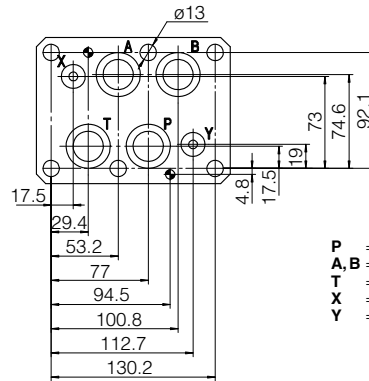

P = PRESSURE PORT
A, B = USE PORT
T = TANK PORT
X = EXTERNAL OIL PILOT PORT
Y = DRAIN PORT

SDPHA/MA-46

SDPHA/MA-47 (dotted line)

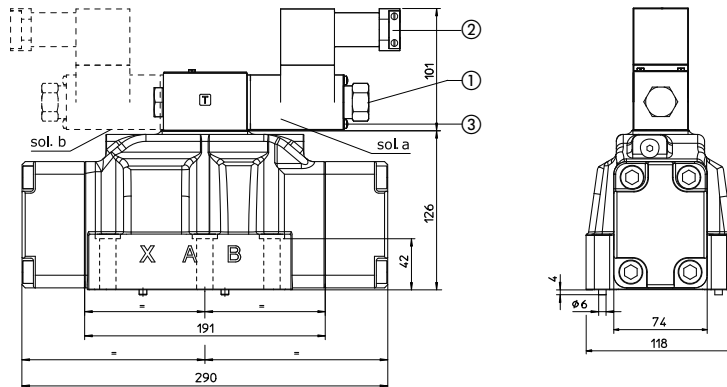

Mass of basic versions:
 SDPHA/MA-46: 19,4 kg
 SDPHA/MA-47: 21,9 kg

- ① manual override
- ② horizontal cable gland, cable entrance = \varnothing 10,5 mm
- ③ screw terminal for additional equipotential grounding

SAGAM/MA-10

ISO 6264: 2007

Mounting surface: 6264-06-09-1-97

Fastening bolts:

4 socket head screws M12x35 class 12.9

Tightening torque = 125 Nm

Seals: 2 OR 123; 1 OR 109/70

Ports P, T: $\varnothing = 14,5$ mm

Ports X: $\varnothing = 3,2$ mm

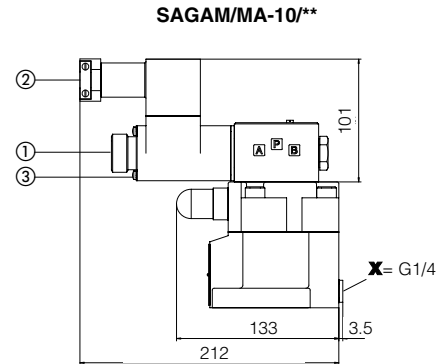
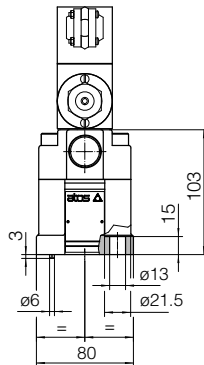
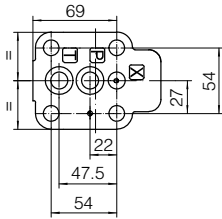

Mass: 5,1 Kg

SAGAM/MA-20

ISO 6264: 2007

Mounting surface: 6264-08-11-1-97

Fastening bolts:

4 socket head screws M16x50 class 12.9

Tightening torque = 300 Nm

Seals: 2 OR 4112; 1 OR 109/70

Ports P, T: $\varnothing = 24$ mm

Ports X: $\varnothing = 3,2$ mm

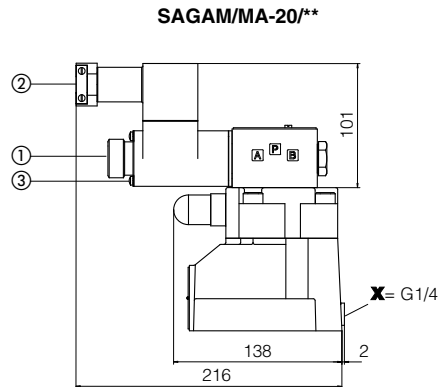
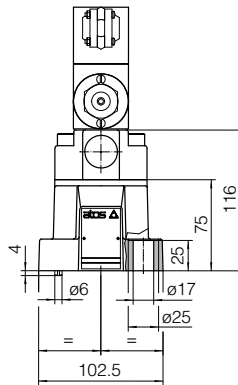
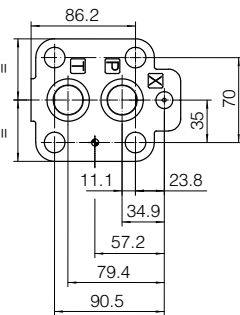

Mass: 6,3 Kg

SAGAM/MA-32

ISO 6264: 2007

Mounting surface: 6264-10-17-1-97

(with M20 fixing holes instead of standard M18)

Fastening bolts:

4 socket head screws M20x60 class 12.9

Tightening torque = 600 Nm

Seals: 2 OR 4131; 1 OR 109/70

Ports P, T: $\varnothing = 28,5$ mm

Ports X: $\varnothing = 3,2$ mm

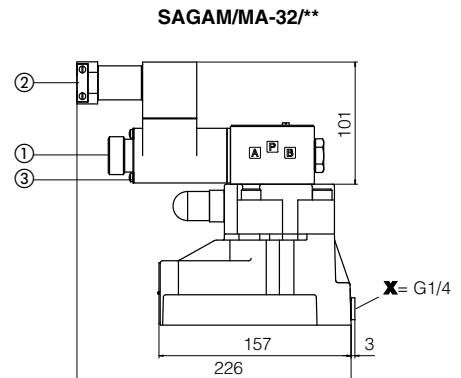
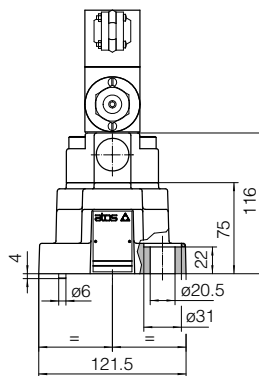
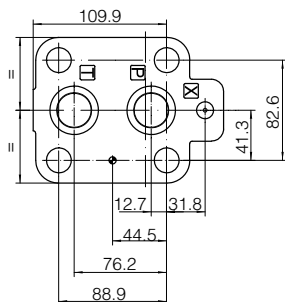

Mass: 7,7 Kg

- ① manual override
- ② horizontal cable gland, cable entrance = $\varnothing 10,5$ mm
- ③ screw terminal for additional equipotential grounding