

Ex-proof pressure relief valves

piloted, subplate - MA certification

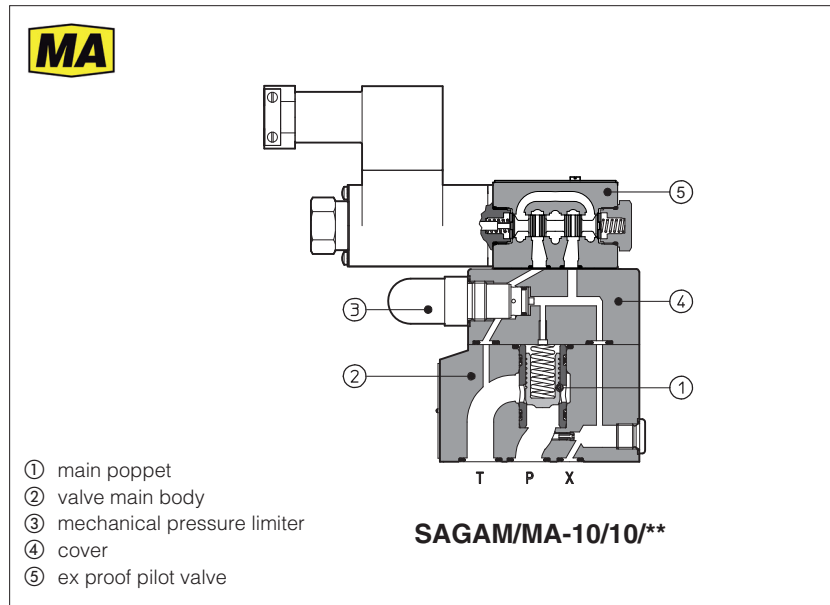

SAGAM/MA

Pressure relief valves equipped with explosion-proof solenoid pilot valve for venting certified according to **MA** Chinese mining certification, protection mode:

Ex db I Mb for surface, tunnel or mine plants

The solenoids are provided with cable glands (horizontally oriented) for cable entrance and internal terminal board for power supply coils connections.

The solenoid case classified **Ex db** is designed to contain the possible explosion which could be caused by the presence of the gas mixture inside the housing, thus avoiding dangerous propagation in the external environment.

They are also designed to limit the external temperature according to the certified class to avoid the self ignition of the explosive mixture present in the environment.

SAGAM: pressure relief, subplate mounting

Size: **10, 20, 32** - ISO 6264

Max flow: **200, 400, 600 l/min**

Max pressure: **350 bar**

1 MODEL CODE OF PRESSURE RELIEF VALVES TYPE SAGAM

SAGAM	/	MA	-	20	/	1		/	0	/	210	-	*	/	24DC		/	**	/	*
<p>SAGAM = pressure relief valve: subplate mounting</p>																		<p>Seals material, see section 6: - = NBR PE = FKM</p>		
<p>Certification type: MA = Ex-proof Ma Chinese mining certification</p>																		<p>Series number</p>		
<p>Valve size: 10 (ISO 6264) 20 (ISO 6264) 32 (ISO 6264)</p>																		<p>Voltage code, see section 5</p>		
<p>1 = one setting pressure</p>																		<p>Option: V = regulating handwheel for pressure adjustment</p>		
<p>Valve configuration, see section 2 0 = venting with de-energized solenoid 1 = venting with energized solenoid</p>																		<p>Max regulated pressure: 50 = 50 bar 210 = 210 bar 100 = 100 bar 350 = 210 bar</p>		

2 HYDRAULIC SYMBOL (representation according to ISO 1219-1)

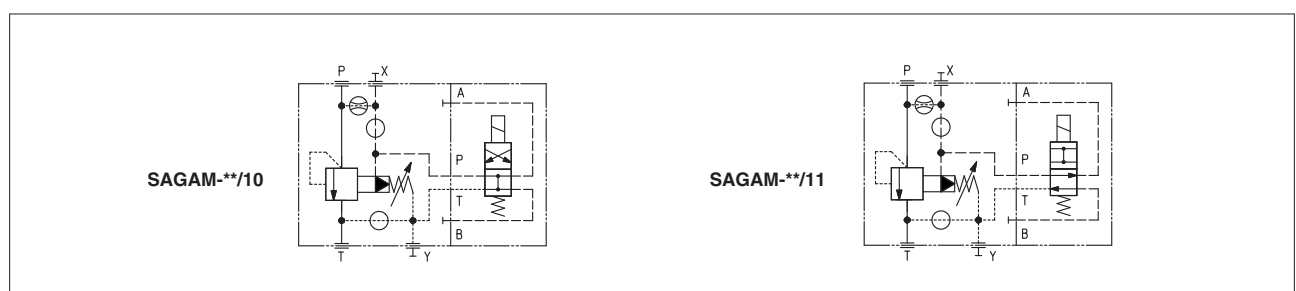

3 GENERAL CHARACTERISTICS

Assembly position / location	Any position
Subplate surface finishing to ISO 4401	Acceptable roughness index, Ra ≤0,8 recommended Ra 0,4 - flatness ratio 0,01/100
MTTFd values according to EN ISO 13849	75 years, for further details see technical table P007
Ambient temperature	Standard = -20°C ÷ +70°C /PE option = -20°C ÷ +70°C
Storage temperature range	Standard = -20°C ÷ +80°C /PE option = -20°C ÷ +80°C
Compliance	Explosion proof protection, see section 7 -Flame proof enclosure Ex-db

4 HYDRAULIC CHARACTERISTICS

Operating pressure	P, X = 350 bar T, Y = 210 bar
Maximum flow	SAGAM/MA-10 = 200 l/min; SAGAM/MA-20 = 400 l/min; SAGAM/MA-32 = 600 l/min;

5 ELECTRICAL CHARACTERISTICS

SOLENOID TYPE	ON/OFF
Voltage code VDC ±10%	12DC, 24DC, 110DC
Power consumption	16,5 W
Protection degree	IP 65 to DIN EN 60529
Duty factor	100%

6 SEALS AND HYDRAULIC FLUID

Seals, recommended fluid temperature	NBR seals (standard) = -20°C ÷ +60°C, with HFC hydraulic fluids = -20°C ÷ +50°C FKM seals (/PE option) = -20°C ÷ +80°C		
Recommended viscosity	15÷100 mm ² /s - max allowed range 2.8 ÷ 500 mm ² /s		
Max fluid contamination level	ISO4406 class 20/18/15 NAS1638 class 9, see also filter section at www.atos.com or KTF catalog		
Hydraulic fluid	Suitable seals type	Classification	Ref. Standard
Mineral oils	NBR, FKM, HNBR	HL, HLP, HLPD, HVL, HVLDP	DIN 51524
Flame resistant without water	FKM	HFDU, HFDR	ISO 12922
Flame resistant with water	NBR, HNBR	HFC	

7 CERTIFICATION DATA

Valve type	SAGAM/MA
Certification	MA mining
Solenoid certified code	DTBZ12 - 37 FYC
Type examination certificate	CNEx 22.7656X
Method of protection	Ex db I Mb
Ambient temperature	≤ 135 °C
Ambient temperature	-20 ÷ +40 °C
Cable entrance:	cable entrance Ø = 10.5mm

⚠ WARNING: service work performed on the valve by the end users or not qualified personnel invalidates the certification

8 SOLENOID WIRING

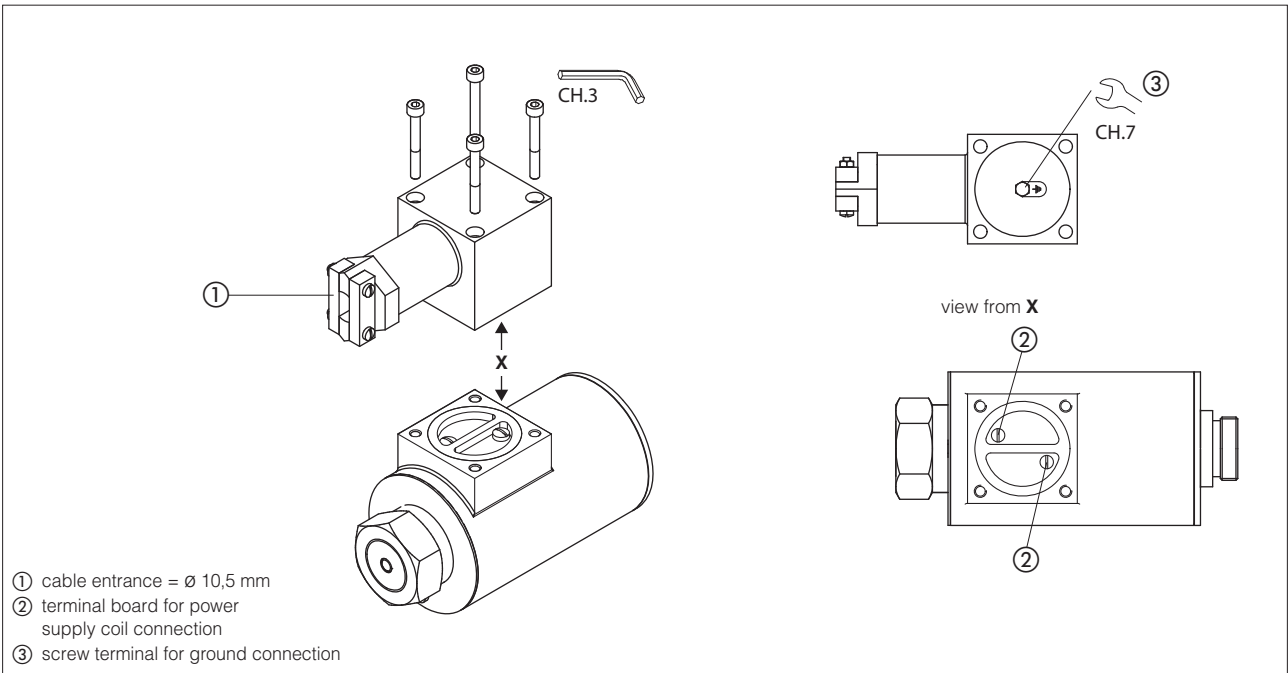

9 REGULATED PRESSURE VERSUS FLOW DIAGRAMS based on mineral oil ISO VG 46 at 50°C

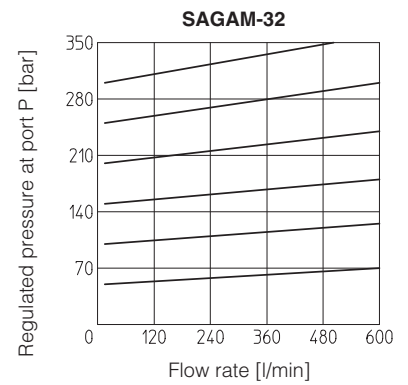
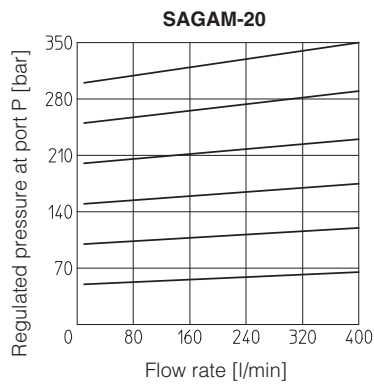
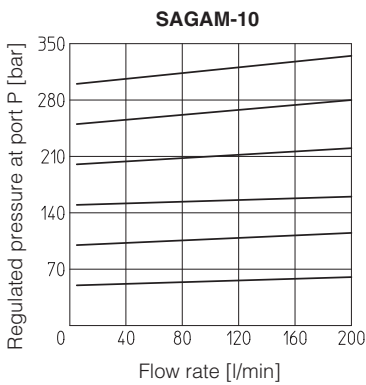

10 MINIMUM PRESSURE VERSUS FLOW DIAGRAMS based on mineral oil ISO VG 46 at 50°C

