

# Proportional reducing valves

direct, without transducer

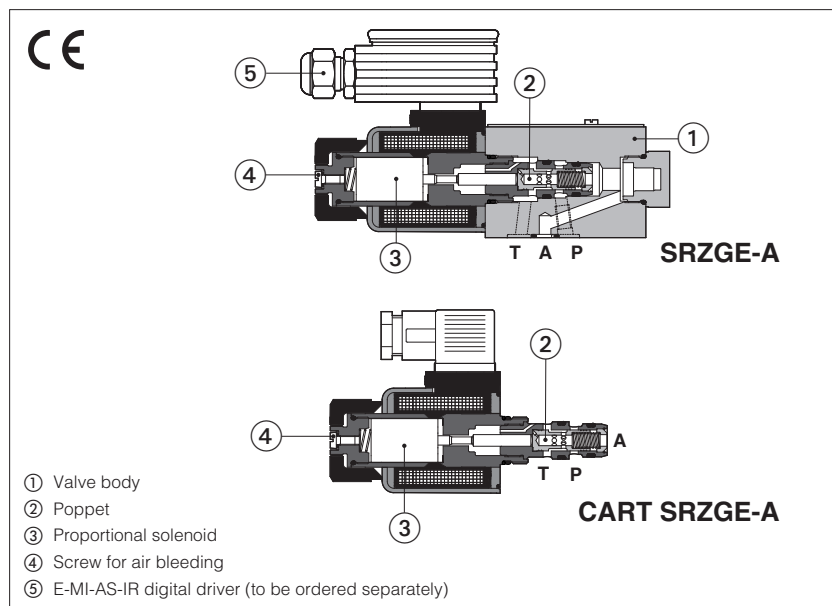

## SRZGE-A, CART SRZGE-A

Poppet type, direct, proportional pressure reducing valves for open loop pressure controls.

They operate in association with off-board driver, which supply the proportional valves with proper current to align the valve regulation to the reference signal supplied to the driver.

They are available in following executions:

**SRZGE:** subplate mounting, ISO 4401 size 06

**CART SRZGE:** M20 cartridge execution

Max flow: **12 l/min**

Max pressure: **350 bar**

For cavity dimensions see section [16](#)

## 1 MODEL CODE

<b>SRZGE</b>	-	<b>A</b>	-	<b>010</b>	/	<b>210</b>	-	*	/	*	/	*	/	*
<p>Proportional pressure reducing valve, direct</p> <p><b>SRZGE</b> = subplate mounting <b>CART SRZGE</b> = cartridge execution</p> <p><b>A</b> = for off-board driver, see section <a href="#">3</a></p> <p><b>Configuration:</b> <b>010</b> = reduced pressure on port A</p> <p><b>Max regulated pressure:</b> <b>32</b> = 32 bar <b>100</b> = 100 bar <b>210</b> = 210 bar</p>													<p><b>Seals material,</b> see section <a href="#">8</a> :</p> <ul style="list-style-type: none"> <li>- = NBR</li> <li><b>PE</b> = FKM</li> <li><b>BT</b> = HNBR</li> </ul> <p>Series number</p>	
<p><b>Coil voltage,</b> see section <a href="#">10</a> :</p> <ul style="list-style-type: none"> <li>- = standard coil for 24 Vdc Atos drivers</li> <li><b>6</b> = optional coil for 12 Vdc Atos drivers</li> <li><b>18</b> = optional coil for low current drivers <b>(1)</b></li> </ul>													<p><b>Coil with special connectors,</b> see section <a href="#">12</a> :</p> <ul style="list-style-type: none"> <li>- = omit for standard DIN connector</li> <li><b>J</b> = AMP Junior Timer connector</li> <li><b>K</b> = Deutsch connector</li> <li><b>S</b> = Lead Wire connection</li> </ul>	

**(1)** Select coil voltage **/18** in case of electronic drivers not supplied by Atos, with power supply 24 Vdc

## 2 HYDRAULIC SYMBOL

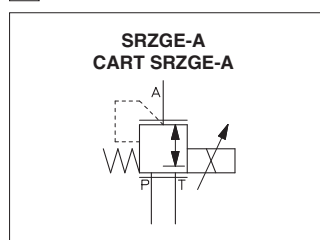

## 3 OFF-BOARD ELECTRONIC DRIVERS

Drivers model	E-MI-AC-01F <b>(1)</b>		E-MI-AS-IR <b>(1)</b>		E-BM-AS-PS		E-BM-AES
Type	Analog				Digital		
Voltage supply (Vdc)	12	24	12	24	12	24	24
Valve coil option	/6	std	/6	std	/6	std	std
Format	plug-in to solenoid				DIN-rail panel		
Tech table	G010		G020		G030		GS050

**(1)** For **CART RZGE** the electronic driver may interfere with the manifold surface. Please check the installation dimensions at section [16](#)

#### 4 GENERAL NOTES

Atos digital proportionals valves are CE marked according to the applicable directives (e.g. Immunity and Emission EMC Directive).

#### 5 GENERAL CHARACTERISTICS

Assembly position	Any position
Subplate surface finishing to ISO 4401	Acceptable roughness index: $R_a \leq 0,8$ , recommended $R_a 0,4$ – Flatness ratio 0,01/100
MTTFd valves according to EN ISO 13849	150 years, see technical table P007
Ambient temperature range	<b>Standard</b> = $-20^{\circ}\text{C} \div +70^{\circ}\text{C}$ <b>/PE</b> option = $-20^{\circ}\text{C} \div +70^{\circ}\text{C}$ <b>/BT</b> option = $-40^{\circ}\text{C} \div +60^{\circ}\text{C}$
Storage temperature range	<b>Standard</b> = $-20^{\circ}\text{C} \div +80^{\circ}\text{C}$ <b>/PE</b> option = $-20^{\circ}\text{C} \div +80^{\circ}\text{C}$ <b>/BT</b> option = $-40^{\circ}\text{C} \div +70^{\circ}\text{C}$
Surface protection	Zinc coating with black passivation
Corrosion resistance	Salt spray test (EN ISO 9227) > 200 h
Conformity	CE according to EMC directive 2014/30/EU (Immunity: EN 61000-6-2; Emission: EN 61000-6-3) RoHS Directive 2011/65/EU as last update by 2015/863/EU REACH Regulation (EC) n°1907/2006

#### 6 HYDRAULIC CHARACTERISTICS

Valve model	<b>SRZGE-A-010</b>	
Max regulated pressure	32; 100; 210	
Min. regulated pressure [bar]	0,8 (or actual value at T port)	
Max. pressure at port P [bar]	350	
Max. pressure at port T [bar]	210	
Max. flow [l/min]	12	
Response time 0-100% step signal <b>(1)</b> [ms] (depending on installation)	$\leq 70$	
Hysteresis [% of the max pressure]	$\leq 1,5$	
Linearity [% of the max pressure]	$\leq 3$	
Repeatability [% of the max pressure]	$\leq 2$	

**Note:** above performance data refer to valves coupled with Atos electronic drivers, see section 3

**(1)** Average response time values; the pressure variation in consequence of a modification of the reference input signal to the valve is affected by the stiffness of the hydraulic circuit: greater is the stiffness of the circuit, faster is the dynamic response

#### 7 ELECTRICAL CHARACTERISTICS

	<b>Standard</b> standard coil to be used with Atos drivers with power supply 24V <sub>DC</sub>	option <b>/6</b> optional coil to be used with Atos drivers with power supply 12 V <sub>DC</sub>	option <b>/18</b> optional coil to be used with electronic drivers not supplied by Atos, with power supply 24 V <sub>DC</sub>
Coil voltage code			
Coil resistance R at 20°C	3,1 Ω	2,1 Ω	13,1 Ω
Max. solenoid current	2,5 A	3 A	1,2 A
Insulation class	H (180°) Due to the occurring surface temperatures of the solenoid coils, the European standards ISO 13732-1 and EN982 must be taken into account		
Protection degree to DIN EN60529	<b>IP 65</b> (with connectors 666 correctly assembled)		
Duty factor	Continuous rating (ED=100%)		

#### 8 SEALS AND HYDRAULIC FLUIDS - for other fluids not included in below table, consult our technical office

Seals, recommended fluid temperature	NBR seals (standard) = $-20^{\circ}\text{C} \div +80^{\circ}\text{C}$ , with HFC hydraulic fluids = $-20^{\circ}\text{C} \div +50^{\circ}\text{C}$ FKM seals (/PE option) = $-20^{\circ}\text{C} \div +80^{\circ}\text{C}$ HNBR seals (/BT option) = $-40^{\circ}\text{C} \div +60^{\circ}\text{C}$ , with HFC hydraulic fluids = $-40^{\circ}\text{C} \div +50^{\circ}\text{C}$		
Recommended viscosity	20 ÷ 100 mm <sup>2</sup> /s - max allowed range 15 ÷ 380 mm <sup>2</sup> /s		
Max fluid contamination level	normal operation	ISO4406 class 18/16/13 NAS1638 class 7	see also filter section at <a href="http://www.atos.com">www.atos.com</a> or KTF catalog
	longer life	ISO4406 class 16/14/11 NAS1638 class 5	
<b>Hydraulic fluid</b>	<b>Suitable seals type</b>	<b>Classification</b>	<b>Ref. Standard</b>
Mineral oils	NBR, FKM, HNBR	HL, HLP, HLPD, HVLP, HVLPD	DIN 51524
Flame resistant without water	FKM	HFDR, HFDR	ISO 12922
Flame resistant with water	NBR, HNBR	HFC	

**9 DIAGRAMS** (based on mineral oil ISO VG 46 at 50 °C)

**1 = Regulation diagrams**  
with flow rate  $Q = 1$  l/min

**Note:** the presence of counter pressure at port T can affect the effective pressure regulation

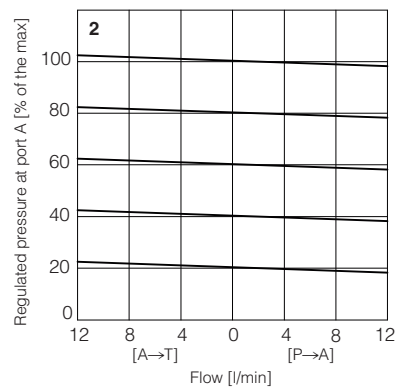
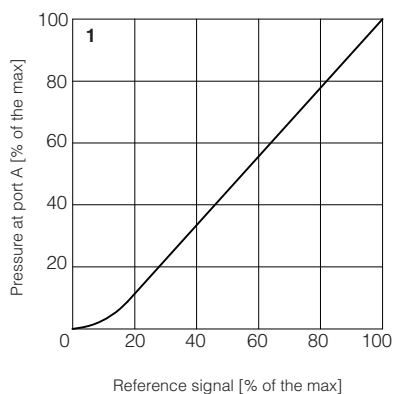

**2 = Pressure/flow diagrams**  
with reference signal set at  $Q = 1$  l/min

**3-4 = Min. pressure/flow diagrams**  
with zero reference signal

**3 =** Pressure drops vs. flow P-A  
**4 =** Pressure drops vs. flow A-T

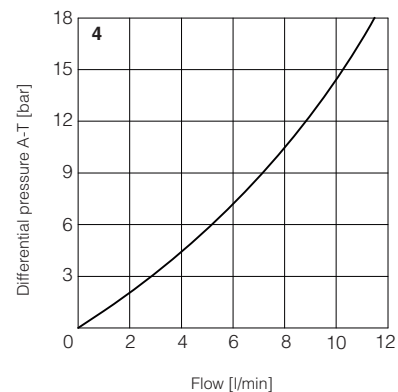
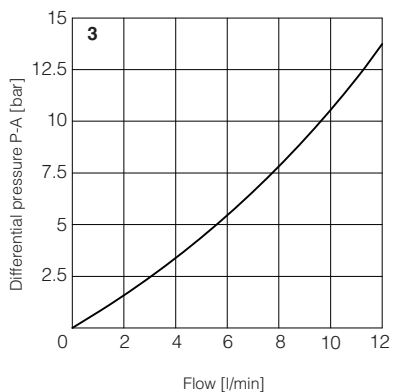

**10 COIL VOLTAGE OPTIONS**

- 6 =** Optional coil to be used with Atos drivers with power supply 12 VDC.
- 18 =** Optional coil to be used with electronic drivers not supplied by Atos, with power supply 24 VDC.

**11 AIR BLEEDING**

At the first valve commissioning the air eventually trapped inside the solenoid must be bled-off through the screw ① located at the rear side of the solenoid housing.  
The presence of air may cause pressure instability and vibrations.

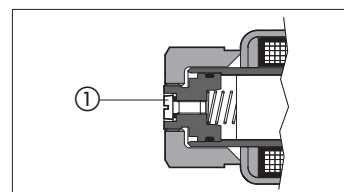

**12 COILS WITH SPECIAL CONNECTORS**

**J option**

Coil type COZEJ  
AMP Junior Timer connector  
Protection degree IP67

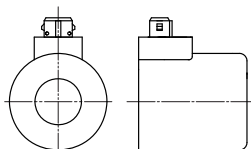

**K option**

Coil type COZEK  
Deutsch connector, DT-04-2P male  
Protection degree IP67

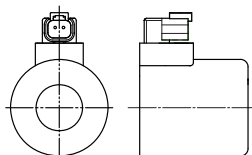

**S option**

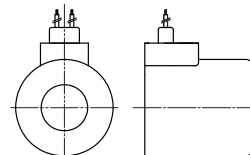

Coil type COZES  
Lead Wire connection  
Cable length = 180 mm



**13 SOLENOID CONNECTION**

PIN	SIGNAL	TECHNICAL SPECIFICATION	Connector code 666 
1	COIL	Power supply	
2	COIL	Power supply	
3	GND	Ground	

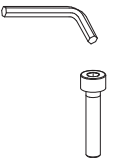
**14 FASTENING BOLTS AND SEALS FOR SRZGE**

	<p><b>Fastening bolts:</b> 4 socket head screws M5x50 class 12.9 Tightening torque = 8 Nm</p>
	<p><b>Seals:</b> 3 OR 108 Diameter of ports P, T, A: <math>\varnothing 5</math> mm Port B not used</p>

**15 INSTALLATION DIMENSIONS FOR SRZGE [mm]**

ISO 4401: 2005  
Mounting surface: 4401-03-02-0-05  
(without port B)

Mass [kg]	
SRZGE	1,5
SRZGE with E-MI-AS-IR	2,0

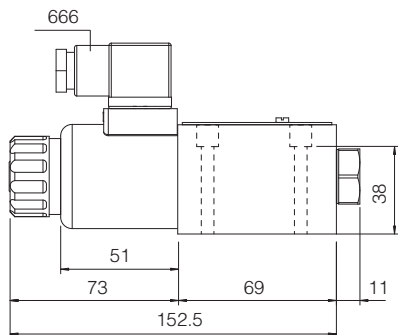
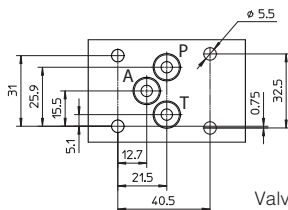

**SRZGE-A**

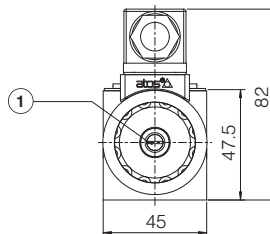

**SRZGE-A**  
(with E-MI-AS-IRdigital driver)

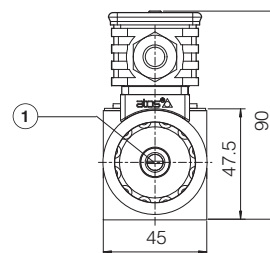
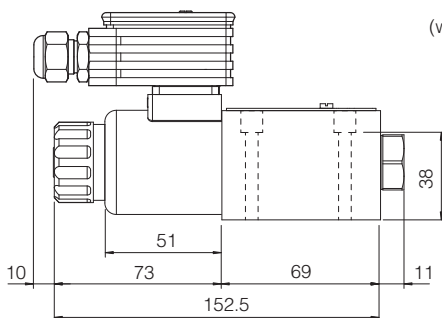

① = Air bleeding, see section 11 

16 INSTALLATION DIMENSIONS FOR CART SRZGE [mm]

Cavity dimensions for **CART SRZGE-A**

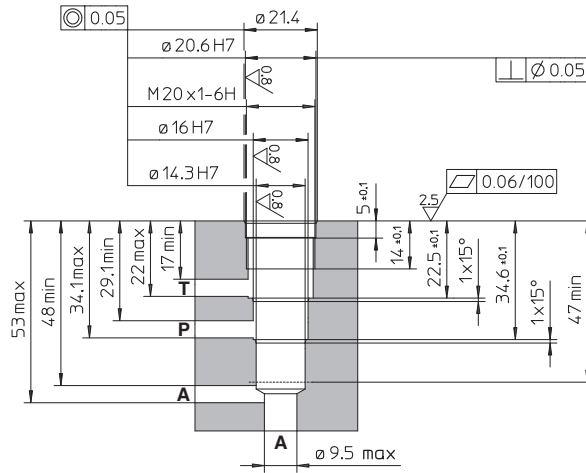

**CART SRZGE-A**

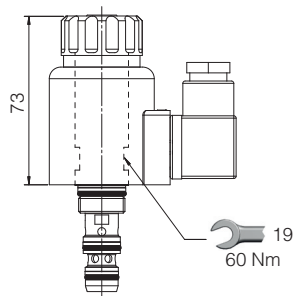

**CART SRZGE-A**  
(with E-MI-AS-IR digital driver)

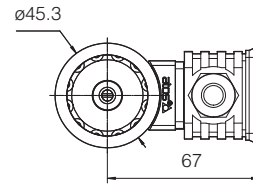
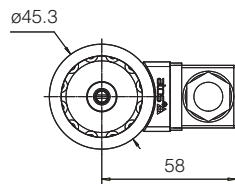
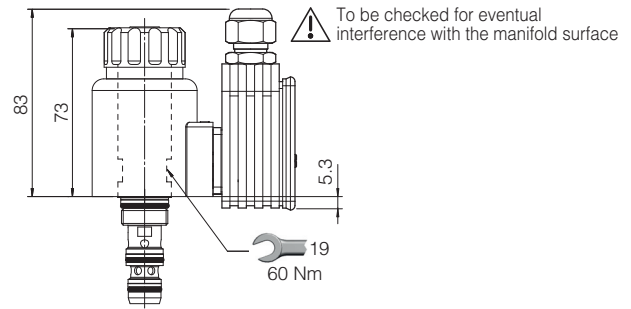

Mass [kg]	
CART SRZGE	0,6
CART SRZGE with E-MI-AS-IR	1,1