

Proportional directional valves type DPZO-AES

two stage without position transducer, ISO 4401 sizes 10, 16, 25 and 32

**AES execution included in this table is available only for running supplies or spare parts
For new applications it is suggested new AEB and AES executions, see table FS170**

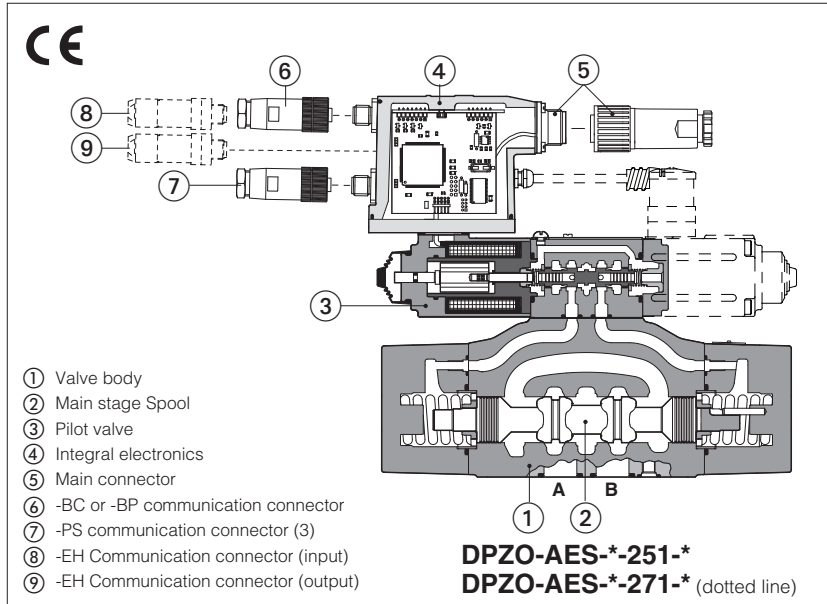

1 MODEL CODE

DPZO - AES- PS - 2 7 1 - D 5 / * * * /*										
Piloted proportional directional valve									Seals material, see section 4: - = NBR PE = FKM BT = HNBR (only -A) Series number	
A = without position transducer AE = as A plus integral electronics AES = as A plus integral digital electronics									Coil voltage (only for -A execution) see section 8: - = standard coil for 24V _{dc} Atos drivers 6 = optional coil for 12V _{dc} Atos drivers 18 = optional coil for low current drivers	
Communication interfaces only for AES (1) PS = USB BC = CANopen BP = PROFIBUS DP EH = EtherCAT									Hydraulic options, see sect. 8: B = solenoid and integral electronics at side of port B of the main stage (side A of pilot valve); D = internal drain E = external pilot G = pressure reducing valve for piloting	
Valve size: 1 = 10 2 = 16 4 = 25 6 = 32									Electronics options for -AE execution, see section 11: I = current reference input (4±20 mA) Q = enable signal	
Configuration, see section 3: 5 = external plus central position, spring centered 7 = 3 positions; spring centered									Electronics options for -AES execution, see section 12: Q = enable signal Z = double power supply, enable fault and monitor (12 pin connector) W = power limitation function (12 pin connector) see sect. 11.3	
Spool overlapping in central position, see sect. 3: 1 = P, A, B, T positive overlapping (2) 3 = P positive overlapping A, B, T negative overlapping									Notes: (1) USB interface always present, also for -BC and -BP and -EH options (2) Overlapping = 20% of spool stroke for type S and D , 10% of spool stroke for type L	
Spool type L = linear S = progressive D = as S , but with P-A = Q, P-B = Q/2										
Spool size: 3 and 5 , see section 3										

DPZO-A* are two stage proportional valves without position transducer, which provide both directional and non compensated flow control according to the electronic reference signal.

They operate in association with electronic drivers, see section 2, which supply the proportional valves with correct current signal to align valve regulation to the reference signal supplied to the electronic driver.

They are available in different executions:

- -A, without position transducer;
- -AE, -AES as -A plus analogue (AE) or digital (AES) integral electronics 4;

The 4-way spool 2, sliding into a 5-chambers body 1, is piloted in open loop by the proportional pressure reducing valve 3 type DHRZO.

The integral electronics 4 ensures factory presetting, fine functionality plus valve-to-valve interchangeability and simplified wiring and installation.

The electronic main connector 5 is fully interchangeable for -AE and -AES executions.

Standard 7 pin main connector is used for power supply, analog input reference and monitor signals.

12 pin connector is used for options /Z, /W (AES).

Following communication interfaces 6, 7 are available for the digital -AES execution:

- standard -PS, Serial communication interface for configuration, monitoring and firmware updating through Atos PC software - always present, also for -BC, -BP and -EH options
- optional -BC, CANopen interface
- optional -BP, PROFIBUS DP interface
- -EH, EtherCAT interface

The valves with -BC, -BP and -EH interfaces can be integrated into a fieldbus communication network and thus digitally operated by the machine control unit.

Surface mounting: **ISO 4401**
Size **10, 16, 25 and 32**.

Max flow respectively up to:
160 l/min, 430 l/min, 720 l/min and 1000 l/min with valve differential pressure $\Delta p = 30$ bar, see section 3.

Max pressure: **350 bar**

2 ELECTRONIC DRIVERS FOR DPZO-A*

Valve model	-A					-AE	-AES
Drivers model	E-MI-AC-0*F	E-MI-AS-IR	E-BM-AC-0*F	E-BM-AS-PS	E-ME-AC-0*F	E-RP-AC-0*F	E-RI-AES
Data sheet	G010	G020	G025	G030	G035	G100	G115

Note: for main and communication connector see section 14

3 HYDRAULIC CHARACTERISTICS (based on mineral oil ISO VG 46 at 50 °C)

Valve model	DPZO-1			DPZO-2					DPZO-4			DPZO-6		
Spool overlapping	1, 3													
Spool type and size	L5	S5	D5	S3	D3	L5	S5	D5	L5	S5	D5	L5	S5	D5
Max flow (1) [l/min]														
at $\Delta p = 10$ bar (P-T)	100	100	100:60	160	160:98	250	225	225:160	420	400	400:245	600	600	600:370
at $\Delta p = 30$ bar (P-T)	160	160	160:100	270	270:160	430	390	390:280	720	690	690:420	1000	1000	1000:620
max permissible flow	180	180	180:110	400	400:245	550	550	550:390	900	900	900:550	1600	1600	1600:990
Pressure limits (2) [bar]	ports P, A, B, X = 350; T = 250 (5 for option /D); Y = 5													
Response time [ms] (3)	< 80			< 100					< 120			< 180		
Hysteresis [%]	≤ 5%													
Repeatability	± 1%													

Notes:

- For version DPZO-A and DPZO-AE, configuration /B, see the notes at section 6.1
- Above performance data refer to valves coupled with Atos electronic drivers, see section 2.
- In case of long time shutdown of the hydraulic supply to the pilot valve, the driver has to be switched off to avoid its overheating.
- The flow regulated by the directional proportional valves is not pressure compensated, thus it is affected by the load variations. To keep constant the regulated flow under different load conditions, modular pressure compensators are available (see tab. D150).

- (1) For different Δp , the max flow is in accordance to the diagrams in section 13.2
- (2) Minimum piloting pressure = 30 bar
- (3) 0-100% step signal

FUNCTIONAL SCHEME

example of configuration 7
(3 positions, spring centered)

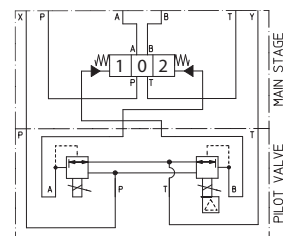

4 MAIN CHARACTERISTICS

Assembly position	Any position		
Subplate surface finishing	Roughness index, Ra 0,4 flatness ratio 0,01/100 (ISO 1101)		
MTTFd valves according to EN ISO 13849	75 years, for further details, see technical table P007		
Ambient temperature	-A execution = -20°C ÷ +70°C (storage -20°C ÷ +80°C) /BT option -40°C ÷ +60°C (storage -40°C ÷ +70°C) -AE execution = -20°C ÷ +60°C (storage -20°C ÷ +70°C) -AES execution = -20°C ÷ +60°C (storage -20°C ÷ +70°C)		
Fluid	Hydraulic mineral oil HL, HLP as per DIN 51524		
Recommended viscosity	20 ÷ 100 mm ² /s - max allowed range 15 ÷ 380 mm ² /s		
Fluid contamination class	ISO 4406 class 20/18/15 NAS 1638 class 9, in line filters of 10 μm (β ₁₀ ≥ 75 recommended)		
Fluid temperature	-20°C +60°C (standard seals) -20°C +80°C (/PE option) -40°C +60°C (/BT option)		
Coil code	Standard	Option /6	Option /18
Coil resistance R at 20°C	3 ÷ 3,3 Ω	2 ÷ 2,2 Ω	13 ÷ 13,4 Ω
Max. solenoid current	1,9 A	2,35 A	0,9 A
Max. power	-A execution = 35 Watt -AE and -AES executions = 50 Watt		
Insulation class	H (180°) Due to the occurring surface temperatures of the solenoid coils, the European standards ISO 13732-1 and EN982 must be taken into account		
Protection degree to DIN EN60529	-A execution = IP65 -AE, and -AES executions = IP67		
Duty factor	Continuous rating (ED=100%)		

5 GENERAL NOTES

DPZO-A* proportional valves are CE marked according to the applicable Directives (e.g. Immunity/Emission EMC Directive and Low Voltage Directive). Installation, wirings and start-up procedures must be performed according to the general prescriptions shown in table F003 and in the installation notes supplied with relevant components.

The electrical signals of the valve (e.g. monitor signals) must not be directly used to activate safety functions, like to switch-ON/OFF the machine's safety components, as prescribed by the European standards (Safety requirements of fluid technology systems and components-hydraulics, EN-982).

6 HYDRAULIC OPTIONS

- 6.1 Option /B** DPZO-*5 = solenoid and integral electronics at side of port B of the main stage.
DPZO-*7 = integral electronics at side of port B of the main stage.
For hydraulic configuration vs. reference signal, see section 13.1

6.2 Pilot and drain configuration -The pilot / drain configuration can be modified as shown in the table E085 section 12.

The valve's standard configuration provides internal pilot and external drain. For different pilot / drain configuration select:

Option /E External pilot (through port X).

Option /D Internal drain.

Option /G Pressure reducing valve with fixed setting (= 40 bar for DPZO-1 and -2; 100 bar for DPZO-4 and -6) installed between pilot valve and main body.
It is advisable for valves with internal pilot in case of system pressure higher than 200 bar.

7 CONNECTIONS FOR -A EXECUTION

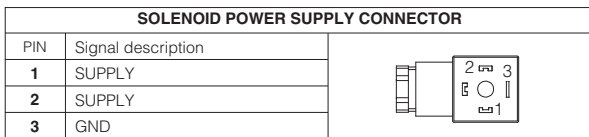

8 OPTIONS FOR -A EXECUTION

- Option /6** optional coil to be used with Atos drivers with power supply 12 Vdc
Option /18 optional coil to be used with electronic drivers not supplied by Atos

9 ANALOG INTEGRAL DRIVER -AE -ELECTRONIC CONNECTIONS AND SETTINGS

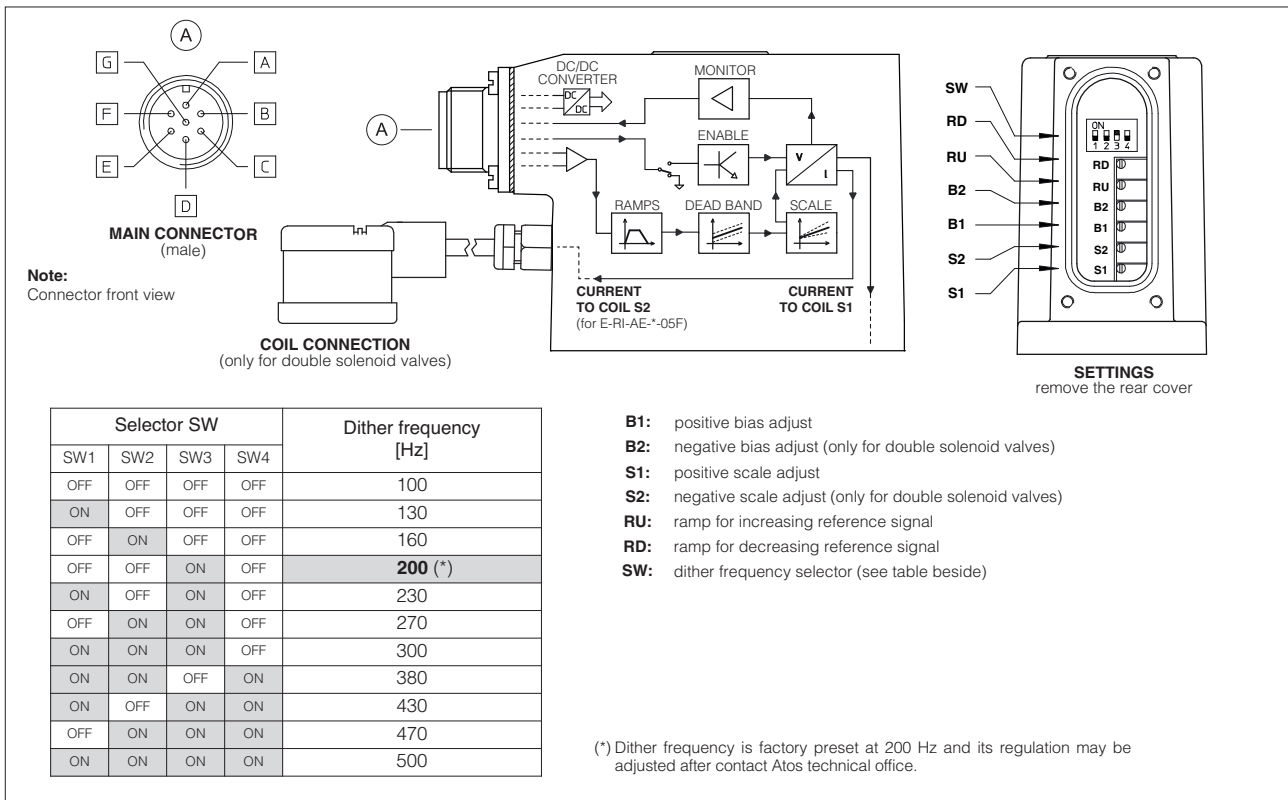

9.1 MAIN CONNECTOR - 7 pin (A)

PIN	SIGNAL	TECHNICAL SPECIFICATIONS	NOTES
A	V+	Power supply 24 Vdc for solenoid power stage and driver logic	Input - power supply
B	V0	Power supply 0 Vdc for solenoid power stage and driver logic	Gnd - power supply
C	AGND	Ground - signal zero for MONITOR signal	Gnd - analog signal
	ENABLE	Enable (24 Vdc) or disable (0 Vdc) the driver (for /Q option) With /Q option:ENABLE signal replaces AGND on pin C; MONITOR signal is referred to pin B	Input - on/off signal
D	INPUT+	Reference analog differential input: ± 10 Vdc maximum range (4 \div 20 mA for /I option) For single solenoid valves the reference input is 0 \div 10 Vdc (4 \div 20 mA for /I option)	Input - analog signal
E	INPUT -	For double solenoid valves the reference input is ± 10 Vdc (4 \div 20 mA for /I option)	
F	MONITOR	Monitor analog output: ± 5 Vdc maximum range (1V monitor = 1A coil current) For single solenoid valves: 0 \div 5 Vdc referred to pin C (for /I option) 0 \div 5 Vdc referred to pin B (for /Q option) For double solenoid valves: ± 5 Vdc referred to pin C (for /I option) ± 5 Vdc referred to pin B (for /Q option)	Output - analog signal
G	EARTH	Internally connected to the driver housing	

- A minimum time of 60ms to 160ms have be considered between the driver energizing with the 24 Vdc power supply and when the valve is ready to operate. During this time the current to the valve coils is switched to zero

10 ANALOG INTEGRAL DRIVERS -AE - OPTIONS

Standard driver execution provides on the 7 pin main connector:

- Power supply** - 24Vdc must be appropriately stabilized or rectified and filtered; a 2,5 A safety fuse is required in series to the driver power supply.
Apply at least a 10000 μ F/40 V capacitance to single phase rectifiers or a 4700 μ F/40 V capacitance to three phase rectifiers
- Reference input signal** - analog differential input with ± 10 Vdc nominal range (pin D, E), proportional to desired coil current.
- Monitor output signal** - analog output signal proportional to the actual valve's coil current (1V monitor = 1A coil current)

Following options are available to adapt standard execution to special application requirements:

10.1 Option /I

It provides the 4 \div 20 mA current reference signal instead of the standard ± 10 Vdc. Monitor output signal is still the standard ± 10 Vdc.

It is normally used in case of long distance between the machine control unit and the valve or where the reference signal can be affected by electrical noise; the valve functioning is disabled in case of reference signal cable breakage.

10.2 Option /Q

It provides the possibility to enable or disable the valve functioning without cutting the power supply (the valve functioning is disabled but the driver current output stage is still active). To enable the driver supply a 24Vdc on the enable input signal.

10.3 Possible combined options: /IQ

11 CONNECTIONS

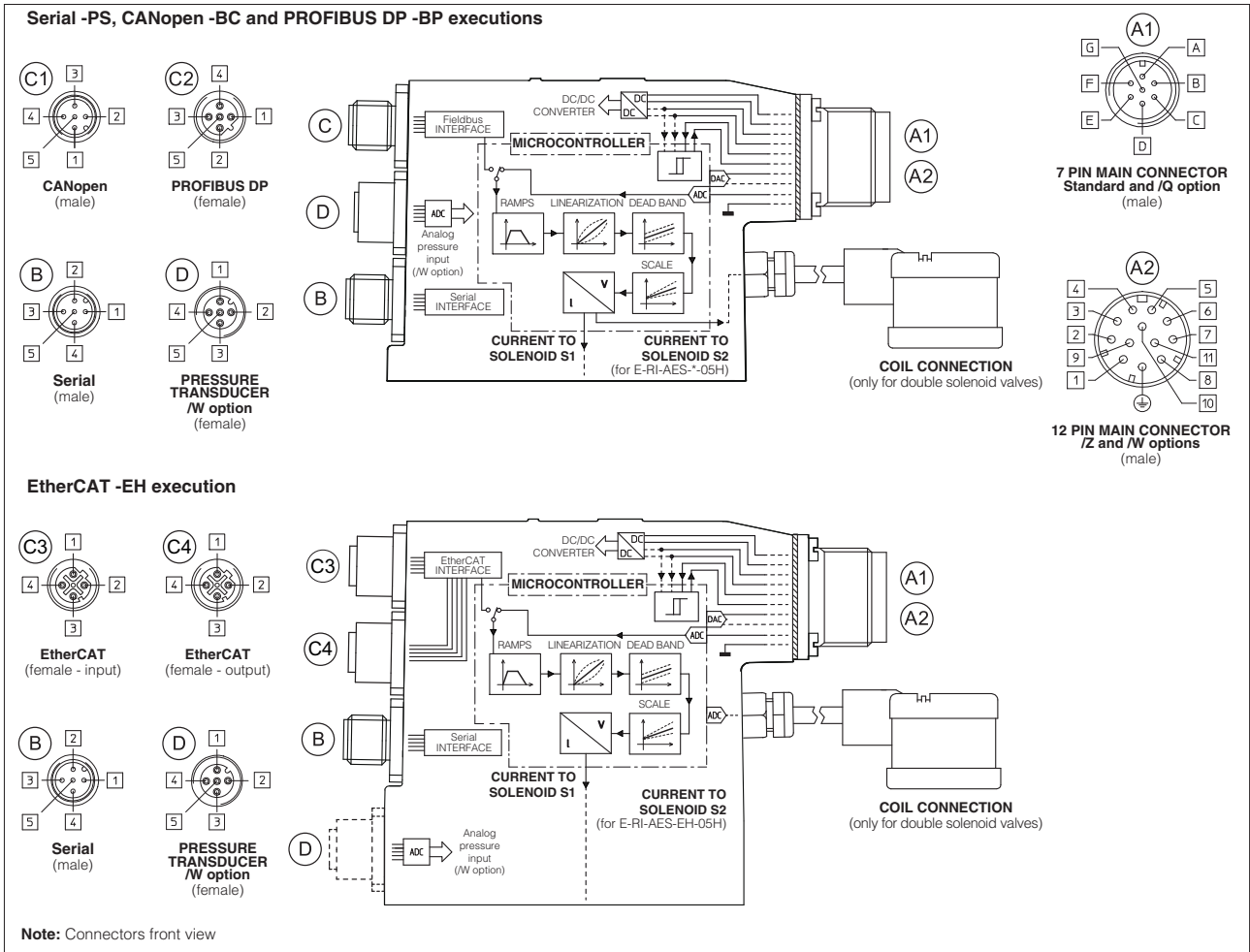

11.1 Main connector - 7 pin - Standard and /Q option (A1)

PIN	SIGNAL	TECHNICAL SPECIFICATIONS	NOTES
A	V+	Power supply 24 Vdc for solenoid power stage	Input - power supply
B	V0	Power supply 0 Vdc for solenoid power stage	Gnd - power supply
C	AGND	Ground - signal zero for MONITOR signal (applying 24 Vdc to AGND electronics will be damaged)	Gnd - analog signal
	ENABLE	Enable (24 Vdc) or disable (0 Vdc) the driver (for /Q option)	Input - on/off signal
D	INPUT+	Reference analog differential input: ± 10 Vdc / ± 20 mA maximum range software selectable (see 4.2) - default settings are 0 ÷ 10 Vdc for directional valves 2 positions, pressure or flow controls and ± 10 Vdc for directional valves 3 positions	Input - analog signal
E	INPUT -		
F	MONITOR	Monitor analog output: ± 5 Vdc maximum range	Output - analog signal
G	EARTH	Internally connected to driver housing	

11.2 Main connector - 12 pin - /Z and /W options (A2)

PIN	SIGNAL	TECHNICAL SPECIFICATIONS	NOTES
1	V+	Power supply 24 Vdc for solenoid power stage	Input - power supply
2	V0	Power supply 0 Vdc for solenoid power stage	Gnd - power supply
3	ENABLE	Enable (24 Vdc) or disable (0 Vdc) the driver	Input - on/off signal
4	INPUT+	Reference analog input: ± 10 Vdc / ± 20 mA maximum range software selectable	Input - analog signal
5	AGND	Ground - signal zero for INPUT+ signal	Gnd - analog signal
6	MONITOR	Monitor analog output: ± 5 Vdc maximum range	Output - analog signal
7	NC	do not connect	
8	NC	do not connect (for /Z option)	
	MONITOR2	2nd monitor analog output: ± 5 Vdc maximum range (for /W option)	Output - analog signal
9	VL+	Power supply 24 Vdc for driver's logic and communication	Input - power supply
10	VLO	Power supply 0 Vdc for driver's logic and communication	Gnd - power supply
11	FAULT	Driver status : Fault (0 Vdc) or normal working (24 Vdc)	Output - on/off signal
PE	EARTH	Internally connected to driver housing	

Note: A minimum time of 270 to 340 ms have to be considered between the driver energizing with the 24 VDC power supply and when the valve is ready to operate. During this time the current to the valve coils is switched to zero.

11.3 COMMUNICATION CONNECTORS (B) (C)

(B) -PS serial execution - M12 - 5 pin (1)		
PIN	SIGNAL	TECHNICAL SPECIFICATION (2)
1	NC	do not connect
2	NC	do not connect
3	RS_GND	Signal zero data line
4	RS_RX	Valves receiving data line
5	RS_TX	Valves transmitting data line

(C1) -BC fieldbus execution - M12 - 5 pin		
PIN	SIGNAL	TECHNICAL SPECIFICATION (2)
1	CAN_SHLD	Shield
2	NC	do not connect
3	CAN_GND	Signal zero data line
4	CAN_H	Bus line (high)
5	CAN_L	Bus line (low)

(C2) -BP fieldbus execution - M12 - 5 pin		
PIN	SIGNAL	TECHNICAL SPECIFICATION (2)
1	+5V	Termination supply signal
2	LINE-A	Bus line (high)
3	DGND	Data line and termination signal zero
4	LINE-B	Bus line (low)
5	SHIELD	

(C3) (C4) -EH fieldbus execution - M12 - 4 pin		
PIN	SIGNAL	TECHNICAL SPECIFICATION (2)
1	TX+	Transmitter
2	RX+	Receiver
3	TX-	Transmitter
4	RX-	Receiver
Housing	SHIELD	

Note: (1) USB communication not insulated
(2) Shield connection on connector's housing is recommended

11.4 PRESSURE TRANSDUCER CONNECTOR - M12 - 5 pin (only for /W option) (D)

Voltage Input (*)			Current Input (*)	
PIN	SIGNAL	TECHNICAL SPECIFICATION	SIGNAL	TECHNICAL SPECIFICATION
1	VT	Remote transducer power supply 24 Vdc	VT	Remote transducer power supply 24 Vdc
2	TR	Remote transducer signal (0 ÷ 10 Vdc) - see 4.7	TR	Remote transducer signal (0 ÷ 20 mA) - see 4.7
3	AGND	Signal zero for power supply and signal	NC	do not connect
4	NC	do not connect	NC	do not connect
5	NC	do not connect	NC	do not connect

(*) **Note:** Analog input range is software selectable

12 DIGITAL INTEGRAL DRIVERS -AES - OPTIONS

Standard driver execution provides on the 7 pin main connector:

Power supply - 24Vdc must be appropriately stabilized or rectified and filtered; a 2,5 A safety fuse is required in series to each driver power supply. Apply at least a 10000 µF/40 V capacitance to single phase rectifiers or a 4700 µF/40 V capacitance to three phase rectifiers.

Reference input signal - analog differential input with ±10Vdc nominal range (pin D,E), proportional to desired coil current (4÷20 mA with cable break detection, ±10 mA, ±20 mA or 0÷20 mA software selectable)

Monitor output signal - analog output signal proportional to the actual valve's coil current (1V monitor = 1A coil current)

Following options are available to adapt standard execution to special application requirements:

12.1 Option /Q - To enable the driver, supply 24Vdc on pin C referred to pin B: when the enable signal is set to zero the valve status is software selectable, by factory default the valve functioning is disabled (zero current to the solenoid) but the driver current output stage is still active. For the complete list of selectable status, see tab. G115.

12.2 Option /Z - It provides, on the 12 pin main connector, the following additional features:

Logic power supply

Separated power supply for the solenoid (pin 1, 2) and for the digital electronic circuits (pin 9, 10).

Cutting solenoid power supply allows to interrupt the valve functioning but keeping energized the digital electronics thus avoiding fault conditions of the machine fieldbus controller. This condition allows to realize safety systems in compliance with European Norms EN13849-1 (ex EN954-1).

Enable Input Signal

To enable the driver, supply 24Vdc on pin 3 referred to pin 2: when the enable signal is set to zero the valve status is software selectable, by factory default the valve functioning is disabled (zero current to the solenoid) but the driver current output stage is still active. For the complete list of selectable status, see tab. G115.

Fault Output Signal

Fault output signal indicates fault conditions of the driver (solenoid short circuits/not connected, reference signal cable broken for 4÷20mA input, etc.). Fault presence corresponds to 0 Vdc, normal working corresponds to 24Vdc (pin 11 referred to pin 2): Fault status is not affected by the Enable input signal

12.3 Option /W - only for valves coupled with pressure compensator type HC-011 or KC-011 (see tab. D150).

It provides, on the 12 pin main connector, the above option /Z features plus the hydraulic power limitation function.

The driver receives the flow reference signal by the analog external input INPUT+ and a pressure transducer remotely installed in the hydraulic system, has to be connected to the driver's analog input TR.

When the actual requested hydraulic power $p \times Q$ (TR x INPUT+) reaches the max power limit ($p1 \times Q1$), internally set by software, the driver automatically reduces the flow regulation of the valve. The higher is the pressure feedback the lower is the valve's regulated flow:

$$\text{Flow regulation} = \text{Min} \left(\frac{\text{PowerLimit [sw setting]}}{\text{Transducer Pressure [TR]}}; \text{Flow Reference [INPUT+]} \right)$$

For detailed information on hydraulic power limitation, see tab. G115

13 **DIAGRAMS** (based on mineral oil ISO VG 46 at 50 °C)

13.1 Regulation diagrams

- DPZO-1:
1 = linear spool L5
2 = differential spool S5, D5
- DPZO-2:
3 = progressive spool S3, D3
4 = progressive spool S5, D5
5 = linear spool L5
- DPZO-3:
6 = linear spool L5
7 = progressive spool S5, D5
- DPZO-4:
8 = linear spool L5
9 = progressive spool S5, D5
- DPZO-6:
10 = linear spool L5
11 = progressive spool S5, D5

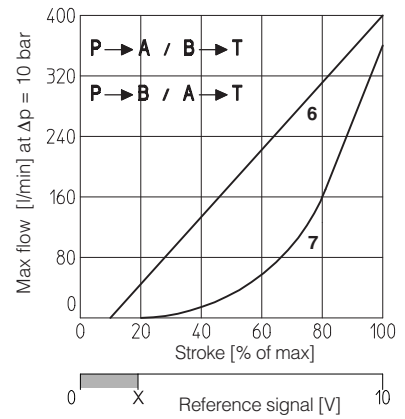
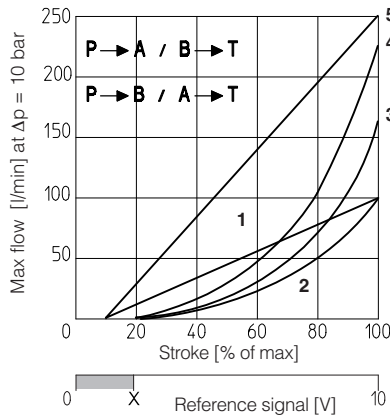

Note:

Hydraulic configuration vs reference signal for:
 - double solenoid valves (standard and option /B)

- Reference signal $0 \div +10 \text{ V}$ } P → A / B → T
 $12 \div 20 \text{ mA}$ }
- Reference signal $0 \div -10 \text{ V}$ } P → B / A → T
 $4 \div 12 \text{ mA}$ }

Hydraulic configuration vs reference signal for single solenoid valves:

- Reference signal:
 $0 \div +10 \text{ V}$ } P → A / B → T (standard)
 $4 \div 20 \text{ mA}$ } P → B / A → T (option /B)

X = Threshold for bias activation depending to the valve type and amplifier type

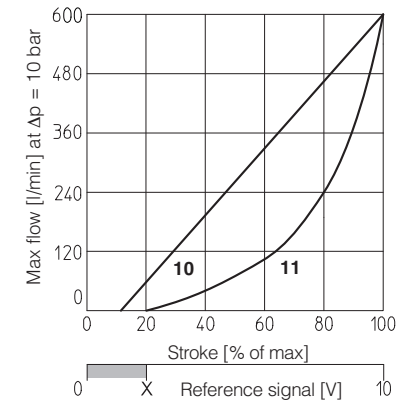
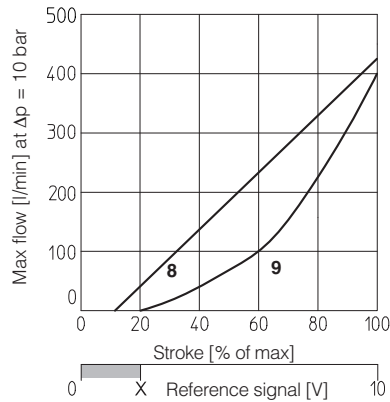

13.2 Flow /Δp diagram

Stated at 100% of valve stroke

- DPZO-1:
1 = spool L5, S5, D5
- DPZO-2:
2 = spool L5, S5, D5
3 = spool S3, D3
- DPZO-4:
4 = spool L5, S5, D5
- DPZO-6:
5 = spool L5, S5, D5

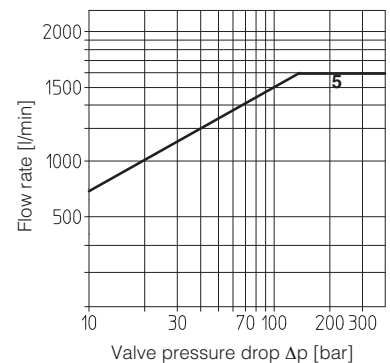
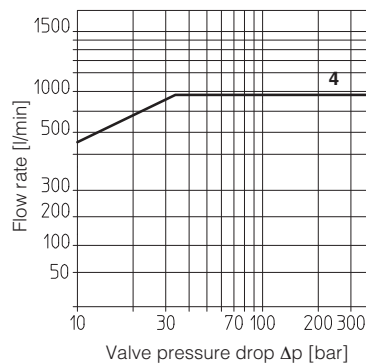
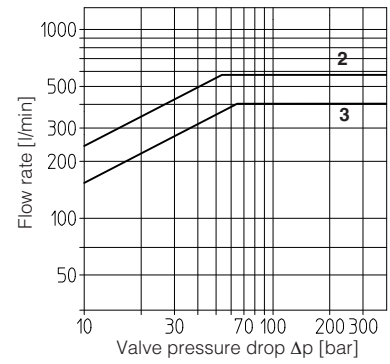
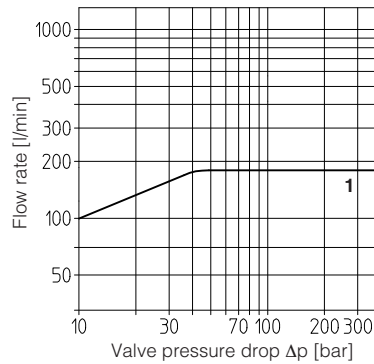

13.3 Operation as throttle valve

Single solenoid valves (*51) can be used as simple throttle valves:
 Pmax = 250 bar
 For this application, the use of valve -T, -TE or -TES (see tab. F172 and F175) is advisable (consult our technical office)

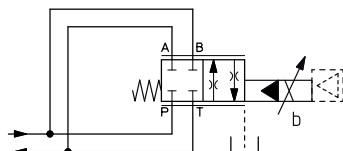

DPZO-*	151-L5	251-L5	451-L5	651-L5
Max flow [l/min]	320	850	1400	2000
Δp [bar]	30	30	30	30

DPZO-A(*)-1 (dotted line = double solenoid version)

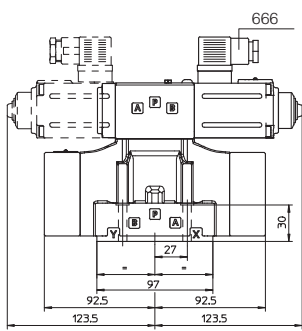

DPZO-A-1

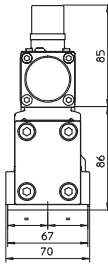

ISO 4401: 2005

Mounting surface: 4401-05-05-0-05 (see table P005)

Fastening bolts:

4 socket head screws M6x40 class 12.9

Tightening torque = 15 Nm

Seals: 5 OR 2050; 2 OR 108

Diameter of ports A, B, P, T: $\varnothing = 11$ mm;

Diameter of ports X, Y: $\varnothing = 5$ mm;

Mass [kg]

	A	AE, AES, AEG, AEZ	AES-EH
DPZO-*-15*	7,7	8,1	8,2
DPZO-*-17*	8,6	9	9,1

DPZO-AE-1

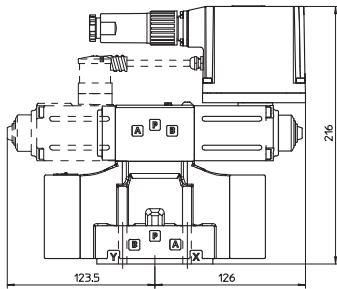

DPZO-AES-1

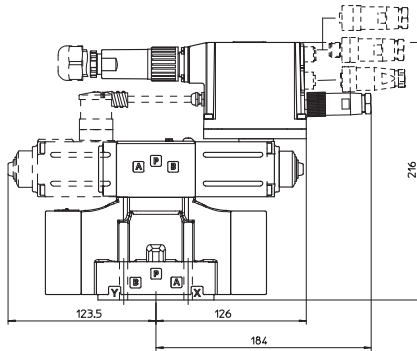

DPZO-AES-EH-1

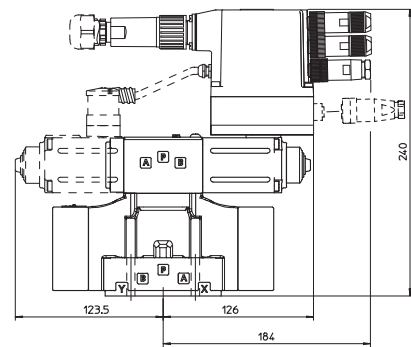

DPZO-A(*)-2 (dotted line = double solenoid version)

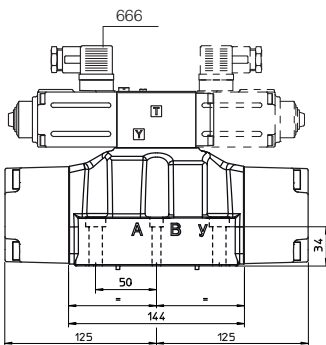

DPZO-A-2

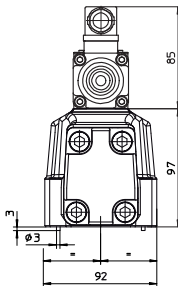

ISO 4401: 2005

Mounting surface: 4401-07-07-0-05 (see table P005)

Fastening bolts:

4 socket head screws M10x50 class 12.9

Tightening torque = 70 Nm

2 socket head screws M6x45 class 12.9

Tightening torque = 15 Nm

Seals: 4 OR 130; 3 OR 109/70

Diameter of ports A, B, P, T: $\varnothing = 20$ mm;

Diameter of ports X, Y: $\varnothing = 7$ mm;

Mass [kg]

	A	AE, AES, AEG, AEZ	AES-EH
DPZO-*-25*	11,9	12,3	12,4
DPZO-*-27*	12,8	13,2	13,3

DPZO-AE-2

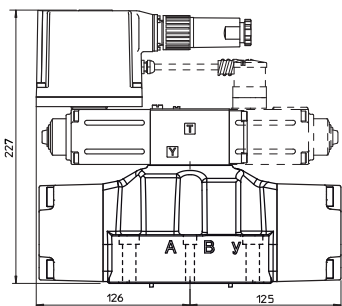

DPZO-AES-2

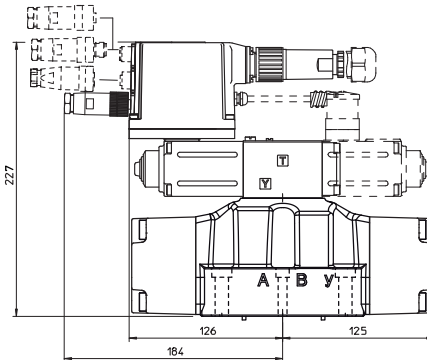

DPZO-AES-EH-2

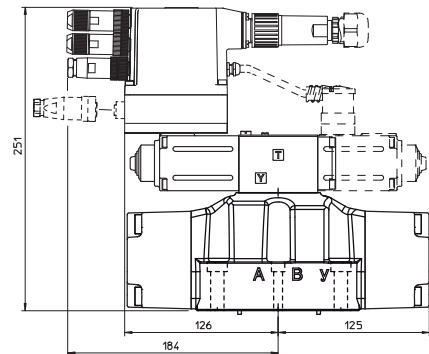

For main and communication connector see section 18, 19

NOTE: The overall height is increased by 40 mm for /G option (0,9 kg).

For option /B the proportional solenoid and the electronics (in case of execution -AE and -AES) are at side of port B of the main stage.

DPZO-A(*)-4 (dotted line = double solenoid version)

ISO 4401: 2005

Mounting surface: 4401-08-08-0-05 (see table P005)

Fastening bolts:

6 socket head screws M12x60 class 12.9

Tightening torque = 125 Nm

Seals: 4 OR 4112; 2 OR 3056

Diameter of ports A, B, P, T: $\varnothing = 24$ mm;

Diameter of ports X, Y: $\varnothing = 7$ mm;

Mass [kg]

	A	AE, AES, AEG, AEZ	AES-EH
DPZO-*45*	17,1	18	18,1
DPZO-*47*	18	18,9	19

DPZO-A-4

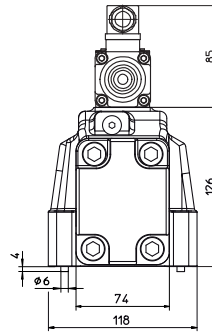
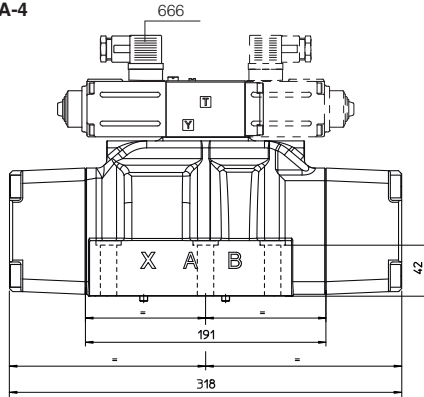

DPZO-AE-4

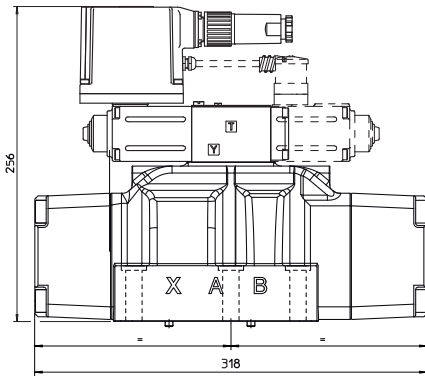

DPZO-AES-4

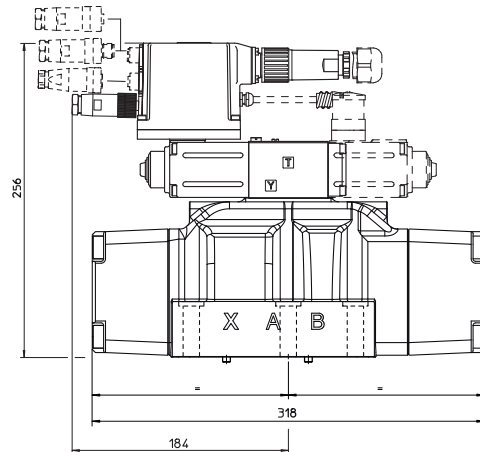

DPZO-AES-EH-4

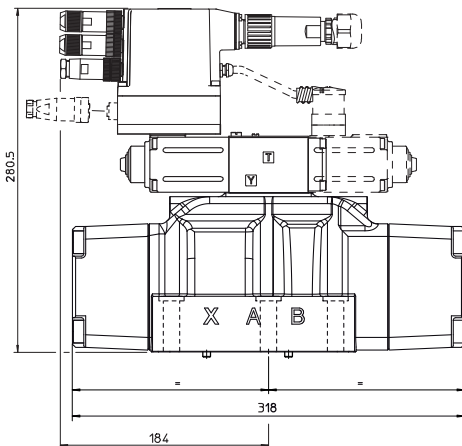

For main and communication connector see section 18, 19

NOTE: The overall height is increased by 30 mm for /G option (0,9 kg).

For option /B the proportional solenoid and the electronics (in case of execution -AE and -AES) are at side of port B of the main stage.

DPZO-A(*)-6 (dotted line = double solenoid version)

ISO 4401: 2005

Mounting surface: 4401-10-09-0-05

Fastening bolts:

6 socket head screws M20x90 class 12.9

Tightening torque = 600 Nm

Diameter of ports A, B, P, T: $\varnothing = 34$ mm;

Diameter of ports X, Y: $\varnothing = 7$ mm;

Seals: 4 OR 144, 3 OR 3056

Mass [kg]

	A	AE, AES, AEG, AEZ	AES-EH
DPZO-*-65*	42,1	42,5	42,6
DPZO-*-67*	42,7	43,1	43,2

DPZO-A-6

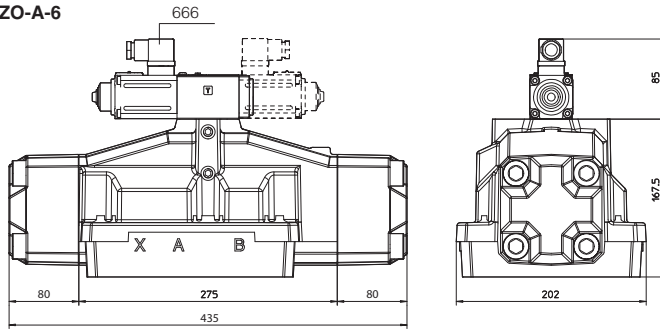

DPZO-AE-6

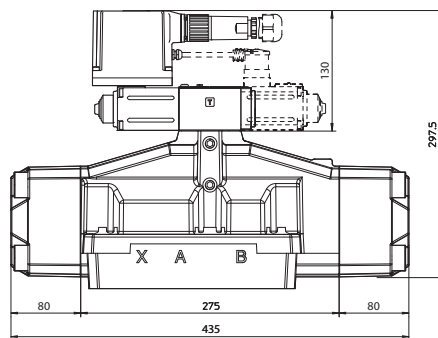

DPZO-AES-6

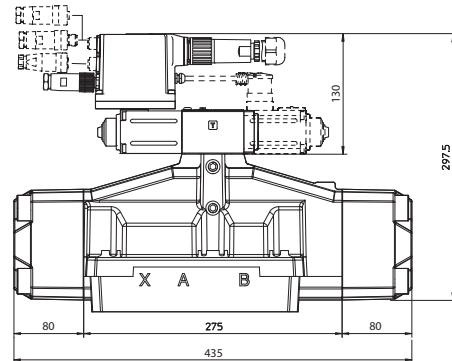

DPZO-AES-EH-6

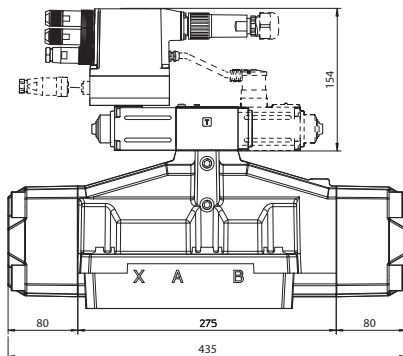

For main and communication connector see section 18, 19

NOTE: The overall height is increased by 40 mm for /G option (0,9 kg).

For option /B the proportional solenoid and the electronics (in case of execution -AE and -AES) are at side of port B of the main stage.

17 PROGRAMMING TOOLS - see tech table **GS500**

Valve's functional parameters and configurations, can be easily set and optimized using Atos E-SW programming software connected to the digital driver. E-SW software is available in different versions according to the driver's communication interface: PS (Serial) E-SW-PS, BC (CANopen) E-SW-BC, BP (PROFIBUS DP) and EH (EtherCAT). Proportional valves with fieldbus communication interface can be directly managed by the machine control unit; it is required to implement in the machine control the standard communication as described in the user manuals supplied with the relevant programming software.

18 CONNECTORS

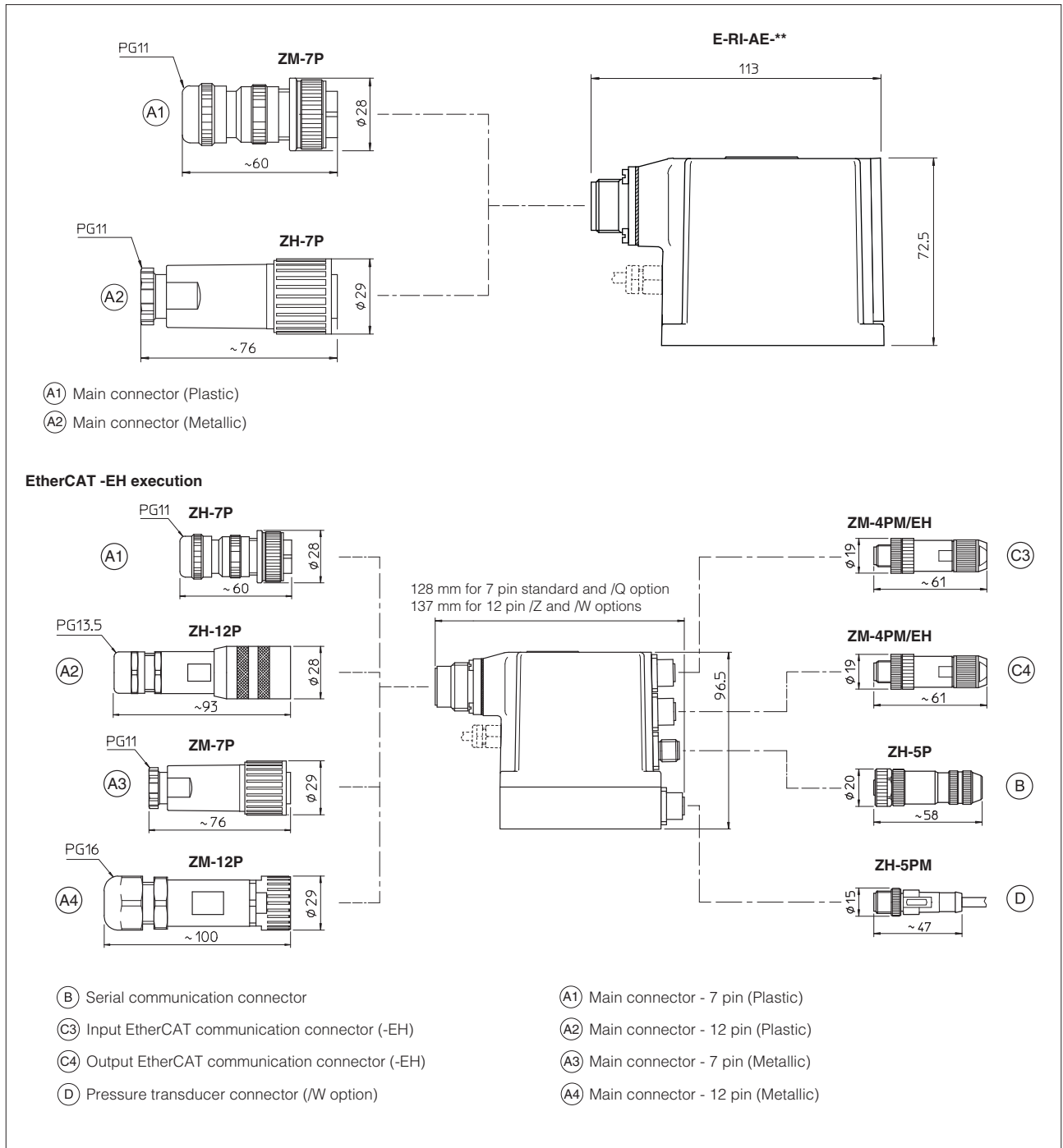

19 MODEL CODES OF POWER SUPPLY AND COMMUNICATION CONNECTORS (to be ordered separately)

VALVE VERSION	-A	-AE, -AES		-AES/Z	-AES/W -AEZ	CANopen (-BC)	PROFIBUS DP (-BP)	EtherCAT (-EH)
CONNECTOR CODE	666	ZH-7P	ZM-7P	ZH-12P	ZH-5PM	ZH-5P	ZH-5P/BP	ZM-4PM/EH
PROTECTION DEGREE	IP65	IP67	IP67	IP67	IP67	IP67	IP67	IP67
DATA SHEET	K500	G110, G115, K500			G115, K500		G115, K500	

connectors supplied with the valve