

Proportional flow valves type **QVHZO-AES, QVKZOR-AES**

pressure compensated, direct operated, without position transducer, ISO 4401 size 06 and 10

**AES execution included in this table is available only for running supplies or spare parts
For new applications it is suggested new AEB and AES executions, see table FS410**

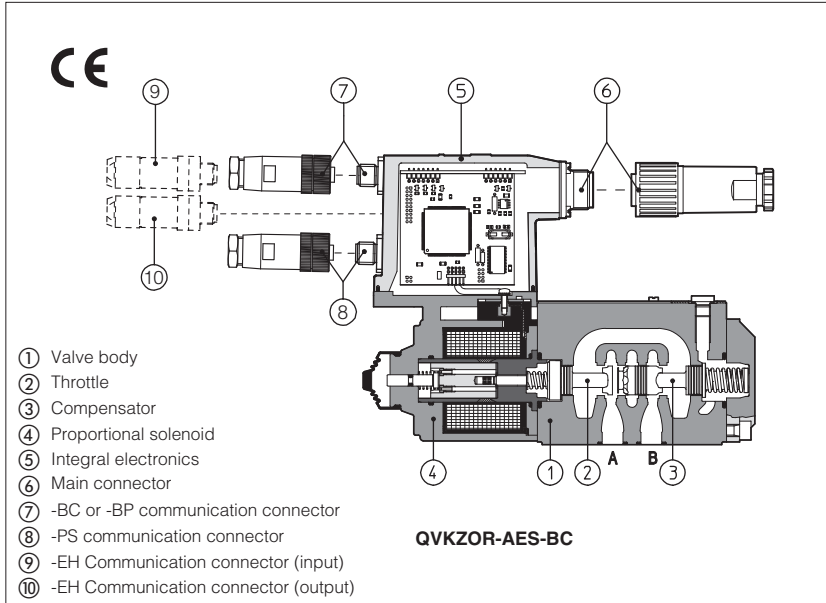

QVHZO and QVKZOR are 2 or 3 flow proportional valves, direct operated without position transducer, which provide compensated flow control according to the electronic reference signal.

They operate in association with electronic drivers, see section 2 which supply the proportional valves with correct current signal to align valve regulation to the reference signal supplied to the electronic driver.

They are available in different executions:

- -A, without position transducer;
- -AE, -AES, as -A plus analogue (AE) or digital (AES) integral electronics;

The flow is controlled by a throttle ②, directly operated by the proportional solenoid ④. The mechanical pressure compensator ③ keeps a constant Δp across the throttle ①, thus the regulated flow is independent to the load conditions.

The integral electronics ⑤ ensures factory presetting, fine functionality plus valve-to-valve interchangeability and simplified wiring and installation.

The electronic main connector ⑦ is fully interchangeable for -AE and -AES executions. Standard 7 pin connector is used for power supply, analog input reference and monitor signals.

12 pin connector is used for option /Z and option /W (AES).

Following communication interfaces ⑥ are available for the digital -AES execution:

- -PS, Serial communication interface for configuration, monitoring and firmware updating through Atos PC software - always present also for -BC, -BP and -EH options
- -BC, CANopen interface
- -BP, PROFIBUS-DP interface
- -EH, EtherCAT interface

The valves with -BC and -BP interfaces can be integrated into a fieldbus communication network and thus digitally operated by the machine control unit.

The coils are fully plastic encapsulated with insulation class H.

Surface mounting: ISO 4401, size 06 and 10.

Max flow respectively up to:

QVHZO = 45 l/min

QVKZOR = 90 l/min

Max pressure = 210 bar

1 MODEL CODE

QVKZOR -AES - PS - 10 / 65 / * ** / *

Pressure compensated flow control valves

QVHZO = size 06
QVKZOR = size 10

A = without position transducer
AE = as A plus integral electronics
AES = as A plus integral digital electronics

Communication interfaces (only for AES):

PS = Serial (1)
BC = CANopen
BP = PROFIBUS DP
EH = EtherCAT

Valve size:

06 = ISO 4401, size 06 **10** = ISO 4401, size 10

Max regulated flow:

for **QVHZO**:

3 = 3.5 l/min **36** = 35 l/min
12 = 12 l/min **45** = 45 l/min
18 = 18 l/min

for **QVKZOR**:

65 = 65 l/min
90 = 90 l/min

Seals material:
omit for NBR (mineral oil & water glycol)
PE = FPM

Series number

Coil voltage (only for -A execution)

see section 6:

- = standard coil for 24V_{DC} Atos drivers

6 = optional coil for 12V_{DC} Atos drivers

18 = optional coil for low current drivers

D = quick venting

N = manual micrometric adjustment

NV = as N plus handwheel and graduated scale

Electronics options for -AE execution,

see section 8:

I = current reference (4÷20 mA)

Q = enable signal

Electronics options for -AES execution,

see section 10.3:

Q = enable signal

Z = double power supply, enable fault and monitor (12 pin connector)

W = power limitation function (12 pin connector), see section 10.3

Note: (1) Serial interface always present, also for -BC and -BP options

2 ELECTRONIC DRIVERS FOR QVHZO AND QVKZOR

Valve model	-A						-AE	-AES
Drivers model	E-MI-AC-01F	E-MI-AS-IR	E-BM-AC-01F	E-BM-AS-PS	E-ME-AC-01F	E-RP-AC-01F	E-RI-AE	E-RI-AES
Data sheet	G010	G020	G025	G030	G035	G100	G110	G115

Note: for power supply and communication connector see section 13

3 HYDRAULIC CHARACTERISTICS (based on mineral oil ISO VG 46 at 50 °C)

Hydraulic symbols Note: In three-way versions port P is open. In two-way versions port P must be plugged. Port T must always be plugged.								
Valve model	QVHZO-A*-06					QVKZOR-A*-10		
Max regulated flow [l/min]	3,5	12	18	35	45	65	90	
Min regulated flow (1) [cm³/min]	15	20	30	50	60	85	100	
Regulating Δp [bar]	4 - 6		10 - 12		15	6 - 8	10 - 12	
Max flow on port A [l/min]	40		35	50	55	70	100	
Max pressure [bar]	210							
Response time 0÷100% step signal (2) [ms]	30					45		
Hysteresis [% of the regulated max flow]	≤ 5					≤ 5		
Linearity [% of the regulated max flow]	≤ 3					≤ 3		
Repeatability [% of the regulated max flow]	≤ 1					≤ 1		

Notes: Above performance data refer to valves coupled with Atos electronic drivers, see sections 2.

(1) Values are referred to 3-way configuration. In the 2-way configuration, the values of min regulated flow are higher.

(2) Response times at step signal (0%→100%) are measured from 10% to 90% of step value and are strictly referred to the valve regulation.

4 MAIN CHARACTERISTICS

Assembly position	Any position					
Subplate surface finishing	Roughness index Ra 0,4 - flatness ratio 0,01/100 (ISO 1101)					
Ambient temperature	-20°C ÷ +70°C for -A executions; -20°C ÷ +60°C for -AE and -AES					
Fluid	Hydraulic oil as per DIN 51524 ... 535 for other fluids see section 11					
Recommended viscosity	15 ÷ 100 mm²/s at 40°C (ISO VG 15÷100)					
Fluid contamination class	ISO 4406 class 20/18/15 NAS 1638 class 9, in line filters of 10 μm (β ₁₀ ≥75 recommended)					
Fluid temperature	-20°C +60°C (standard seals) -20°C +80°C (IPE seals)					
Valve model	QVHZO-A*			QVKZOR-A*		
	Standard	option /6	option /18	Standard	option /6	option /18
Coil resistance R at 20°C	3 ÷ 3,3 Ω	2 ÷ 2,2 Ω	13 ÷ 13,4 Ω	3,8 ÷ 4,1 Ω	2,2 ÷ 2,4 Ω	12 ÷ 12,5 Ω
Max. solenoid current	2,2 A	2,75 A	1,2 A	2,6 A	3,25 A	1,2 A
Max. power	30 Watt for QVHZO-A executions; 35 Watt for QVKZOR-A executions; 50 Watt for -AE and -AES					
Protection degree (CEI EN-60529)	IP65 for -A executions; IP67 for -AE and -AES					
Duty factor	Continuous rating (ED=100%)					

5 GENERAL NOTES

QVHZO and QVKZOR proportional valves are CE marked according to the applicable Directives (e.g. Immunity/Emission EMC Directive and Low Voltage Directive).

Installation, wirings and start-up procedures must be performed according to the general prescriptions shown in table F003 and in the installation notes supplied with relevant components.

The electrical signals of the valve (e.g. monitor signals) must not be directly used to activate safety functions, like to switch-ON/OFF the machine's safety components, as prescribed by the European standards (Safety requirements of fluid technology systems and components-hydraulics, EN-982).

6 OPTIONS FOR -A EXECUTION

5.1 Option /6 optional coil to be used with Atos drivers with power supply 12 Vdc

5.2 Option /18 optional coil to be used with electronic drivers not supplied by Atos

5.3 Option /D This option provides a quick venting of the user line when the valve is closed or de-energized.

The following options allow to operate the valve in absence of electrical power supply by means of a micrometric screw replacing the standard solenoid manual override, see table K500

5.4 Option /N manual micrometric adjustment

5.5 Option /NV as N plus handwheel and graduated scale

7 CONNECTION FOR -A EXECUTION

SOLENOID POWER SUPPLY CONNECTOR	
PIN	Signal description
1	SUPPLY
2	SUPPLY
3	GND

8 ANALOG INTEGRAL DRIVERS -AE - OPTIONS

Standard driver execution provides on the 7 pin main connector:

- Power supply** - 24Vdc must be appropriately stabilized or rectified and filtered; a 2.5 A safety fuse is required in series to the driver power supply. Apply at least a 10000 μ F/40 V capacitance to single phase rectifiers or a 4700 μ F/40 V capacitance to three phase rectifiers
- Reference input signal** - analog differential input with 0÷+10Vdc nominal range (pin D,E), proportional to desired coil current
- Monitor output signal** - analog output signal proportional to the actual valve's coil current (1V monitor = 1A coil current)

Following options are available to adapt standard execution to special application requirements:

8.1 Option /I

It provides the 4÷20 mA current reference signal instead of the standard 0÷+10 Vdc. Monitor output signal is still the standard 0÷+10Vdc.

It is normally used in case of long distance between the machine control unit and the valve or where the reference signal can be affected by electrical noise; the valve functioning is disabled in case of reference signal cable breakage.

8.2 Option /Q

It provides the possibility to enable or disable the valve functioning without cutting the power supply (the valve functioning is disabled but the driver current output stage is still active). To enable the driver supply a 24Vdc on the enable input signal.

8.3 Possible combined option: /IQ

9 ANALOG INTEGRAL DRIVERS -AE - MAIN FUNCTIONS AND ELECTRONIC CONNECTIONS

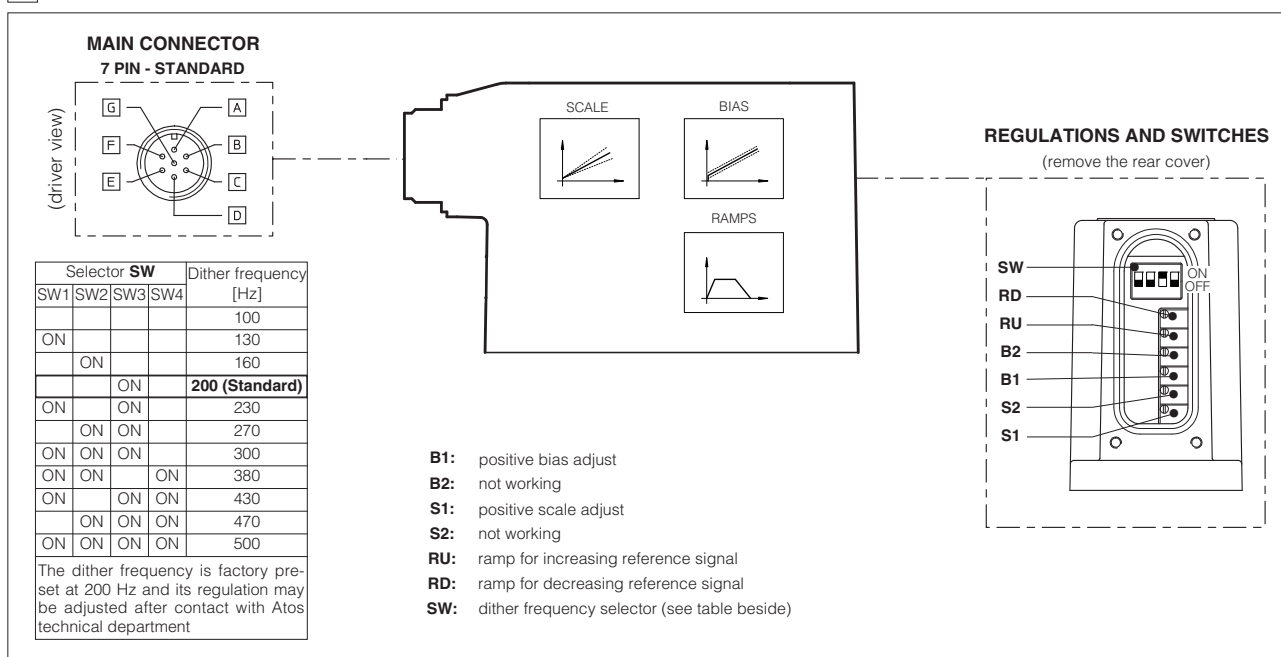

9.1 7 PIN MAIN CONNECTORS

PIN	SIGNAL	TECHNICAL SPECIFICATIONS	NOTES
A	V+	Power supply 24 Vdc for solenoid power stage and driver logic	Input - power supply
B	V0	Power supply 0 Vdc for solenoid power stage and driver logic	Gnd - power supply
C ⁽¹⁾	AGND	Ground - signal zero for MONITOR signal	Gnd - analog signal
	ENABLE	Enable (24 Vdc) or disable (0 Vdc) the driver (for /Q option)	Input - on/off signal
D	INPUT+	Reference analog differential input: ± 10 Vdc maximum range (4 ÷ 20 mA for /I option)	Input - analog signal
E	INPUT -	Default setting for single solenoid valves: 0÷+10 Vdc	
F	MONITOR	Monitor analog output: 0÷+5 Vdc maximum range; 1 V = 1 A	Output - analog signal
G	EARTH	Internally connected to the driver housing	

Note: (1) with /Q option ENABLE signal replaces AGND on pin C; MONITOR signal is referred to pin B.

A minimum time of 60ms to 160ms have to be considered between the driver energizing with the 24 Vdc power supply and when the valve is ready to operate. During this time the current to the valve coils is switched to zero

10 DIGITAL INTEGRAL DRIVERS -AES - OPTIONS

Standard driver execution provides on the 7 pin main connector:

Power supply - 24Vdc must be appropriately stabilized or rectified and filtered; a 2,5 A safety fuse is required in series to each driver power supply. Apply at least a 10000 µF/40 V capacitance to single phase rectifiers or a 4700 µF/40 V capacitance to three phase rectifiers.

Reference input signal - analog differential input with 0÷+10 Vdc nominal range (pin D, E), proportional to desired coil current (4÷20 mA with cable break detection, ±10 mA, ±20 mA or 0÷20 mA software selectable)

Monitor output signal - analog output signal proportional to the actual valve's coil current (1V monitor = 1A coil current)

Following options are available to adapt standard execution to special application requirements:

10.1 Option /Q

To enable the driver, supply 24Vdc on pin C referred to pin B: when the enable signal is set to zero the valve status is software selectable, by factory default the valve functioning is disabled (zero current to the solenoid) but the driver current output stage is still active. For the complete list of selectable status, see tab. G115.

10.2 Option /Z

It provides, on the 12 pin main connector, the following additional features:

Logic power supply

Separated power supply for the solenoid (pin 1, 2) and for the digital electronic circuits (pin 9, 10).

Cutting solenoid power supply allows to interrupt the valve functioning but keeping energized the digital electronics thus avoiding fault conditions of the machine fieldbus controller. This condition allows to realize safety systems in compliance with European Norms EN13849-1 (ex EN954-1).

Enable Input Signal

To enable the driver, supply 24Vdc on pin 3 referred to pin 2: when the enable signal is set to zero the valve status is software selectable, by factory default the valve functioning is disabled (zero current to the solenoid) but the driver current output stage is still active. For the complete list of selectable status, see tab. G115.

Fault Output Signal

Fault output signal indicates fault conditions of the driver (solenoid short circuits/not connected, reference signal cable broken for 4÷20mA input, etc.). Fault presence corresponds to 0 Vdc, normal working corresponds to 24Vdc (pin 11 referred to pin 2): Fault status is not affected by the Enable input signal.

10.3 Option /W

It provides, on the 12 pin main connector, the above option /Z features plus the hydraulic power limitation function.

The driver receives the flow reference signal by the analog external input INPUT+ and a pressure transducer remotely installed in the hydraulic system, has to be connected to the driver's analog input TR.

When the actual requested hydraulic power $p \times Q$ (TR x INPUT+) reaches the max power limit ($p \times Q1$), internally set by software, the driver automatically reduces the flow regulation of the valve. The higher is the pressure feedback the lower is the valve's regulated flow:

$$\text{Flow regulation} = \text{Min} \left(\frac{\text{PowerLimit [sw setting]}}{\text{Transducer Pressure [TR]}} ; \text{Flow Reference [INPUT+]} \right)$$

For detailed information on hydraulic power limitation, see tab. G115

11 DIGITAL INTEGRAL DRIVERS -AES - MAIN FUNCTIONS AND ELECTRONIC CONNECTIONS

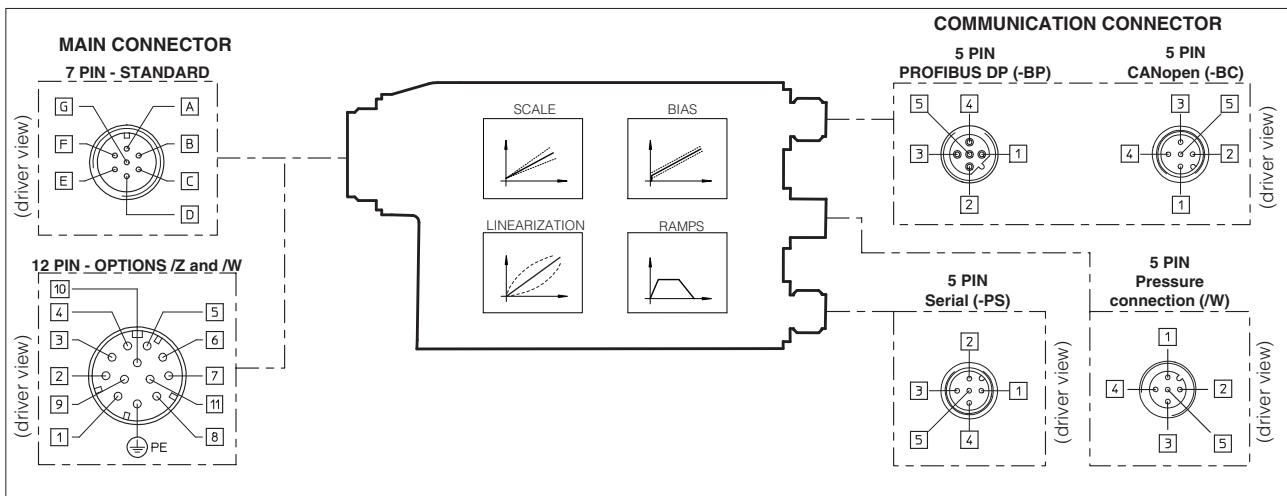

11.1 7 & 12 PIN MAIN CONNECTORS

Standard 7pin	/Z, /W options 12pin	SIGNAL	TECHNICAL SPECIFICATIONS	NOTES
A	1	V+	Power supply 24 Vdc for solenoid power stage (and for driver logic on 7 pin connection)	Input - power supply
B	2	V0	Power supply 0 Vdc for solenoid power stage (and for driver logic on 7 pin connection)	Gnd - power supply
C (option /Q)	3	ENABLE	Enable (24 Vdc) or disable (0 Vdc) the driver	Input - on/off signal
D	4	INPUT+	Reference analog input: ±10 Vdc / ±20 mA maximum range software selectable	Input - analog signal
E	-	INPUT -	Default setting for single solenoid valves: 0÷+10 Vdc, differential input /Z and /W options: common mode INPUT+ referred to AGND	
C	5	AGND	Ground - signal zero for MONITOR signal (INPUT+ signal only for /Z and /W options)	Gnd - analog signal
F	6	MONITOR	Monitor analog output: 0÷+10 Vdc maximum range; Default setting 1V = 1A	Output - analog signal
-	7	NC	do not connect	
-	8	MONITOR 2	2nd monitor analog output: ±5 Vdc maximum range (only for /W option)	
-	9	VL+	Power supply 24 Vdc for driver logic	Input - power supply
-	10	VLO	Power supply 0 Vdc for driver logic	Gnd - power supply
-	11	FAULT	Fault (0 Vdc) or normal working (24 Vdc)	Output - on/off signal
G	PE	EARTH	Internally connected to the driver housing	

Note: A minimum time of 270 to 340 ms have be considered between the driver energizing with the 24Vdc power supply and when the valve is ready to operate. During this time the current to the valve coils is switched to zero.

11.2 ELECTRONIC CONNECTIONS - 5 PIN COMMUNICATION AND PRESSURE TRANSDUCER CONNECTORS

PIN	Serial (-PS)		CANopen (-BC)		PROFIBUS DP (-BP)	
	SIGNAL	TECHNICAL SPECIFICATION	SIGNAL	TECHNICAL SPECIFICATION	SIGNAL	TECHNICAL SPECIFICATION
1	NC	do not connect	CAN_SHLD	Shield	+5V	for termination
2	NC	do not connect	NC	do not connect	LINE-A	Bus line (high)
3	RS_GND	Signal zero data line	CAN_GND	Signal zero data line	DGND	data line and termination Signal zero
4	RS_RX	Valves receiving data line	CAN_H	Bus line (high)	LINE-B	Bus line (low)
5	RS_TX	Valves transmitting data line	CAN_L	Bus line (low)	SHIELD	do not connect

11.3 5 PIN M12 PRESSURE CONNECTOR (only for /W option)

PIN	Input Voltage (Software selectable)		Input Current (Software selectable)	
	SIGNAL	TECHNICAL SPECIFICATION	SIGNAL	TECHNICAL SPECIFICATION
1	VT	Remote transducer power supply 24 Vdc	VT	Remote transducer power supply 24 Vdc
2	TR	Remote transducer signal (0 ÷ 10 Vdc)	TR	Remote transducer signal (0 ÷ 20 mA)
3	AGND	signal zero for power supply and signal	NC	do not connect
4	NC	do not connect	NC	do not connect
5	NC	do not connect	NC	do not connect

12 DIGITAL INTEGRAL DRIVER -AES-EH - MAIN FUNCTIONS AND ELECTRONIC CONNECTIONS

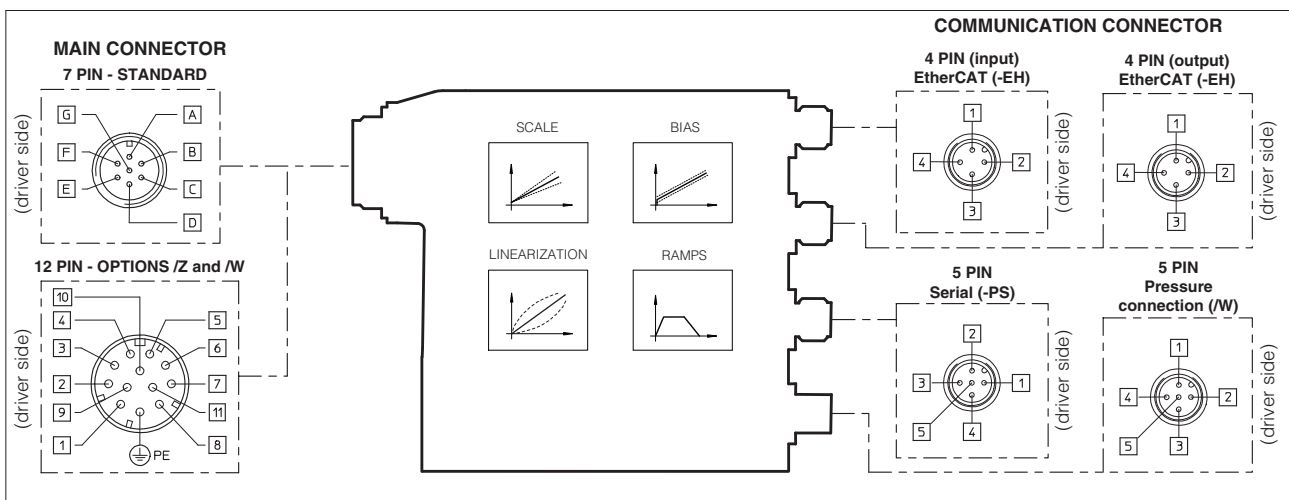

Note: for the electronic connections of 7 or 12 pin main connector, see section 12.1 for pressure transducer electronic connector (option /W) see section 11.3)

12.1 4 & 5 PIN M12 COMMUNICATION CONNECTORS

PIN	Serial (-PS)	
	SIGNAL	TECHNICAL SPECIFICATION
1	NC	do not connect
2	NC	do not connect
3	RS_GND	Signal zero data line
4	RS_RX	Valves receiving data line
5	RS_TX	Valves transmitting data line

PIN	EtherCAT (-EH)	
	SIGNAL	TECHNICAL SPECIFICATION
1	TX+	Transmitter
2	RX+	Receiver
3	TX-	Transmitter
4	RX-	Receiver
Housing	Shield	Positioned on control cabinet side

13 MODEL CODES OF POWER SUPPLY AND COMMUNICATION CONNECTORS (to be ordered separately)

VALVE VERSION	-A	-AE, -AES		-AES/Z	-AES/W	-Serial (-PS) or CANopen (-BC)	PROFIBUS DP (-BP)	EtherCAT (-EH)
CONNECTOR CODE	666	ZH-7P	ZM-7P	ZH-12P	ZH-5PM	ZH-5P	ZH-5P/BP	ZM-4PM/EH
PROTECTION DEGREE	IP65	IP67	IP67	IP67	IP67	IP67	IP67	IP67
DATA SHEET	K500	G110, G115, K500			G115, K500	G115, K500		

connectors supplied with the valve

14 PROGRAMMING TOOLS - see tech table GS500

Valve's functional parameters and configurations, can be easily set and optimized using Atos E-SW programming software connected to the digital driver. E-SW software is available in different versions according to the driver's communication interface: PS (Serial) E-SW-PS, BC (CANopen) E-SW-BC and BP (PROFIBUS DP). Proportional valves with fieldbus communication interface can be directly managed by the machine control unit; it is required to implement in the machine control the standard communication as described in the user manuals supplied with the relevant programming software.

15 **DIAGRAMS** (based on mineral oil ISO VG 46 at 50 °C)

15.1 Regulation diagrams

- 1 = QVHZO-*-06/3
- 2 = QVHZO-*-06/12
- 3 = QVHZO-*-06/18
- 4 = QVHZO-*-06/36
- 5 = QVHZO-*-06/45
- 6 = QVKZOR-*-10/65
- 7 = QVKZOR-*-10/90

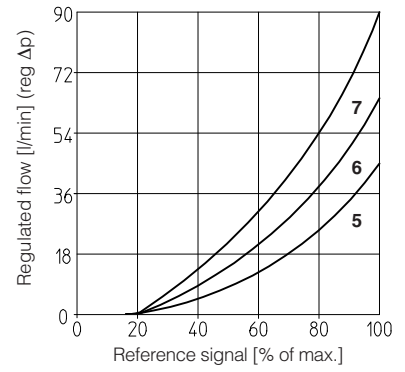
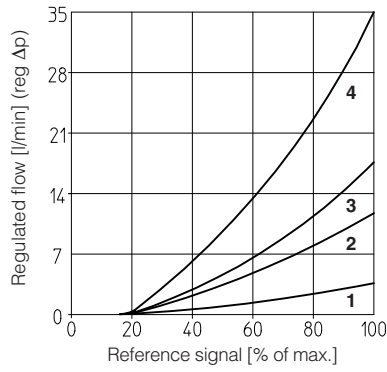

15.2 Regulated flow/outlet pressure diagrams
with inlet pressure = 210 bar

- 1 = QVHZO-*
- 2 = QVKZOR-*

Dotted line for 3-way versions

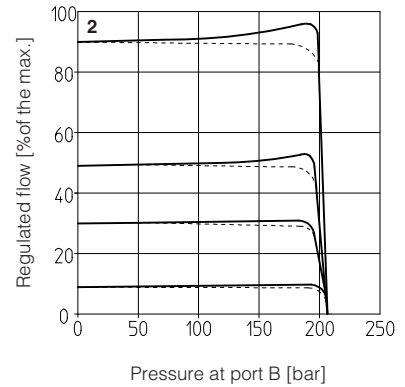
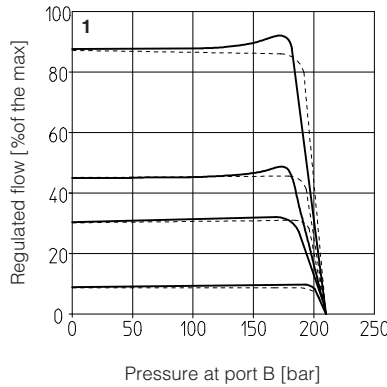

15.3 Flow A→P/Δp diagrams
3-way configuration

- 1 = QVHZO-*-06/3
- QVHZO-*-06/12
- 2 = QVHZO-*-06/18
- QVHZO-*-06/36
- 3 = QVHZO-*-06/45
- 4 = QVKZOR-*-10/65
- 5 = QVKZOR-*-10/90

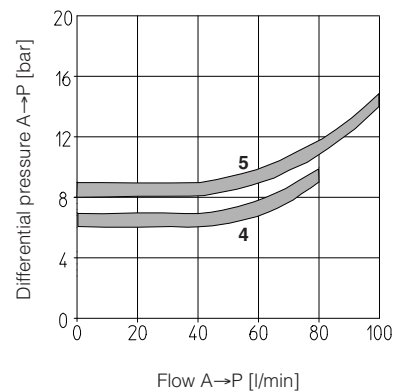
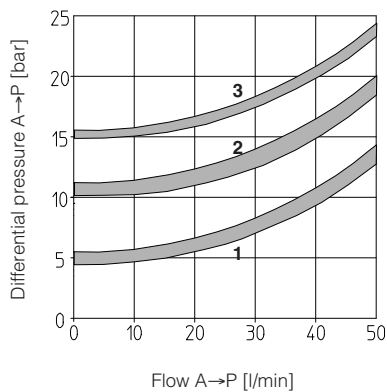

QVHZO-A*

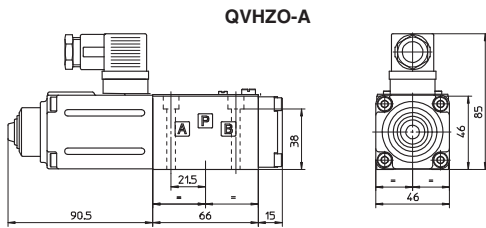

Mass: 2,3 kg

ISO 4401: 2005

Mounting surface: 4401-03-02-0-05 (see tab. P005)

Fastening bolts: 4 socket head screws M5x50 class 12.9

Tightening torque = 8 Nm

Seals: 4 OR 108;

Diameter of ports A, B, P, T:

Ø 7,5 mm (max)

QVHZO-AE

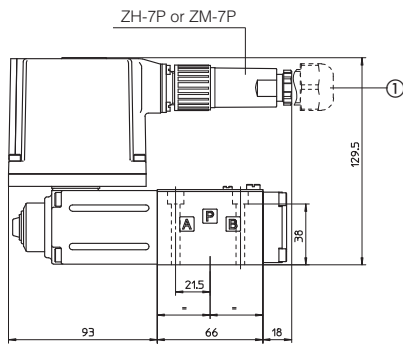

Mass: 2,9 kg

QVHZO-AES

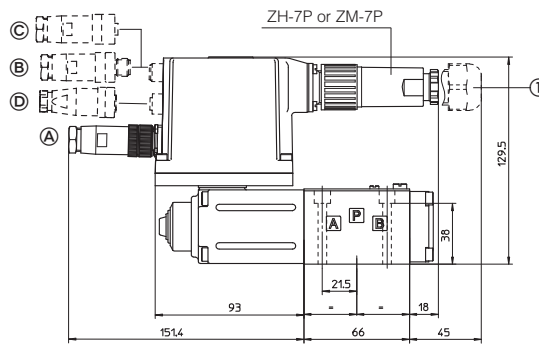

Mass: 3,1 kg

QVHZO-AES-EH

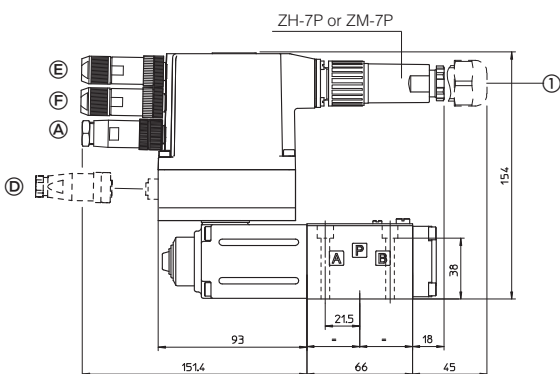

Mass: 3,2 kg

- Ⓐ -PS communication interface, ZH-5P connector
- Ⓑ -BP communication interface, ZH-5P/BP connector
- Ⓒ -BC communication interface, ZH-5P connector
- Ⓓ -Option /W pressure transducer interface, ZM-5PM connector
- Ⓔ -EH communication interface (input), ZM-4PM/EH connector
- Ⓕ -EH communication interface (output), ZM-4PM/EH connector

① dotted line = 12 pin connector ZH-12P for option /Z

QVKZOR-A*

QVKZOR-A

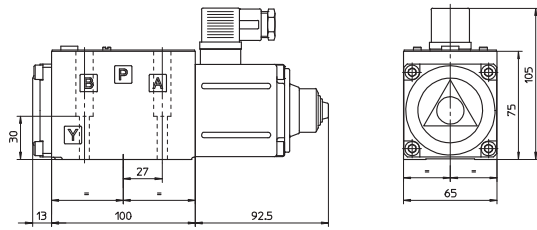

Mass: 3,8 kg

ISO 4401: 2005

Mounting surface: 4401-05-04-0-05 (see tab. P005)

Fastening bolts: 4 socket head screws M6x40 class 12.9

Tightening torque = 15 Nm

Seals: 5 OR 2050;

Diameter of ports A, B, P, T:

Ø 11,2 mm (max)

QVKZOR-AE

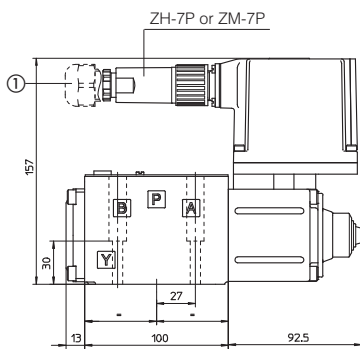

Mass: 4,4 kg

QVKZOR-AES

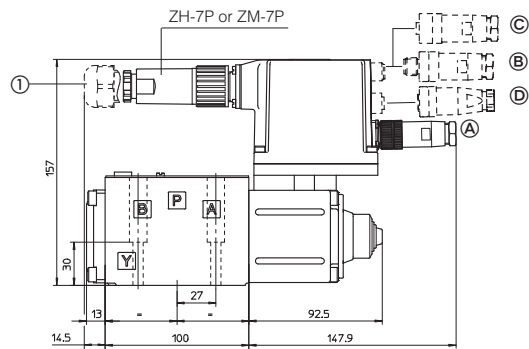

Mass: 4,6 kg

QVKZOR-AES-EH

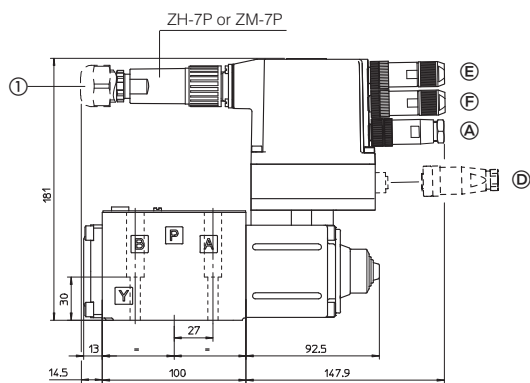

Mass: 4,7 kg

- Ⓐ -PS communication interface, ZH-5P connector
- Ⓑ -BP communication interface, ZH-5P/BP connector
- Ⓒ -BC communication interface, ZH-5P connector
- Ⓓ -Option /W pressure transducer interface, ZH-5PM connector
- Ⓔ -EH communication interface (input), ZM-4PM/EH connector
- Ⓕ -EH communication interface (output), ZM-4PM/EH connector

① dotted line = 12 pin connector ZH-12P for option /Z