

Digital electronic TES/LES drivers with S option

integral-to-valve format, for proportional valves with alternated P/Q control

DLHZO-TES-SP-BP PROFIBUS DP

DLHZO-TES-SF-EH EtherCAT

DLHZO-TES-SL-EW POWERLINK

SP
PRESSURE TRANSDUCER

SF
TWO PRESSURE TRANSDUCERS

SL
LOAD CELL

Scale

Bias

Linearization

Ramps

Real Time Fieldbus Reference

Enhanced Diagnostic

USB port

E-SW
programming software

Transducers ③ and connectors ④, ⑤, ⑥ not included, to be ordered separately

TES-S, LES-S

S option on digital drivers ① adds the closed loop control of pressure (SP) or force (SF and SL) to the basic functions of proportional directional valves flow regulation.

The P/Q alternated control operates according to the two electronic reference signals by a dedicated algorithm that automatically selects which control will be active time by time. The dynamics of the switching between the two controls can be regulated thanks to specific software setting, in order to avoid instability or vibrations.

Flow regulation is active when the actual system pressure/force is lower than the relevant input reference signal - the valve works normally to regulate the flow by controlling in closed-loop the spool/poppet position through the integral LVDT transducer ②.

Pressure/force control is activated when the actual system pressure/force, measured by remote transducers ③, grows up to the relevant input reference signal - the driver reduces the valve's flow regulation in order to keep steady the system pressure/force.

If the pressure/force tends to decrease under its input reference signal, the flow control returns active (see section [2]).

The dynamic response of pressure/force control can be adapted to different system's characteristics, by setting the internal PID parameters using Atos PC software.

Up to 4 different PIDs are selectable to optimize the system dynamic response according to different hydraulic working conditions.

Electrical features:

- 12 pin main connector ④ for power supply, additional double power supply, enable and fault signals
- 5 pin USB connector always present
- 3 leds for diagnostic (see 5.1)
- IN/OUT fieldbus communication connectors ⑤ for **BC** CANopen, **BP** PROFIBUS DP, **EH** EtherCAT, **EW** POWERLINK, **EI** EtherNet/IP (see section [7])
- 5 pin connectors ⑥ for single transducers
- Electrical protection against reverse polarity of power supply
- Operating temperature range -40° ÷ +60°
- IP66 / IP67 protection degree
- CE mark according to EMC directive

Software Features:

- Intuitive graphic interface
- Setting of valve's functional parameters
- Setting of PID gains
- Complete diagnostics of driver status
- Internal oscilloscope function
- In field firmware update through USB port

Alternated control configurations

| | SP | SF |
|--------------------------------------------------------------------------------------------|----------------------------------------------------------------------------------------------------------------------------------------------------|-------------------------------------------------------------------------------------------|
| | | |
| one remote pressure transducer has to be installed on the actuator's port to be controlled | two remote pressure transducers have to be installed on the actuator's ports; the actuator force is calculated by the pressure feedbacks (Pa - Pb) | one load cell transducer has to be installed between the actuator and the controlled load |

1 VALVES RANGE

| Valves model | Directional | | Directional | Cartridge |
|--------------|-----------------------------|-------------------------------|--------------|------------------------------|
| | DHZO DKZOR | DLHZO DLKZOR | DPZO | LIQZO LIQZP |
| Data sheet | FS165, F168 | FS180 | FS175, FS178 | FS340 |
| Driver model | TES-S | | LES-S | |

2 ALTERNATED P/Q CONTROLS APPLICATION EXAMPLES

The following applications examples are intended just as generic reference of the possible configurations with the digital integral electronics with **S** option. Alternated control is factory preset according to selected valve code and can be reconfigured via software selecting between **SP**, **SF**, **SL**. The Atos technical services are available for additional evaluations related to specific applications usage, please contact our technical office.

High-dynamic pressure reducing controls - only for SP

3 way or 4 way directional proportional valves with SP control, in subplate mounting or cartridge execution, are operated in 3-way hydraulic configuration to obtain high-dynamic pressure reducing control on the A user port (see 2.1):

- flow reference signal is used to limit the maximum flow during the pressure regulation
- pressure reference signal is used to regulate the pressure on the valve's A user port; the rapid/repeatable response of the pressure control is performed in high dynamics by the directional valve's closed loop regulation

- Requirements:**
- a remote pressure transducer has to be installed in the hydraulic system on the controlled user port (when using 4 way valves either A or B port can be used while the not controlled port must be plugged)
 - zero overlap spool and valve without fail safe position are recommended; positive overlap valves with PABT ports closed in central position has not to be used

Single effect actuators with speed/pressure (force) controls - only for SP or SL

3 way or 4 way directional proportional valves with SP or SL control, in subplate mounting or cartridge execution, are operated in 3-way hydraulic configuration to control speed/pressure (force) on single effect actuators (see 2.2):

- flow reference signal is used to regulate the actuator's forward and backward speed while pressure (force) reference signal is used to limit the maximum pushing pressure (force) to the actuator

- or
- pressure (force) reference signal is used to regulate the actuator pushing pressure (force) while flow reference signal is used to limit the maximum actuator speed

- Requirements:**
- for SP a remote pressure transducer has to be installed in the hydraulic system on the actuator pushing port (when using 4 way valves either A or B port can be used while the not controlled port must be plugged)
 - for SL a remote force transducer has to be installed between the actuator and the controlled load
 - zero overlap spool is recommended; positive overlap valves with PABT ports closed in central position has not to be used

Double effect actuators with speed/pressure controls - only for SP

4 way directional proportional valves with SP control, in subplate mounting execution, control speed/pressure on double effect actuators (see 2.3):

- flow reference signal is used to regulate the actuator's forward and backward speed while pressure reference signal is used to limit the maximum pushing pressure to the actuator

- or
- pressure reference signal is used to regulate the actuator pushing pressure while flow reference signal is used to limit the maximum forward and backward actuator speed

- Requirements:**
- a remote pressure transducer has to be installed on the actuator's pushing port
 - dedicated spool with strong "meter-in" characteristic in central position has to be used; during depressurizing phases the not controlled port remains at zero pressure (T port connection) - see section 3

Double effect actuators with force limit/regulation - only for SF or SL

4 way directional proportional valves with SF or SL control, in subplate mounting execution, control speed/force on double effect actuators (see 2.4, 2.5):

- flow reference signal is used to regulate the actuator's forward and backward speed while force reference signal is used to limit the maximum pushing and pulling force to the actuator

- or
- force reference signal is used to regulate the actuator pushing and pulling force while flow reference signal is used to limit the maximum actuator speed

- Requirements:**
- for SF two remote pressure transducers have to be installed on the both actuator's ports
 - for SL one push/pull load cell transducer has to be installed between the actuator and the controlled load
 - zero overlap spool is recommended; positive overlap valves with PABT ports closed in central position has not to be used

- Advantages:**
- force control is possible in both push and pull directions
 - SL allows a more precise force control despite of a more complex installation of the load cell transducer
 - SF allows to add force control also into existing systems thanks to the simple installation of pressure transducers

- Control modes:**
- Flow priority: flow reference signal is used to move forward and backward the actuator while force is limited/regulated in both push and pull direction
 - Force priority: force reference signal is used to control both push and pull forces while flow is limited/regulated in both direction

Notes:

- servoproportional type DLHZO, DLKZOR and DPZO-L are strongly recommended for high accuracy applications - see tech table **FS180**, **FS178**
- auxiliary check valves are recommended in case of specific hydraulic configuration requirements in absence of power supply or fault - see tech table **E115**

2.1 - 3 way connection SP

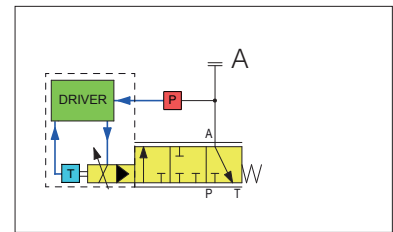

2.2 - 3 way connection SL

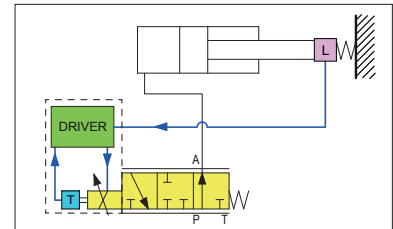

2.3 - 4 way connection SP

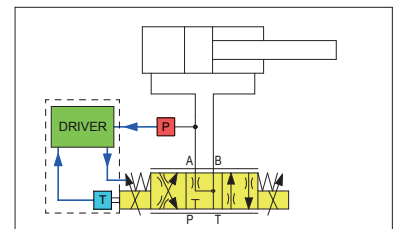

2.4 - 4 way connection SF

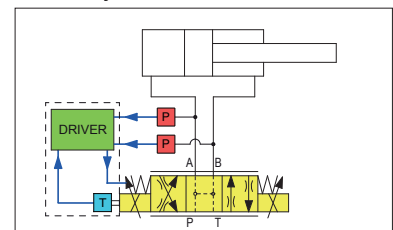

2.5 - 4 way connection SL

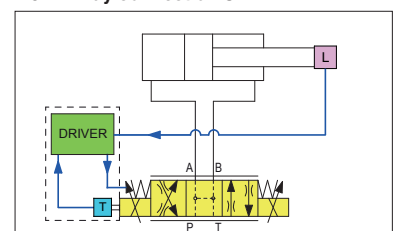

2.6 - Flow priority

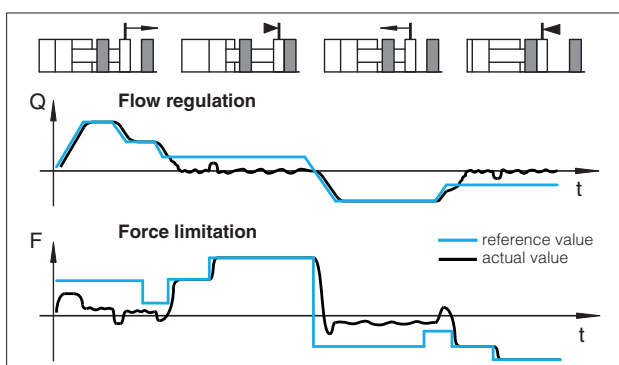

2.7 - Force priority

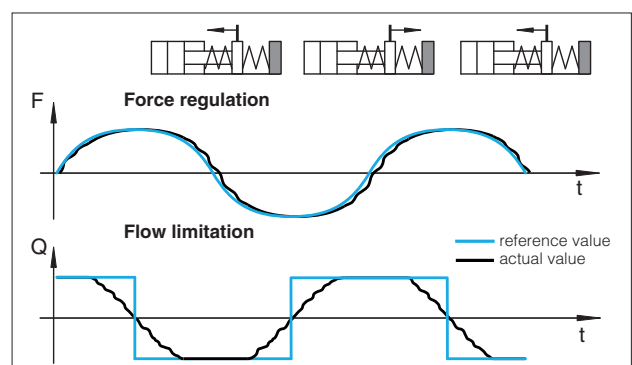

3 OPTIONAL SPOOLS FOR 4 WAY CONNECTION WITH SP CONTROL

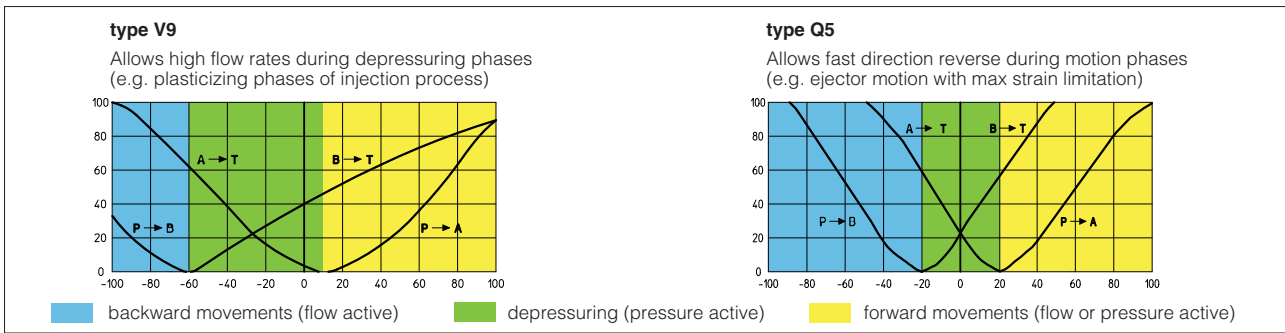

4 MAIN CHARACTERISTICS

| | |
|-----------------------------------------|---------------------------------------------------------------------------------------------------------------------------------------------------------------------------------------------------|
| Power supplies (see 6.1, 6.4) | Nominal : +24 V _{DC} Rectified and filtered : $V_{RMS} = 20 \div 32 V_{MAX}$ (ripple max 10 % V _{PP}) |
| Max power consumption | 50 W |
| Reference input signals (see 6.2) | Voltage: range $\pm 10 V_{DC}$ (24 V _{MAX} tollerant) Input impedance: $R_i > 50 k\Omega$ Current: range $\pm 20 mA$ Input impedance: $R_i = 500 \Omega$ |
| Monitor outputs (see 6.3) | Output range: voltage $\pm 10 V_{DC}$ @ max 5 mA current $\pm 20 mA$ @ max 500 Ω load resistance |
| Enable input (see 6.5) | Range: 0 \div 5 V _{DC} (OFF state), 9 \div 24 V _{DC} (ON state), 5 \div 9 V _{DC} (not accepted); Input impedance: $R_i > 10 k\Omega$ |
| Fault output (see 6.6) | Output range: 0 \div 24 V _{DC} (ON state $>$ [power supply - 2 V] ; OFF state $<$ 1 V) @ max 50 mA; external negative voltage not allowed (e.g. due to inductive loads) |
| Alarms | Solenoid not connected/short circuit, cable break with current reference signal, over/under temperature, valve spool transducer malfunctions |
| Pressure/Force transducers power supply | +24 V _{DC} @ max 100 mA |
| Format | Sealed box on the valve; IP66 / IP67 protection degree with mating connectors |
| Tropicalization | Tropical coating on electronics PCB |
| Operating temperature | -40 \div +60 °C (storage -40 \div +70 °C) |
| Mass | Approx. 510 g |
| Additional characteristics | Short circuit protection of solenoid's current supply; 3 leds for diagnostic; pressure/force control by P.I.D. with rapid solenoid switching; protection against reverse polarity of power supply |
| Electromagnetic compatibility (EMC) | According to Directive 2014/30/UE (Immunity: EN 61000-2; Emission: EN 61000-3) |
| Communication interface | USB Atos ASCII coding CANopen EN50325-4 + DS408 PROFIBUS DP EN50170-2/IEC61158 EtherCAT, POWERLINK, EtherNet/IP IEC 61158 |
| Communication physical layer | not insulated USB 2.0 + USB OTG optical insulated CAN ISO11898 optical insulated RS485 Fast Ethernet, insulated 100 Base TX |
| Recommended wiring cable (see 12) | LIYCY shielded cables |

Note: a minimum booting time between 400 and 800 ms has be considered from the driver energizing with the 24 V_{DC} power supply before the valve has been ready to operate. During this time the current to the valve coils is switched to zero

5 CONNECTIONS AND LEDS

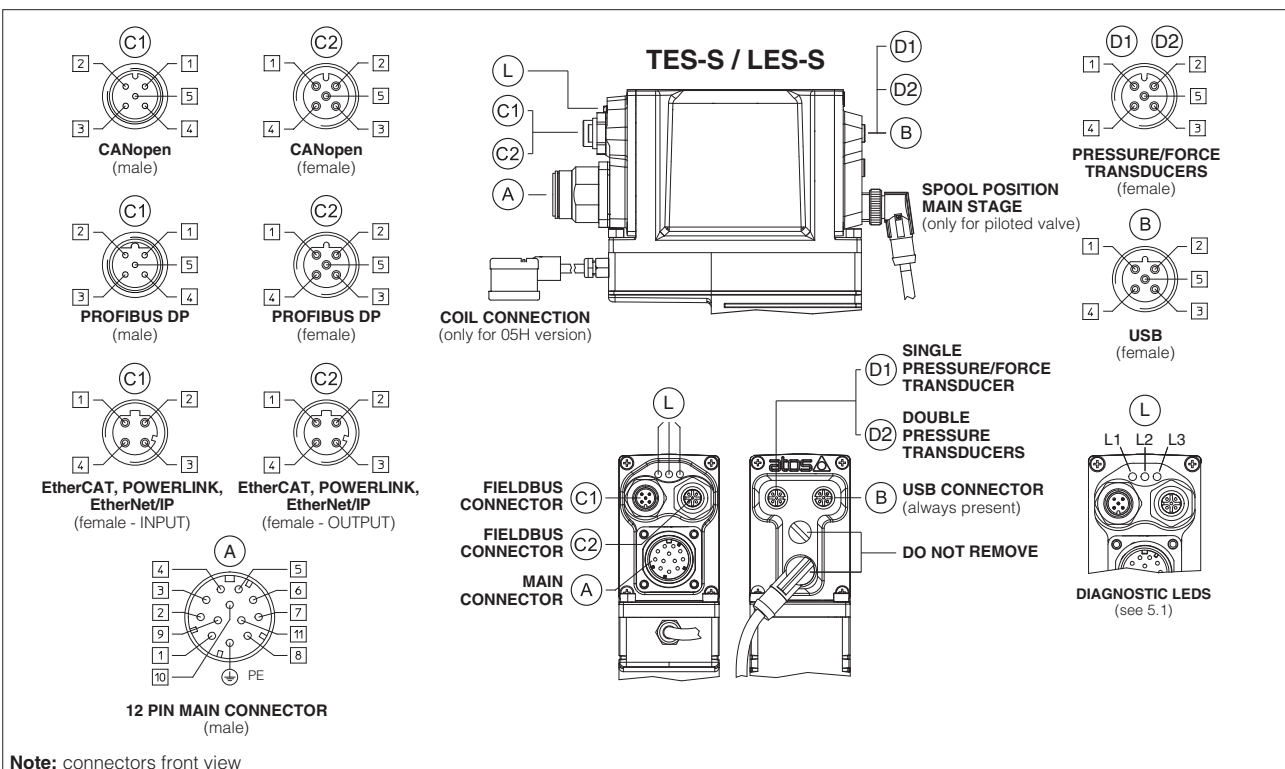

5.1 Diagnostic LEDs L

Three leds show driver operative conditions for immediate basic diagnostics. Please refer to the driver user manual for detailed information.

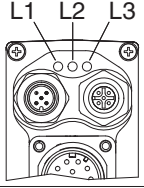
| FIELDBUS LEDS | NP Not Present | BC CANopen | BP PROFIBUS DP | EH EtherCAT | EW POWERLINK | EI EtherNet/IP |  |
|------------------|-------------------|-----------------|-------------------|----------------|-----------------|-------------------|-------------------------------------------------------------------------------------|
| L1 | | VALVE STATUS | | | LINK/ACT | | |
| L2 | | NETWORK STATUS | | | NETWORK STATUS | | |
| L3 | | SOLENOID STATUS | | | LINK/ACT | | |

5.2 Main connector signals - 12 pin A - see 13.1

| PIN | NP | Fieldbus | TECHNICAL SPECIFICATIONS | NOTES |
|-----|------------------------------------|----------|-------------------------------------------------------------------------------------------|------------------------------------------------------|
| 1 | V+ | | Power supply 24 Vdc (see 6.1) | Input - power supply |
| 2 | V0 | | Power supply 0 Vdc (see 6.1) | Gnd - power supply |
| 3 | ENABLE referred to: V0 VL0 | | Enable (24 Vdc) or disable (0 Vdc) the driver (see 6.8) | Input - on/off signal |
| 4 | Q_INPUT+ | | Flow reference input signal: ± 10 Vdc / ± 20 mA maximum range (see 6.2) | Input - analog signal Software selectable |
| 5 | INPUT- | | Negative reference input signal for Q_INPUT+ and F_INPUT+ | Input - analog signal |
| 6 | Q_MONITOR referred to: V0 VL0 | | Flow monitor output signal: ± 10 Vdc / ± 20 mA maximum range (see 6.4) | Output - analog signal Software selectable |
| 7 | F_INPUT+ | | Pressure/Force reference input signal: ± 10 Vdc / ± 20 mA maximum range (see 6.3) | Input - analog signal Software selectable |
| 8 | F_MONITOR referred to: V0 VL0 | | Pressure/Force monitor output signal: ± 10 Vdc / ± 20 mA maximum range (see 6.5) | Output - analog signal Software selectable |
| 9 | D_IN0 | | Multiple pressure/force PID selection, referred to V0 | Input - on/off signal |
| | | VL+ | Power supply 24 Vdc for driver's logic and communication | Input - power supply |
| 10 | D_IN1 | | Multiple pressure/force PID selection (not available for SF), referred to V0 | Input - on/off signal |
| | | VL0 (1) | Power supply 0 Vdc for driver's logic and communication | Gnd - power supply |
| 11 | FAULT referred to: V0 VL0 | | Fault (0 Vdc) or normal working (24 Vdc) (see 6.7) | Output - on/off signal |
| PE | EARTH | | Internally connected to driver housing | |

Note: (1) do not disconnect VL0 before VL+ when the driver is connected to PC USB port

5.3 Communications connectors B - C - see 12.2

| B USB connector - M12 - 5 pin always present | | |
|--------------------------------------------------------------------------------------------------------------------------------|---------|-----------------------------|
| PIN | SIGNAL | TECHNICAL SPECIFICATION (1) |
| 1 | +5V_USB | Power supply |
| 2 | ID | Identification |
| 3 | GND_USB | Signal zero data line |
| 4 | D- | Data line - |
| 5 | D+ | Data line + |

| C1 C2 BC fieldbus execution, connector - M12 - 5 pin | | |
|--------------------------------------------------------------------------------------------------------------------------------------------------------------------------------------------------------------------------|----------|---------------------------------------------------------------------------------------------------------------------------------------------------------------------------------------------------------|
| PIN | SIGNAL | TECHNICAL SPECIFICATION (1) |
| 1 | CAN_SHLD | Shield |
| 2 | not used | C1 - C2 pass-through connection (2) |
| 3 | CAN_GND | Signal zero data line |
| 4 | CAN_H | Bus line (high) |
| 5 | CAN_L | Bus line (low) |

| C1 C2 BP fieldbus execution, connector - M12 - 5 pin | | |
|--------------------------------------------------------------------------------------------------------------------------------------------------------------------------------------------------------------------------|--------|---------------------------------------|
| PIN | SIGNAL | TECHNICAL SPECIFICATION (1) |
| 1 | +5V | Termination supply signal |
| 2 | LINE-A | Bus line (high) |
| 3 | DGND | Data line and termination signal zero |
| 4 | LINE-B | Bus line (low) |
| 5 | SHIELD | |

| C1 C2 EH, EW, EI fieldbus execution, connector - M12 - 4 pin | | |
|----------------------------------------------------------------------------------------------------------------------------------------------------------------------------------------------------------------------------------|--------|-----------------------------|
| PIN | SIGNAL | TECHNICAL SPECIFICATION (1) |
| 1 | TX+ | Transmitter |
| 2 | RX+ | Receiver |
| 3 | TX- | Transmitter |
| 4 | RX- | Receiver |
| Housing | SHIELD | |

Notes: (1) shield connection on connector's housing is recommended

(2): pin 2 can be fed with external +5V supply of CAN interface

5.4 Remote pressure/force transducer connector - M12 - 5 pin D - see 12.3

| PIN | SIGNAL | TECHNICAL SPECIFICATION | NOTES | D1 SP, SL - Single transducer (1) | | D2 SF - Double transducers (1) | |
|-----|---------|--------------------------------------------------------------------|-----------------------------------------------------|---------------------------------------------------------------------------------------------------------------------|---------|------------------------------------------------------------------------------------------------------------------|---------|
| | | | | Voltage | Current | Voltage | Current |
| 1 | VF +24V | Power supply +24Vdc | Output - power supply | Connect | Connect | Connect | Connect |
| 2 | TR1 | 1st signal transducer: ± 10 Vdc / ± 20 mA maximum range | Input - analog signal Software selectable | Connect | Connect | Connect | Connect |
| 3 | AGND | Common gnd for transducer power and signals | Common gnd | Connect | / | Connect | / |
| 4 | TR2 | 2nd signal transducer: ± 10 Vdc / ± 20 mA maximum range | Input - analog signal Software selectable | / | / | Connect | Connect |
| 5 | NC | Not connect | | / | / | / | / |

Note: (1) single/double transducer configuration is software selectable - see 6.9

Remote pressure transducers connection - example

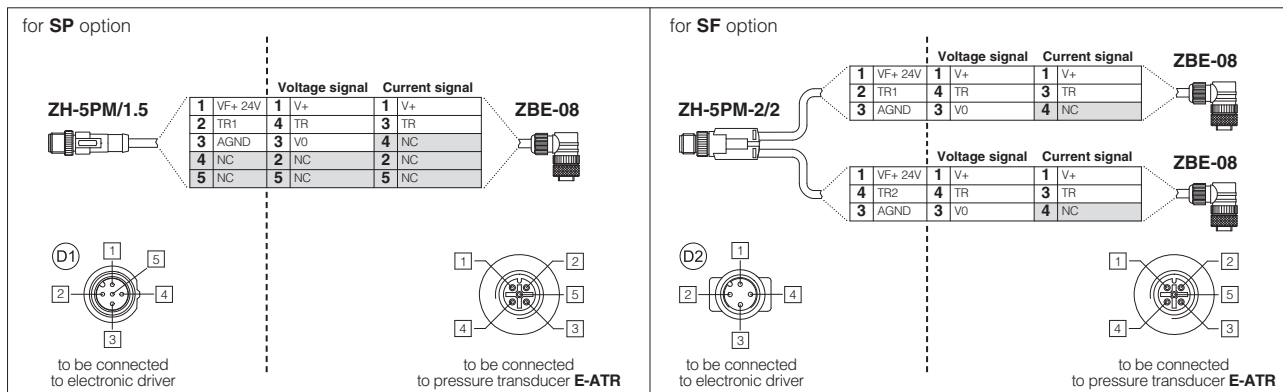

6 SIGNALS SPECIFICATIONS

Atos digital drivers are CE marked according to the applicable directives (e.g. Immunity/Emission EMC Directive).

Installation, wirings and start-up procedures must be performed according to the prescriptions shown in tech table **F003** and in the user manuals included in the E-SW programming software.

The electrical signals of the driver (e.g. monitor signals) must not be directly used to activate safety functions, like to switch-ON/OFF the machine's safety components, as prescribed by the European standards.

6.1 Power supply (V+ and V0)

The power supply must be appropriately stabilized or rectified and filtered: apply at least a 10000 μ F/40 V capacitance to single phase rectifiers or a 4700 μ F/40 V capacitance to three phase rectifiers.

In case of double power supply see 6.6.

A safety fuse is required in series to each power supply: 2,5 A time lag fuse.

6.2 Flow reference input signals (Q_INPUT+)

The driver is designed to receive an analog reference input signal for the valve's spool position.

Reference input signal is factory preset according to selected valve code, defaults are ± 10 Vdc for standard and $4 \div 20$ mA for /I option.

Input signal can be reconfigured via software selecting between voltage and current, within a maximum range of ± 10 Vdc or ± 20 mA.

Drivers with fieldbus interface can be software set to receive reference signal directly by the machine control unit (fieldbus reference).

Analog reference input signal can be used as on-off commands with input range $0 \div 24$ Vdc.

6.3 Pressure or force reference input signal (F_INPUT+)

Functionality of F_INPUT+ signal (pin 7), is used as reference for the driver pressure/force closed loop (see section [2](#)).

Reference input signal is factory preset according to selected valve code, defaults are ± 10 Vdc for standard and $4 \div 20$ mA for /I option.

Input signal can be reconfigured via software selecting between voltage and current, within a maximum range of ± 10 Vdc or ± 20 mA.

Drivers with fieldbus interface can be software set to receive reference signal directly by the machine control unit (fieldbus reference).

Analog reference input signal can be used as on-off commands with input range $0 \div 24$ Vdc.

6.4 Flow monitor output signal (Q_MONITOR)

The driver generates an analog output signal proportional to the actual spool position; the monitor output signal can be software set to show other signals available in the driver (e.g. analog reference, fieldbus reference, valve spool position).

Monitor output signal is factory preset according to selected valve code, defaults are ± 10 Vdc for standard and $4 \div 20$ mA for /I option.

Output signal can be reconfigured via software selecting between voltage and current, within a maximum range of ± 10 Vdc or ± 20 mA.

6.5 Pressure or force monitor output signal (F_MONITOR)

The driver generates an analog output signal proportional to alternated pressure/force control; the monitor output signal can be software set to show other signals available in the driver (e.g. analog reference, force reference).

Monitor output signal is factory preset according to selected valve code, defaults are ± 10 Vdc for standard and $4 \div 20$ mA for /I option.

Output signal can be reconfigured via software selecting between voltage and current, within a maximum range of ± 10 Vdc or ± 20 mA.

6.6 Power supply for driver's logic and communication (VL+ and VL0)

The power supply for driver's logic and communication must be appropriately stabilized or rectified and filtered: apply at least a 10000 μ F/40 V capacitance to single phase rectifiers or a 4700 μ F/40 V capacitance to three phase rectifiers.

The separate power supply for driver's logic on pin 9 and 10, allow to remove solenoid power supply from pin 1 and 2 maintaining active the diagnostics, USB and fieldbus communications.

A safety fuse is required in series to each driver's logic and communication power supply: 500 mA fast fuse.

6.7 Fault output signal (FAULT)

Fault output signal indicates fault conditions of the driver (solenoid short circuits/not connected, reference or transducer signal cable broken, maximum error exceeded, etc.). Fault presence corresponds to 0 Vdc, normal working corresponds to 24 Vdc.

Fault status is not affected by the status of the Enable input signal.

Fault output signal can be used as digital output by software selection.

6.8 Enable input signal (ENABLE)

To enable the driver, supply 24 Vdc on pin 3: Enable input signal allows to enable/disable the current supply to the solenoid, without removing the electrical power supply to the driver; it is used to active the communication and the other driver functions when the valve must be disabled for safety reasons. This condition does not comply with European Norms EN13849-1 (ex EN954-1).

Enable input signal can be used as digital input by software selection.

6.9 Remote pressure/force transducer input signal

Analog remote pressure transducers or load cell can be directly connected to the driver.

Analog input signal is factory preset according to selected valve code, defaults are ± 10 Vdc for standard and $4 \div 20$ mA for /C option.

Input signal can be reconfigured via software selecting between voltage and current, within a maximum range of ± 10 Vdc or ± 20 mA.

Refer to pressure/force transducer characteristics to select the transducer type according to specific application requirements (see section [8](#)).

6.10 Multiple PID selection (D_IN0 and D_IN1) - only for NP execution

Two on-off input signals are available on the main connector to select one of the four pressure (force) PID parameters setting, stored into the driver.

Switching the active setting of pressure PID during the machine cycle allows to optimize the system dynamic response in different hydraulic working conditions (volume, flow, etc.).

Supply a 24 Vdc or a 0 Vdc on pin 9 and/or pin 10, to select one of the PID settings as indicated by binary code table at side. Gray code can be selected by software.

| PID SET SELECTION | | | | |
|-------------------|-------|--------|--------|--------|
| PIN | SET 1 | SET 2 | SET 3 | SET 4 |
| 9 | 0 | 24 Vdc | 0 | 24 Vdc |
| 10 | 0 | 0 | 24 Vdc | 24 Vdc |

7 IN / OUT FIELDBUS COMMUNICATION CONNECTORS

Two fieldbus communication connectors are always available for digital drivers executions BC, BP, EH, EW, EI. This features allows considerable technical advantages in terms of installation simplicity, wirings reduction and also avoid the usage expensive T-connectors.

For BC and BP executions the fieldbus connectors have an internal pass-through connection and can be used like end point of the fieldbus network, using an external terminator (see tech table **GS500**).

For EH, EW and EI execution the external terminators are not required: each connector is internally terminated.

BC and BP pass-through connection

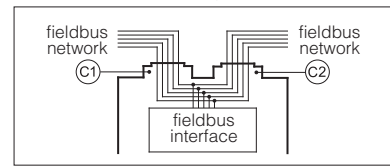

8 PRESSURE/FORCE TRANSDUCER CHARACTERISTICS

The accuracy of the pressure/force control is strongly dependent to the selected pressure/force transducer (see section 5). Alternated pressure/force controls require to install pressure transducers or load cell to measure the actual pressure/force values.

Pressure transducers allow easy system integration and cost effective solution for both alternated pressure and force controls (see tech table **GS465** for pressure transducers details). Load cell transducers allow the user to get high accuracy and precise regulations for alternated force control.

The characteristics of the remote pressure/force transducers must be always selected to match the application requirements and to obtain the best performances: transducer nominal range should be at least 115%÷120% of the maximum regulated pressure/force.

9 PROGRAMMING TOOLS - see tech table **GS500**

Valve's functional parameters and configurations, can be easily set and optimized using Atos E-SW programming software connected via USB port to the digital driver. For fieldbus versions, the software permits valve's parameterization through USB port also if the driver is connected to the central machine unit via fieldbus.

The software is available in different versions according to the driver's options:

| | | | | |
|----------------------|----------|----------------------------------------------------------------|------------------|---------------|
| E-SW-BASIC | support: | NP (USB) | PS (Serial) | IR (Infrared) |
| E-SW-FIELDBUS | support: | BC (CANopen) | BP (PROFIBUS DP) | EH (EtherCAT) |
| | | EW (POWERLINK) | EI (EtherNet/IP) | |
| E-SW-*/PQ | support: | valves with SP, SF, SL alternated control (e.g. E-SW-BASIC/PQ) | | |

WARNING: drivers USB port is not isolated!

The use of isolator adapter is highly recommended for PC protection (see table **GS500**)

Free programming software, web download:

E-SW-BASIC web download = software can be downloaded upon web registration at www.download.atos.com ; service and DVD not included
Upon web registration user receive via email the Activation Code (software free license) and login data to access Atos Download Area

DVD programming software, to be ordered separately:

E-SW-*/PQ DVD first supply = software has to be activated via web registration at www.download.atos.com ; 1 year service included
Upon web registration user receive via email the Activation Code (software license) and login data to access Atos Download Area

E-SW-*/N/PQ DVD next supplies = only for supplies after the first; service not included, web registration not allowed
Software has to be activated with Activation Code received upon first supply web registration

Atos Download Area: direct access to latest releases of E-SW software, manuals, USB drivers and fieldbus configuration files at www.download.atos.com

USB Adapters, Cables and Terminators, can be ordered separately

USB connection

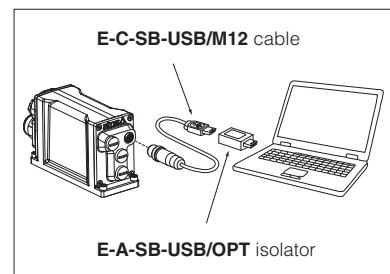

10 MAIN SOFTWARE PARAMETER SETTINGS

The following is a brief description of the main settings and features of digital drivers with alternated P/Q control. For a detailed descriptions of available settings, wirings and installation procedures, please refer to the user manual included in the E-SW programming software:

E-MAN-RI-LES-S - user manual for **TES-S** and **LES-S** digital drivers

10.1 Scale

Scale function allows to set the maximum valve opening at maximum reference signal value.

This regulation allows to reduce the maximum valve regulation in front of maximum reference signal.

Two different Scale regulations are available for double solenoid valves or three position single solenoid valves: ScaleA for positive and ScaleB for negative reference signal.

10.2 Bias and Threshold

Proportional valves may be provided with a dead band in the hydraulic regulation corresponding to their switch-off status.

This dead band discontinuity in the valve's regulation can be compensated by activating the Bias function, which adds a fixed preset Bias value to the reference signal (analog or fieldbus external input).

The Bias function is activated when the reference signal overcome the Threshold value, preset into the driver.

The Bias setting allows to calibrate the Bias valve opening to the specific proportional valve to which the driver is coupled.

The Threshold setting is useful to avoid undesired valve regulation at zero reference signal when electric noise is present on the analog input signal: smaller threshold reduces the reference signal dead band, greater values are less affected by electric noise presence.

If fieldbus reference signal is active, threshold should be set to zero.

Two different Bias regulations are available for double solenoid valves: positive reference signals activate BiasA and negative reference signals activate BiasB.

Refer to the programming manuals for a detailed description of other software selectable Bias functions.

10.3 Offset

Proportional valves may be provided with zero overlapping in the hydraulic regulation corresponding to zero reference input signal (valve's central spool position).

The Offset function allows to calibrate the valve's spool central position to the specific hydraulic system setup (e.g. valve applied to cylinder with differential areas). Offset default setting is zero.

10.1, 10.2 - Scale, Bias & Threshold

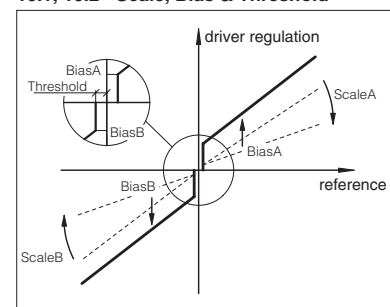

10.3 - Offset

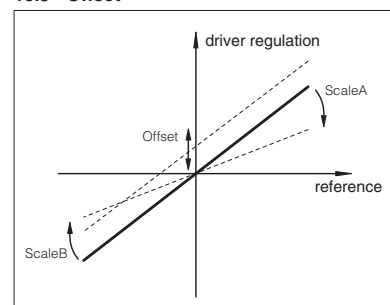

10.4 Ramps

The ramp generator allows to convert sudden change of electronic reference signal into smooth time-dependent increasing/decreasing of the valve opening.

Different ramp mode can be set:

- single ramp for any reference variation
- two ramps for increasing and for decreasing reference variations
- four ramps for positive/negative signal values and increasing/decreasing reference variations

Ramp generator is useful for application where smooth hydraulic actuation is necessary to avoid machine vibration and shocks.

If the proportional valve is driven by a closed loop driver, the ramps can lead to unstable behaviour, for these applications ramp function can be software disabled (default setting).

10.4 - Ramps

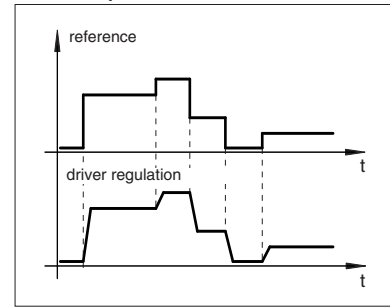

10.5 Linearization

Linearization function allows to set the relation between the reference input signal and the controlled valve's regulation.

Linearization is useful for applications where it is required to linearize the valve's regulation in a defined working condition.

10.6 Dither

The dither is an high frequency modulation added to the valve's reference signal to reduce the hysteresis of the valve's regulation; in fact a small vibration in the valve's hydraulic regulation considerably reduces the mechanical friction effects (e.g. due to cylinder seals).

Dither frequency and amplitude are software selectable; the amplitude is automatically reduced at high reference values (high regulated flow / cylinder speed) to avoid possible instability.

Lower frequency and higher amplitude reduce hysteresis but also reduce the regulation stability. In some application this can lead to vibration and noise: right setting usually depends on system setup. Dither default setting is disabled.

10.5 - Linearization

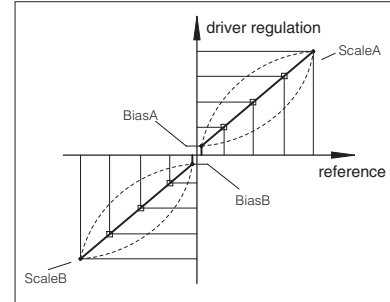

11 OVERALL DIMENSIONS [mm]

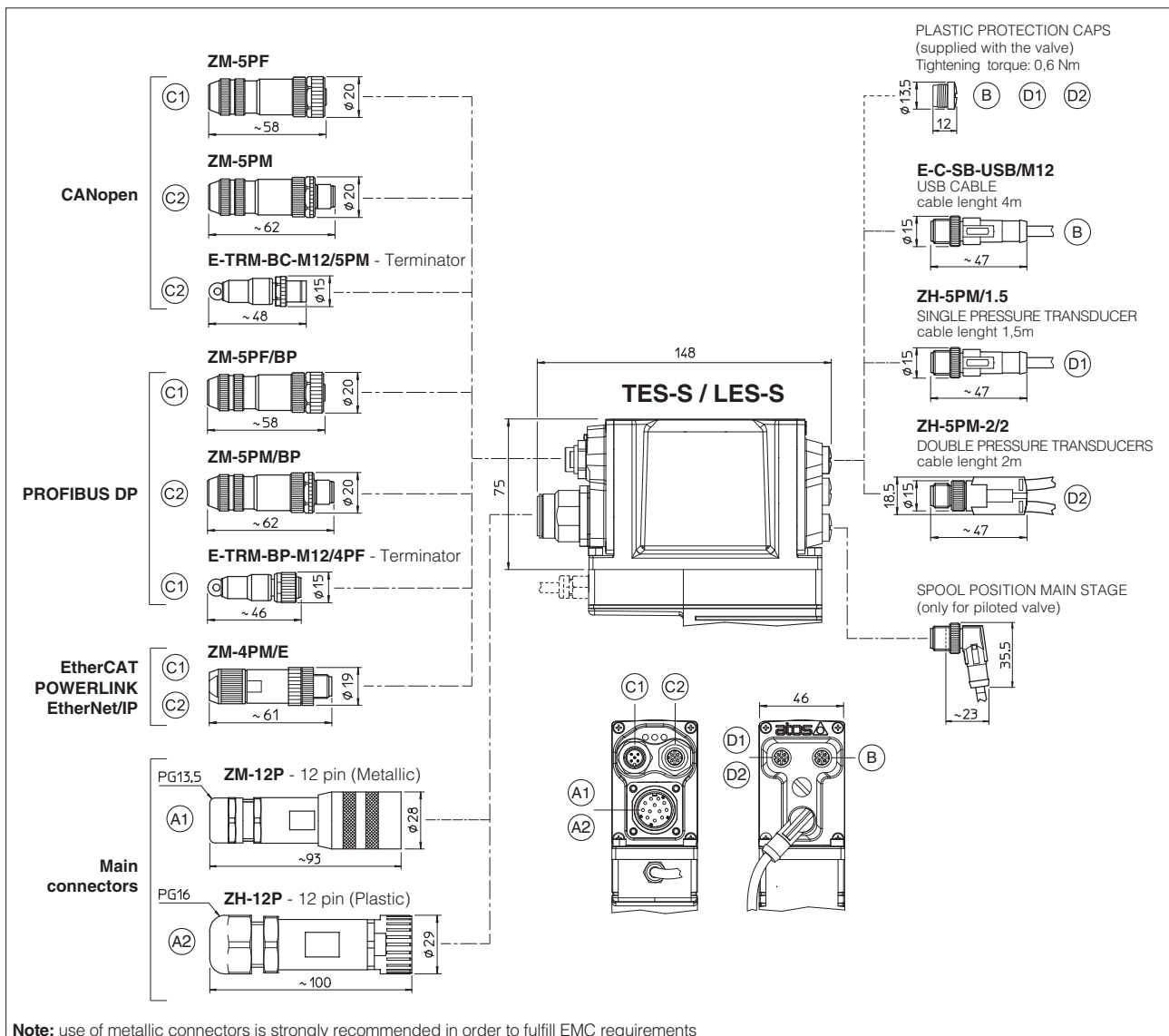

12 CONNECTORS CHARACTERISTICS - to be ordered separately

12.1 Main connectors - 12 pin

| CONNECTOR TYPE | POWER SUPPLY | POWER SUPPLY |
|-----------------------|---------------------------------------------------------------------|-------------------------------------------------------------------------------------------------------------------------------------------|
| CODE | (A1) ZM-12P | (A2) ZH-12P |
| Type | 12pin female straight circular | 12pin female straight circular |
| Standard | DIN 43651 | DIN 43651 |
| Material | Metallic | Plastic reinforced with fiber glass |
| Cable gland | PG13,5 | PG16 |
| Recommended cable | LiYCY 12 x 0,75 mm ² max 20 m (logic and power supply) | LiYCY 10 x 0,14mm ² max 40 m (logic) LiYY 3 x 1mm ² max 40 m (power supply) |
| Conductor size | 0,5 mm ² to 1,5 mm ² - available for 12 wires | 0,14 mm ² to 0,5 mm ² - available for 9 wires 0,5 mm ² to 1,5 mm ² - available for 3 wires |
| Connection type | to crimp | to crimp |
| Protection (EN 60529) | IP 67 | IP 67 |

12.2 Fieldbus communication connectors

| CONNECTOR TYPE | BC CANopen (1) | | BP PROFIBUS DP (1) | | EH EtherCAT, EW POWERLINK, EI EtherNet/IP (2) |
|-----------------------|--------------------------------------|------------------------------|--------------------------------------|------------------------------|-----------------------------------------------|
| CODE | (C1) ZM-5PF | (C2) ZM-5PM | (C1) ZM-5PF/BP | (C2) ZM-5PM/BP | (C1) (C2) ZM-4PM/E |
| Type | 5 pin female straight circular | 5 pin male straight circular | 5 pin female straight circular | 5 pin male straight circular | 4 pin male straight circular |
| Standard | M12 coding A – IEC 61076-2-101 | | M12 coding B – IEC 61076-2-101 | | M12 coding D – IEC 61076-2-101 |
| Material | Metallic | | Metallic | | Metallic |
| Cable gland | Pressure nut - cable diameter 6÷8 mm | | Pressure nut - cable diameter 6÷8 mm | | Pressure nut - cable diameter 4÷8 mm |
| Cable | CANbus Standard (DR 303-1) | | PROFIBUS DP Standard | | Ethernet standard CAT-5 |
| Connection type | screw terminal | | screw terminal | | terminal block |
| Protection (EN 60529) | IP 67 | | IP 67 | | IP 67 |

Notes: (1) E-TRM-** terminators can be ordered separately - see tech table **GS500**

(2) internally terminated

12.3 Remote pressure/force transducers connectors

| CONNECTOR TYPE | SP, SL - Single transducer | SF - Double transducers |
|-----------------------|------------------------------------------|----------------------------------------|
| CODE | (D1) ZH-5PM/1.5 | (D2) ZH-5PM-2/2 |
| Type | 5 pin male straight circular | 4 pin male straight circular |
| Standard | M12 coding A – IEC 61076-2-101 | M12 coding A – IEC 61076-2-101 |
| Material | Plastic | Plastic |
| Cable gland | Connector moulded on cables 1,5 m length | Connector moulded on cables 2 m length |
| Cable | 5 x 0,25 mm ² | 3 x 0,25 mm ² (both cables) |
| Connection type | molded cable | splitting cable |
| Protection (EN 60529) | IP 67 | IP 67 |

13 MODEL CODE FOR SPARE PARTS

Integral drivers are available as spare parts only for Atos authorized service centers.

| | | | | | | | | | | | | | | |
|-----------------------------------------------------------------------------------------------------------------------------------------------------|---|----------|--|-----------|---|----------|---|-----------|---|------------------------------------------------------------------------------------------------------------------------------------------------------------------------------------------------------|---|--------------------------------------------------------------------------|---|----------|
| E-RI | - | T | | ES | - | S | - | NP | - | 01H | / | * | / | * |
| Integral electronic driver T = closed-loop one LVDT transducer L = closed-loop two LVDT transducers ES = full | | | | | | | | | | | | Set code (1) Series number | | |
| | | | | | | | | | | 01H = for single solenoid proportional valves 05H = for double solenoid proportional valves (only TES-S) | | | | |
| | | | | | | | | | | Fieldbus interface , USB port always present: NP = Not Present EH = EtherCAT BC = CANopen EW = POWERLINK BP = PROFIBUS DP EI = EtherNet/IP | | | | |
| | | | | | | | | | | Alternated P/Q control , see section [2] : S = closed loop pressure/force (software selectable) | | | | |

(1) set code identifies the correspondance between the integral driver and the relevant valve; it is assigned by Atos when the driver is ordered as spare part