

Mounting subplates type BA-214/*-AL

multi-station, for valves ISO 4401 size 06, in aluminium

The multi-stations subplates type BA-214/*-AL for directional control valves are in aluminium and their mounting surface are in accordance with the international standards ISO 4401.

They perform limited pressure drop and are made by a **single subplate** from 1 to 7 stations for directional valves and modular elements ISO 4401 size 06.

Main characteristics:

P and T ports = G 1/2; A and B lateral use ports G 3/8; M pressure gauge connection G1/4; $Q_{max} = 80$ l/min; Q_{max} use ports = 60 l/min; $P_{max} = 250$ bar

Note: for versions /M and /MH $Q_{max} = 35$ l/min;

For other technical characteristics, see section 2 and 3.

1 MODEL CODE OF SUBPLATES TYPE BA-214/*-AL

BA-214	/	5	/	MH	/	210	-	AL	*	PE
Type of subplate: BA-214 = for valves ISO size 06 On request, available with rear ports A and B								Series number		Seals material: only for M, MH - = HNBR PE = HNBR
Number of stations: 1 = one station 2 = two stations 3 = three stations 4 = four stations 5 = five stations 6 = six stations 7 = seven stations								AL = in aluminium On request, available with anodizing		
						Pressure range of pressure relief valve, for versions /M and /MH: 100 = 100 bar 210 = 210 bar 250 = 250 bar				
						M = with direct operated pressure relief cartridge CART M-5/** - see tab. C010 (available also as spare part)				
						MH = with pressure relief valve type CART M-5, arranged with venting solenoid valve				

2 TECHNICAL CHARACTERISTICS

Installation position	Any position.
Operating pressure	Ports P, T, A, B = 250 bar See technical table of the valves to be assembled
Ambient temperature range	-30°C ÷ +70°C
Fluid	Hydraulic oil as per DIN 51524...535, for other fluids contact our technical office
Recommended viscosity	15 ÷ 100 mm ² /s - max allowed range: see the technical table of the valves to be assembled
Max fluid contamination level	See technical table of the valves to be assembled and filter section at www.atos.com or KTF catalog
Fluid temperature	See technical table of the valves to be assembled
Compliance	RoHS Directive 2011/65/EU as last update by 2015/65/EU REACH Regulation (EC) n°1907/2006

3 REGULATED PRESSURE/FLOW DIAGRAM FOR VERSIONS /M and /MH

MAIN CHARACTERISTICS OF ENCLOSED PRESSURE RELIEF VALVE	
Model code	Regulation range
CART M-5/100	3 ÷ 100 bar
CART M-5/210	5 ÷ 210 bar
CART M-5/250	7 ÷ 250 bar
$Q_{max} = 35$ l/min	

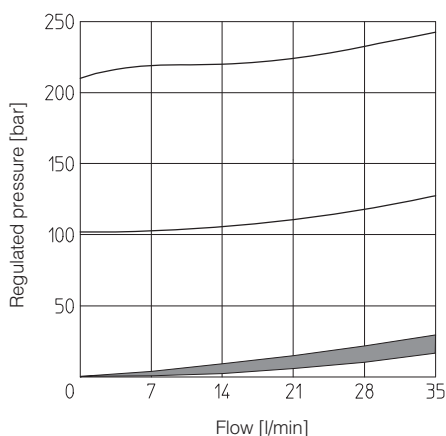

4 INSTALLATION DIMENSIONS OF CART M-5/**

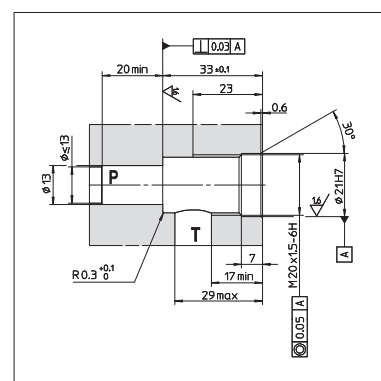

5 OVERALL DIMENSIONS OF SUBPLATES TYPE BA-214/*-AL [mm]

Hydraulic scheme

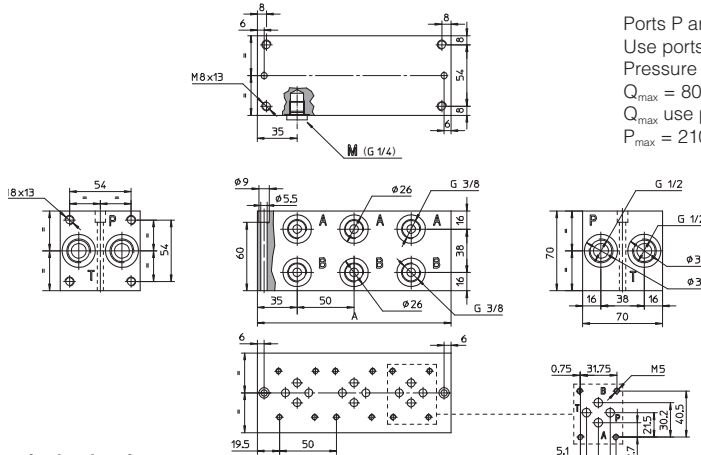
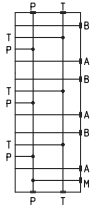

Ports P and T = G 1/2
 Use ports A and B = G 3/8
 Pressure gauge port M = G 1/4 (plugged)
 $Q_{max} = 80$ l/min
 Q_{max} use ports = 60 l/min
 $P_{max} = 210$ bar

The 3-stations subplate is shown in the drawing

The length of the subplate varies with the number of stations as shown in the table below

Stations	1	2	3	4	5	6	7
Dimension A	70	120	170	220	270	320	370
Mass [Kg]	1	1,4	2	2,6	3,2	3,8	4,4

Mounting surface
 ISO 4401-03-02-0-05

6 OVERALL DIMENSIONS OF SUBPLATES TYPE BA-214/*M/*-AL [mm]

Hydraulic scheme

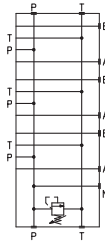

Pressure relief cartridge
 CART M5 (see tab. C010)

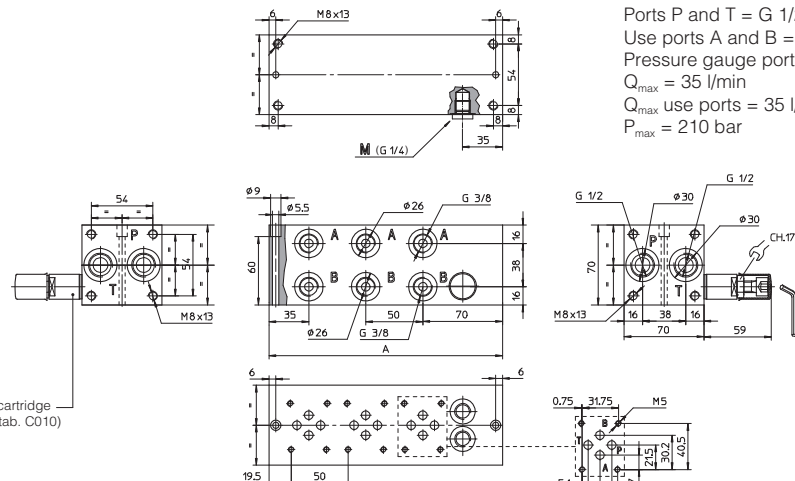

Ports P and T = G 1/2
 Use ports A and B = G 3/8
 Pressure gauge port M = G 1/4 (plugged)
 $Q_{max} = 35$ l/min
 Q_{max} use ports = 35 l/min
 $P_{max} = 210$ bar

The 3-stations subplate is shown in the drawing

The length of the subplate varies with the number of stations as shown in the table below

Stations	1	2	3	4	5	6	7
Dimension A	105	155	205	255	305	355	405
Mass [Kg]	1,1	1,5	2,1	2,7	3,3	3,9	4,5

Mounting surface
 ISO 4401-03-02-0-05

7 OVERALL DIMENSIONS OF SUBPLATES TYPE BA-214/*MH/*-AL [mm]

Hydraulic scheme

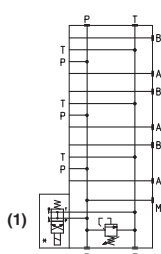

Pressure relief cartridge
 CART M5 (see tab. C010)

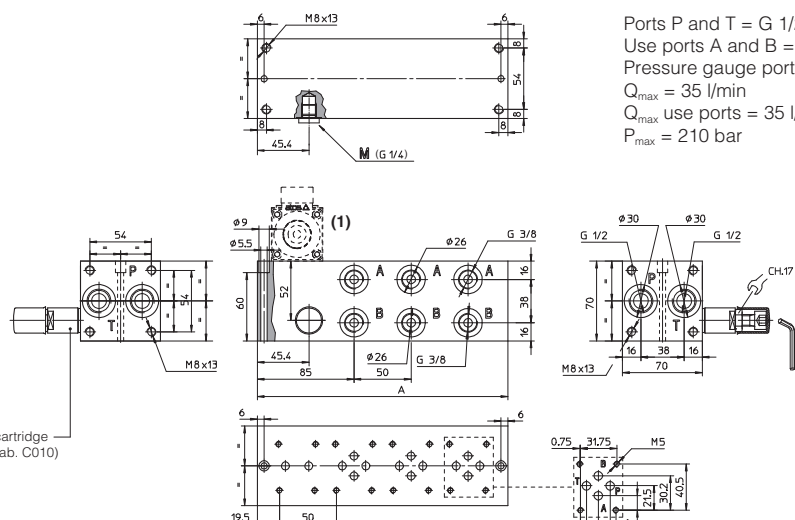

Ports P and T = G 1/2
 Use ports A and B = G 3/8
 Pressure gauge port M = G 1/4 (plugged)
 $Q_{max} = 35$ l/min
 Q_{max} use ports = 35 l/min
 $P_{max} = 210$ bar

The 3-stations subplate is shown in the drawing

The length of the subplate varies with the number of stations as shown in the table below

Stations	1	2	3	4	5	6	7
Dimension A	120	170	220	270	320	370	420
Mass [Kg]	1,2	1,6	2,2	2,8	3,4	4	4,6

Mounting surface
 ISO 4401-03-02-0-05

(1) The venting directional valve in the dashed line must be ordered separately