

Complementary safety valves with /FC mechanical microswitches

conforming to Machine Directive 2006/42/CE

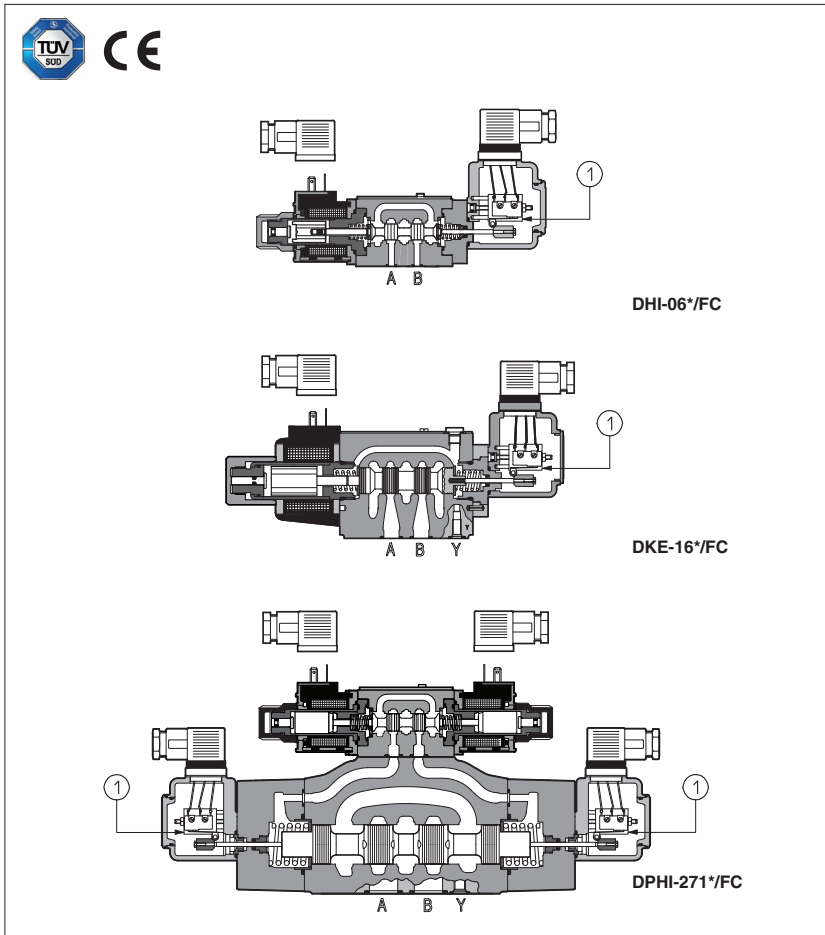

These valves are provided with **FC** mechanical microswitch ① for the spool position monitor and they are designed to fulfil the safety criteria imposed to machine manufacturers by the European Machine Directive.

In addition to the normal function they supplies an electrical on-off output signal indicating the position of the spool/pop-pet of the valve.

The safety function performed by the valve is to cut off the hydraulic power line in case of emergency condition, avoiding dangerous movements of the machines actuators. The spool position signal informs the machine controller about the "open" or "intercepted" status of the hydraulic line.

These valves are available in direct and piloted execution and they keep the same hydraulic and electric characteristics of standard products from which they are derived.

Classic example of application: on presses or on blow moulding machines the safety valves are used to shut off the fluid energy to one or more actuators as a consequence of the opening of a mechanical safety device ("gate") or as a consequence of an "emergency stop" command.

The components shown on this technical table are CE marked and certified by TÜV, in accordance with the technical safety requirements provided in the **Machine Directive 2006/42/CE** but not included in the safety components of annex IV.

For details about the applicable EN standards, see www.atos.com, catalog on line page, section P, table P004.

① MODEL CODE OF DIRECTIONAL CONTROL SAFETY SOLENOID VALVES

DHI	-	0	63	1/2	/	A	FC	-	X	24DC	**	/*
<p>Type of solenoid valve DHI = direct, size 06 (see tab. E010) DKE = direct, size 10 (see tab E025) DPHI, DPHE = piloted, size 16 and 25 (see tab. E085)</p> <p>Size ISO 4401 0 = size 06 (DHI, DHU) 1 = size 10 (DKE, DKER) 2 = size 16 (DPH*) 3 = size 25 (DPH*)</p> <p>Valve configuration, see section ② 61 = single solenoid, central plus external position, spring centered 63 = single solenoid, 2 external positions, spring offset 67 = single solenoid, external plus central position, spring offset 71 = double solenoid, 3 positions, spring centered (only DPH*) 75 = double solenoid, 2 external positions, with detent (only DPH*)</p> <p>Spool type, see section ②</p> <p>Options (WP not available for safety valves)</p>												
<p>Seals material - = NBR PE = FKM</p> <p>Series number</p> <p>Voltage code, see section ④</p> <p>X = without solenoid connector, to be order separately (see tab. K500)</p> <p>Type of switch: FC = mechanical microswitch (DH* and DKE* are available only in single solenoid version) Both normally open and normally closed contacts are available on the connector.</p>												

2 CONFIGURATIONS and SPOOLS

Configurations

Spools

1 0 2	1 0 2	1 0 2	1 0 2
0	1	2	3
4	5	6	7
8	90	09	91
19	93	39	94
49	16	17	58
1/9	1/3	2/7	5/7
6/7	7/7	(1) only for DK*-1611/3*Y DC (2) only for DHI-061* and DK*-163* not available version /A	

Configurations

Spools

1 0 2	1 0 2	1 0 2	1 0 2
0	1	2	3
4	5	6	7
8	90	09	91
19	93	39	94
49	16	17	58

3 VOLTAGE CODE

Valve	External supply nominal voltage ± 10%	Voltage code	Type of connector	Power consumption
DHI DPHI	6 DC	6 DC	666 or 667	33 W
	9 DC	9 DC		
	12 DC	12 DC		
	14 DC	14 DC		
	18 DC	18 DC		
	24 DC	24 DC		
	28 DC	28 DC		
	48 DC	48 DC		
	110 DC	110 DC		
	125 DC	125 DC		
	220 DC	220 DC		
	24/50 AC	24/50/60 AC		
	24/60 AC	24/50/60 AC		
	48/50 AC	48/50/60 AC		
	48/60 AC	48/50/60 AC		
	110/50 AC	110/50/60 AC		
120/60 AC	120/60 AC			
230/50 AC	230/50/60 AC			
230/60 AC	230/60 AC			
110/50 AC	110RC	669	40 VA	
120/60 AC	110RC		35 VA	
230/50 AC	230RC	669	40 VA	
230/60 AC	230RC		35 VA	

Valve	External supply nominal voltage ± 10%	Voltage code	Type of connector	Power consumption		
DPHE	12 DC	12 DC	666 or 667	30 W		
	14 DC	14 DC				
	24 DC	24 DC				
	28 DC	28 DC				
	48 DC	48 DC				
	110 DC	110 DC				
	125 DC	125 DC				
	220 DC	220 DC				
	110/50 AC	110/50/60 AC				
	230/50 AC	230/50/60 AC				
	115/60 AC	115/60 AC				
	230/60 AC	230/60 AC				
	110/50 AC	110 RC			669	58 VA
	120/60 AC	110 RC				
	230/50 AC	230 RC				
	230/60 AC	230 RC				
DKE	12 DC	12 DC	666 or 667	36 W		
	24 DC	24 DC				
	110 DC	110 DC				
	220 DC	220 DC				
	110/50/60 AC	110/50/60 AC		669	85 VA	
	230/50/60 AC	230/50/60 AC				
	110/50/60 AC	110 DC				
	230/50/60 AC	220 DC				

4 TECHNICAL CHARACTERISTICS OF MECHANICAL MICROSWITCHES

MECHANICAL MICROSWITCHES (/FC)				
		With resistive load		With inductive load
		Max switching power	AC	125 V
250 V	5 A			5 A
DC	30 V		5 A	3 A
	50 V		1 A	1 A
	125 V		0,5 A	0,03 A
	250V		0,25 A	0,03 A
Mechanical life	Min 100 millions cycles			

5 CONNECTING SCHEME OF MECHANICAL MICROSWITCHES

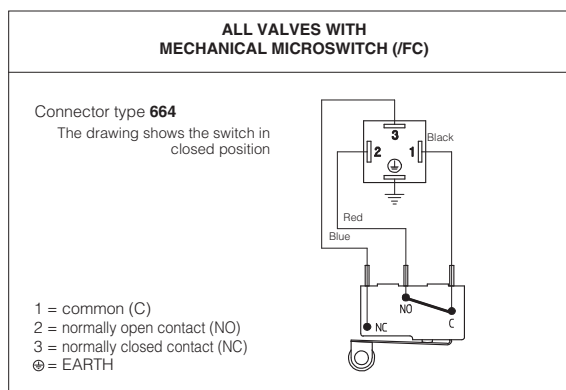

6 MAIN CHARACTERISTICS

Installation position	Any position	
Subplate surface finishing	Roughness index Ra 0,4 - flatness ratio 0,01/100 (ISO 1101)	
Ambient temperature	from -20°C to +70°C	
Fluid	Hydraulic oil as per DIN 51524 535; for other fluids see section 1	
Recommended viscosity	15 ÷ 100 mm ² /s at 40°C (ISO VG 15 ÷ 100)	
Fluid contamination class	ISO 4406 class 21/19/16 NAS 1638 class 10, in line filters of 25 µm (β ₁₀ ≥ 75 recommended)	
Fluid temperature	-20°C +60°C (standard seals) -20°C +80°C (/PE seals)	
Flow direction	As shown in the symbols of tables 2	
Operating pressure	DHI	P, A, B = 350 bar T = 20 bar
	DKE	P, A, B = 350 bar T = (with Y port not connected to tank) 20 bar T = (with Y port drained to tank) 250 bar
	DPH*	P, A, B, X = 350 bar T = 250 bar for external drain (standard) T and Y with internal drain (option /D) = 120 bar DPHI; 210 bar DPHE (DC); 160 bar DPHE (AC) Ports Y (if required): 0 bar Minimum pilot pressure for correct operation is 8 bar
Maximum flow	DHI	60 l/min see technical table E010, section 8, operating limits
	DKE	150 l/min see technical table E025, section 9, operating limits
	DPH*	DPH*-2: 300 l/min ; DPH*-3: 700 l/min ;

6.1 Coils characteristics

Insulation class	H (180°C) for all valves with DC coils and DHI, DPHI with AC coils F (155°C) for DKE, DPHE with AC coils Due to the occurring surface temperatures of the solenoid coils, the European standards EN ISO 13732-1 EN ISO 4413 must be taken into account
Connector protection degree	IP 65
Relative duty factor	100%
Supply voltage and frequency	See electric feature 6
Supply voltage tolerance	± 10%
Certification (only DHI, DKER, DPHI)	cURus North American standard

WARNING: the inobservance of following prescriptions invalidates the certification and may represent a risk for personnel injury
Safety valves must be installed and commissioned only by qualified personnel
Safety valves must not be disassembled
The inductive proximity switch or the position switch can be adjusted only by the manufacturer
Valve's components cannot be interchanged
The valves must operate without switching shocks and spool / poppet vibrations



7 DHI-*/FC DIMENSIONS [mm]

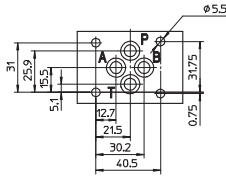

ISO 4401: 2005
Mounting surface: 4401-03-02-0-05
 Fastening bolts:
 4 socket head screws M5x50 class 12.9
 Tightening torque = 8 Nm
 Seals: 4 OR 108
 Ports P,A,B,T: $\varnothing = 7.5$ mm (max).

P = PRESSURE PORT
A, B = USE PORT
T = TANK PORT
 For the max pressures on ports, see section 4

DHI-*/FC (DC, AC)

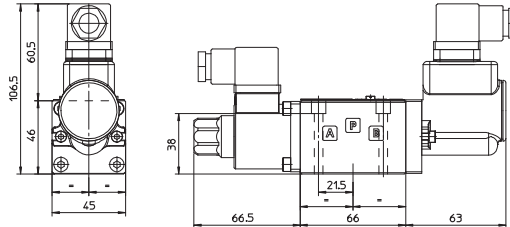

Mass: kg 1,6

8 DKE-*/FC DIMENSIONS [mm]

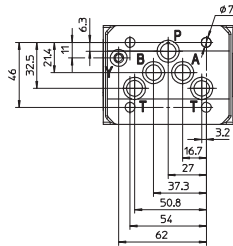

ISO 4401: 2005
Mounting surface: 4401-05-05-0-05
(without port X)
 Fastening bolts:
 4 socket head screws M6x40 class 12.9
 Tightening torque = 15 Nm
 Seals: 5 OR 2050. 1 OR 108
 Ports P,A,B,T: $\varnothing = 11.5$ mm (max)
 Ports Y: $\varnothing = 5$ mm

P = PRESSURE PORT
A, B = USE PORT
T = TANK PORT
Y = DRAIN PORT
 For the max pressures on ports, see section 4

DKE/FC-DC

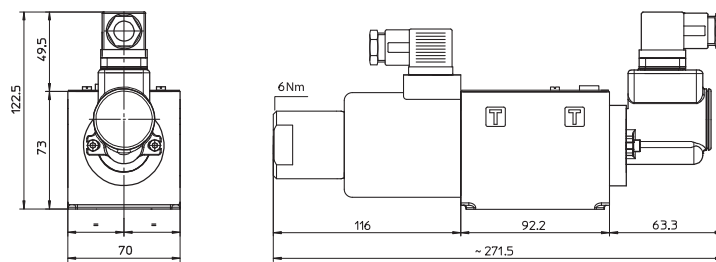

Mass: kg 4,3

DKE/FC-AC

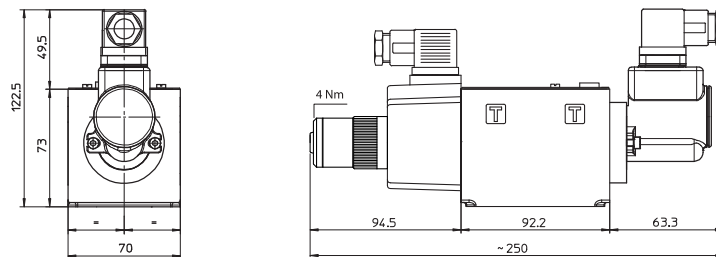

Mass: kg 3,7

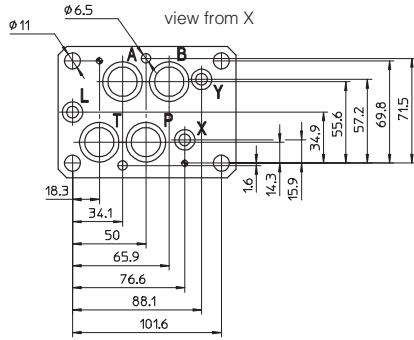

DPH*-2*
ISO 4401: 2005
Mounting surface: 4401-07-07-0-05

Fastening bolts:
 4 socket head screws M10x50 class 12.9
 Tightening torque = 70 Nm
 2 socket head screws M6x45 class 12.9
 Tightening torque = 15 Nm
 Diameter of ports A, B, P, T: $\varnothing = 20$ mm;
 Diameter of ports X, Y: $\varnothing = 7$ mm;
 Seals: 4 OR 130, 2 OR 2043

- P** = PRESSURE PORT
- A, B** = USE PORT
- T** = TANK PORT
- X** = EXTERNAL OIL PILOT PORT
- Y** = DRAIN PORT

DPH*-2/FC

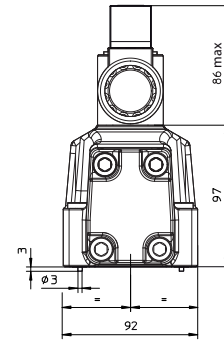
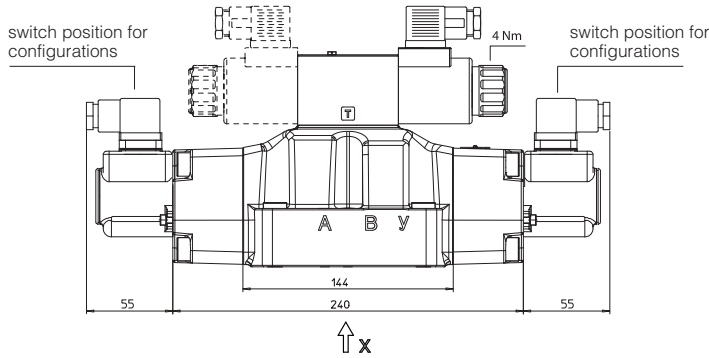

Note: for configurations 71 and 75 the switch position is on both sides of the valve

Mass:
 kg 9,6 (one solenoid)
 kg 10,3 (two solenoids)

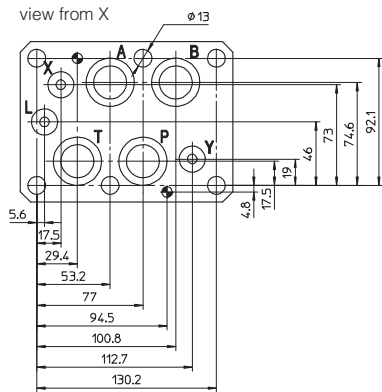

DPH*-3*
ISO 4401: 2005
Mounting surface: 4401-08-08-0-05

Fastening bolts:
 6 socket head screws M12x50 class 12.9
 Tightening torque = 125 Nm
 Diameter of ports A, B, P, T: $\varnothing = 24$ mm;
 Diameter of ports X, Y: $\varnothing = 7$ mm;
 Diameter of port L: $\varnothing = 5$ mm;
 Seals: 4 OR 4112, 3 OR 3056

- P** = PRESSURE PORT
 - A, B** = USE PORT
 - T** = TANK PORT
 - X** = EXTERNAL OIL PILOT PORT
 - Y** = DRAIN PORT
 - L** = NOT USED
- For the max pressures on ports, see section 4

DPH*-3/FC

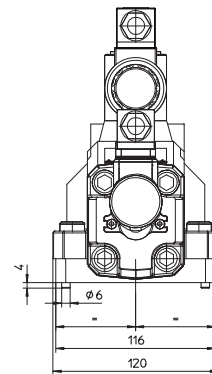
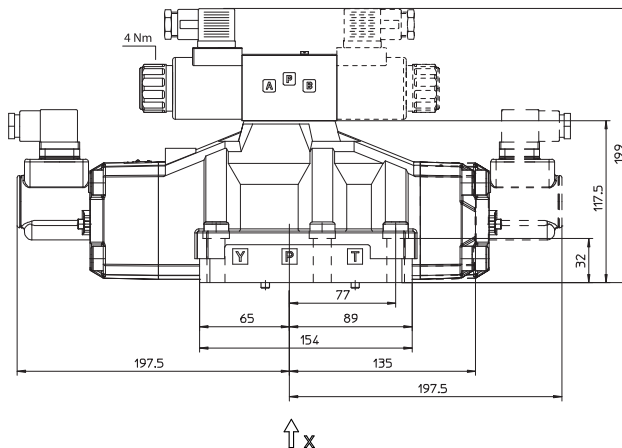

Note: for configurations 71 and 75 the switch position is on both sides of the valve

Mass:
 kg 14,6 (one solenoid)
 kg 15,3 (two solenoids)